

---

# RHM

## Dock Leveler

### Owners Manual

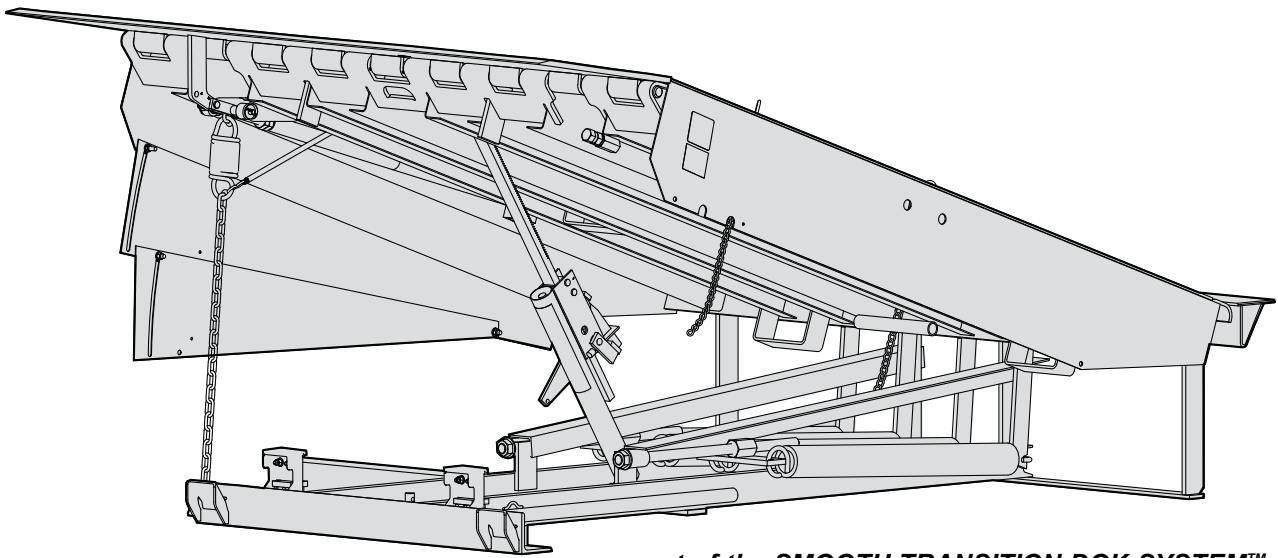

*part of the SMOOTH TRANSITION DOK SYSTEM™*



**This Manual Covers Dock Levelers Built After Serial Number:  
04ID410001M and up**

# NOTES

# TABLE OF CONTENTS

NOTICE TO USER .....	3
SAFETY WARNINGS .....	4
OWNER RESPONSIBILITY .....	7
OPERATION INSTRUCTIONS .....	8
MAINTENANCE PROCEDURES .....	10
LEVELER ADJUSTMENTS / TROUBLESHOOTING .....	11
REPLACEMENT PARTS .....	14
STANDARD WARRANTY .....	BACK COVER

## PRODUCT SPECIFIC WARRANTY

RITE-HITE® warrants the RHM Dock Leveler for five-years parts and one-year labor from date of shipment in accordance with Rite-Hite's Standard Warranty Policy.

## NOTICE TO USER

Your local RITE-HITE® representative provides a Planned Maintenance Program (P.M.P.) which can be fitted to your specific operation. Call your local representative or the RITE-HITE® Corporation at 414-355-2600.

The RITE-HITE® products in this manual are covered by one or more of the following U.S. patents: 5,271,183; 5,323,503; 5,546,623; 5,553,987; 5,582,498; 5,664,930; 5,702,223; 5,762,459 (RE: 37,570); 5,882,167; 6,065,172; 6,070,283; 6,085,375; 6,092,970; 6,106,212; 6,116,839; 6,190,109; 6,220,809; 6,276,016; 6,311,352; 6,318,947; 6,322,310; 6,360,394; 6,368,043; 6,431,819; 6,488,464; 6,499,169; 6,502,268; 6,505,713; 6,524,053; 6,634,049; 6,654,976; 6,726,432; 6,773,221; 6,832,403; 6,880,301; 6,892,411; 7,032,267; 7,062,814; 7,134,159; 7,213,285; 7,216,391; 7,363,670; 7,380,305; 7,503,089; 7,553,431; 7,584,517; 7,681,271; 7,823,239; 7,841,823; 7,877,831 and pending U.S and foreign patent applications. RITE-HITE®, LEVEL-RITE®, THINMAN™, SAFE-T-LIP®, HYDRACHEK®, WHEEL-LOK™, DOK-LOK®, DUAL-DOK®, SAFE-T-STRUT™, DOK-COMMANDER®, JUMBO™, HYDRA-RITE™, SAFE-T-GATE®, and SMOOTH TRANSITION DOK SYSTEM™, are trademarks of RITE-HITE® Corporation.

## SAFETY WARNINGS

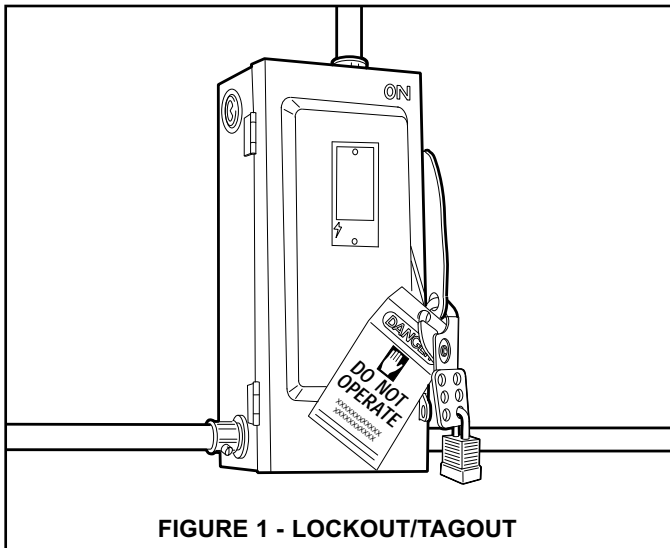

### **WARNING**

When working with electrical or electronic controls, make sure that the power source has been locked out and tagged out according to OSHA regulations and approved local electrical codes.

## LOCKOUT/TAGOUT PROCEDURES

The Occupational Safety and Health Administration (OSHA) requires, in addition to posting safety warnings and barricading the work area (including, but not limited to, trucking office and loading docks), that the power supply has been locked in the OFF position or disconnected. It is mandatory that an approved lockout device is utilized. An example of a lockout device is illustrated. The proper lockout procedure requires that the person responsible for the repairs is the only person who has the ability to remove the lockout device.

In addition to the lockout device, it is also a requirement to tag the power control in a manner that will clearly note that repairs are under way and state who is responsible for the lockout condition. Tagout devices have to be constructed and printed so that exposure to weather conditions, or wet and damp locations, will not cause the tag to deteriorate or become unreadable.

RITE-HITE® does not recommend any particular lockout device, but recommends the utilization of an OSHA approved device (refer to OSHA regulation 1910.147). RITE-HITE® also recommends the review and implementation of an entire safety program for the Control of Hazardous Energy (Lockout/Tagout). These regulations are available through OSHA publication 3120.

### **DANGER**

This is the highest level statement. Failure to follow the listed instructions will most likely result in severe injury or death.

### **CAUTION**

The statements used with this level of warning deal with a safe operating procedure. If the procedure is ignored the possibility of personal injury may exist.

### **WARNING**

This is a statement of serious hazard. Failure to follow the listed instructions could place the individual at risk of serious injury or death.

### **IMPORTANT**

**IMPORTANT** is used to draw attention to a procedure that needs to be followed to prevent machine damage.

## OTHER IMPORTANT OPERATIONAL SAFETY WARNINGS

### **DANGER**

Never be under the dock leveler platform or lip without:

- Installing the Safe-T-Strut™ or other supporting device.
- If lip needs to be extended, follow procedures shown under Safety Devices on the following page.
- Turning off power to the control box.
- Locking out and tagging out the main power source, as shown under Safety Warnings on preceding page.

### **WARNING**

Always barricade the dock leveler at ground level and dock level from any form of traffic when maintenance is required.

### **CAUTION**

Inspect the dock leveler monthly to ensure that there are no broken or worn parts which could cause injury to personnel or damage to the equipment.

### **WARNING**

- Before starting installation or maintenance, check and follow the safety procedures of the facility where the dock leveler is being installed.
- Never enter a truck/trailer until its brakes are set, air has been dumped from air ride suspension (if applicable), and you have visually inspected to be sure truck/trailer is securely held in place by a vehicle restraint or wheel chock per OSHA regulations.
- Never operate the leveler with you, anyone, or anything on, or in front of the leveler, or without a truck/trailer parked in position, or from on the truck/trailer bed.
- DO NOT operate with anyone under platform or in front of the lip.
- When leveler is not in use, always store it so that it is supported by the lip supports and that it is level with the surrounding dock floor.
- If a malfunction does occur, always call your authorized RITE-HITE® service representative immediately.

## SAFETY DEVICES

### DANGER

Never be under the dock leveler platform or lip without:

- Installing the Safe-T-Strut™. See below right. This can be done with the assistance of another person by:
  - Raise leveler until platform reaches its highest position and lip extends. Continue to maintain this position.
  - Then have assistant insert the smaller end of the Safe-T-Strut™ through the hole in the middle of the leveler lip and place the strut's wider open end over the base located on the leveler's front frame. Align the holes on the base and the Safe-T-Strut™ so that the leveler may be secured with the retaining pin and safety clip.
  - Release the pushbutton on powered levelers allowing the Safe-T-Strut™ to rest on the underside of the lip.
- Lockout/Tagout power supply.
  - Turn off the power to the control box.
  - Lockout/tagout the main power source, as shown under Safety Warnings on the inside front cover of this manual.
  - Always barricade the leveler at dock level and drive level to prevent any unauthorized use of the leveler.

Remove the Safe-T-Strut™.

- For Safe-T-Strut™ removal, have an assistant raise the leveler to its highest position with lip fully extended. Release the safety clip and remove retaining pin. Lift strut off base, and remove from lip. Return the Safe-T-Strut™ to the proper storage position.
- If you are unable to install the Maintenance Support properly, contact your authorized RITE-HITE® Service Representative or RITE-HITE® Customer Service at 1-414-355-2600.

### CAUTION

- Post warnings and barricades at dock level and at drive level to indicate that work is being done around and under the leveler platform.
- Lockout/Tagout power to the leveler and post warnings when work is being performed on the leveler.

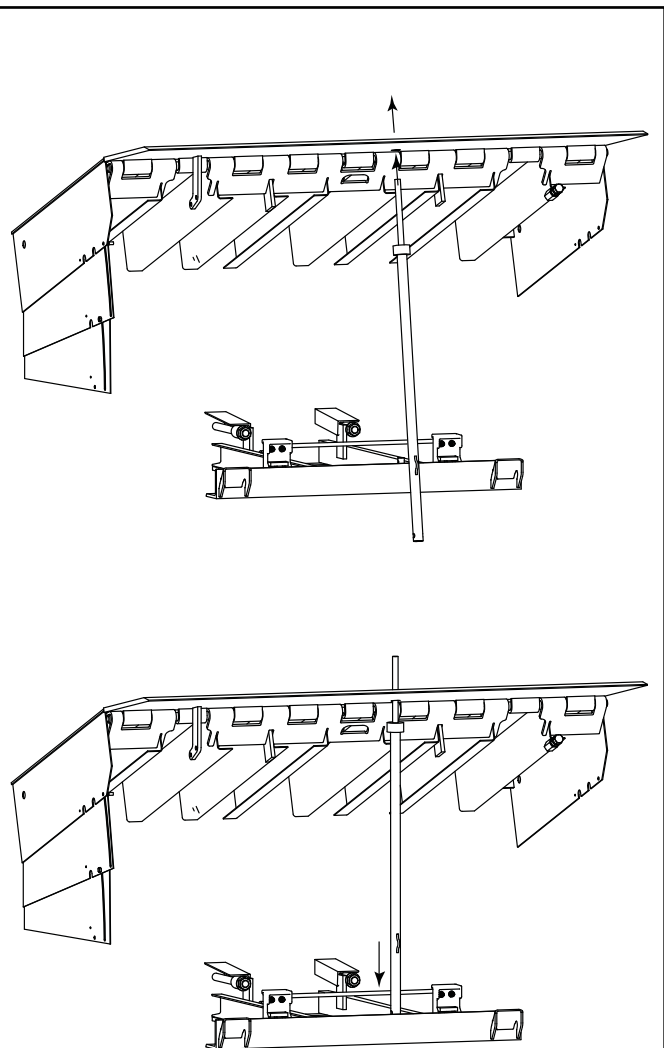

FIGURE 2 - INSTALL SAFE-T-STRUT™ SUPPORT

## OWNER RESPONSIBILITY

1. The owner should recognize the inherent danger of the interface between dock and transport vehicle. The owner should, therefore, train and instruct operators in the safe use of dock equipment in accordance with the information provided below. The manufacturer shall publish, provide to the initial purchaser, and make the following information readily available to owners:
  - Installation instructions
  - Recommended initial and periodic inspections procedures
  - Maintenance procedures
  - Operating instructions
  - Descriptions or specifications for replaceable or repairable parts
  - Tables identifying the grade (slope) for all variations of length or configuration of the dock equipment, and
  - Information identifying the maximum uncontrolled drop encountered upon sudden removal of support while within the working range of the equipment.

It shall be the responsibility of the owner to verify that the material listed in this section has been received and that it is made available for the instruction and training of personnel entrusted with the use or maintenance of the dock equipment.
2. When a transport vehicle is parked at a loading dock, it is important that the vehicle is relatively perpendicular to the dock face and in close contact with at least one of the dock bumpers.
3. Nameplates, cautions, instructions, and posted warnings shall not be obscured from the view of operating or maintenance personnel for whom such warnings are intended.
4. Manufacturer's recommended periodic maintenance and inspection procedures in effect at date of shipment shall be followed, and written records of the performance of these procedures should be kept.
5. As with any piece of machinery, dock equipment requires routine maintenance, lubrication, and adjustments. Your local RITE-HITE® representative offers owners the option of a Planned Maintenance Program (P.M.P.). As part of this service, your local RITE-HITE® representative will do all routine maintenance, lubrication, and adjustments.
6. Dock equipment that is structurally damaged shall be removed from service, inspected by a manufacturer's authorized representative, and repaired as needed before being placed back in service.
7. The manufacturer shall make available replacement nameplates, caution/instruction labels, and operating/maintenance manuals upon request of the owner. The owner shall see that all nameplates, caution/instruction markings or labels are in place and legible, and that the appropriate operating/maintenance manuals are provided to users.
8. Modifications or alterations of dock equipment shall be made only with written permission of the original manufacturer. These changes shall also satisfy all safety recommendations of the original equipment manufacturer for the particular application of the dock equipment.
9. In order to be entitled to the benefits of the standard product warranty, the dock equipment must have been properly installed, maintained and operated within its rated capacities and/or specific design parameters, and not otherwise abused.
10. It is recommended that trailers equipped with air ride suspensions should remove the air from the suspension to minimize trailer bed drop, prior to loading or unloading.
11. When industrial trucks are driven on and off transport vehicles during the loading and unloading operation, the brakes on the transport vehicle shall be applied and wheel chocks or a positive restraining device shall be engaged.
12. In selecting dock equipment, it is important to consider not only present requirements but also future plans or adverse environments.

# OPERATION INSTRUCTIONS

## NORMAL OPERATION

1. Activate the leveler by pulling and holding the ramp control release chain until the platform is at the highest position and the lip is fully extended. See figure 3.

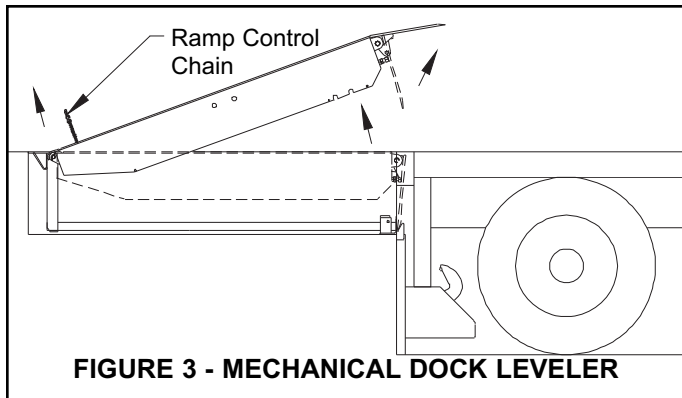

2. Walk on platform to the front edge (DO NOT walk on lip). The platform will lower until the lip contacts the truck/trailer bed. Be sure the lip is in full contact with the truck/trailer bed. See figure 4.

**NOTE:** Be sure the lip is in full contact with the truck/trailer bed before loading or unloading truck/trailer.

3. See *Storing Leveler*.

**NOTE:** If the truck/trailer departs, the lip will fall to the pendant position inside the dock bumpers. See *Storing Leveler*.

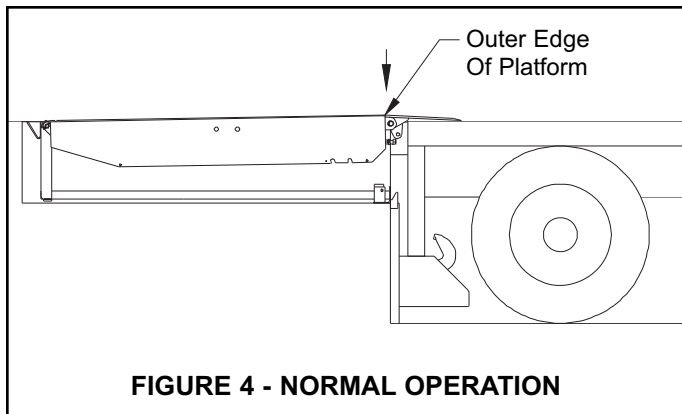

## BELOW DOCK LOADING OPERATION

1. To service truck/trailers with beds lower than the dock level, activate the leveler by pulling and holding the ramp control release chain until platform is at the highest position and the lip is fully extended. Release the chain. See figure 3.
2. Walk on platform to the front edge (DO NOT walk on lip). While the platform is lowering pull and hold the safety leg release chain until the lip contacts the truck/trailer bed. Be sure the lip is in full contact with the truck/trailer bed. See figure 5.
3. When loading/unloading is complete, continue with normal operation or return the leveler to stored position. See *Storing Leveler*.

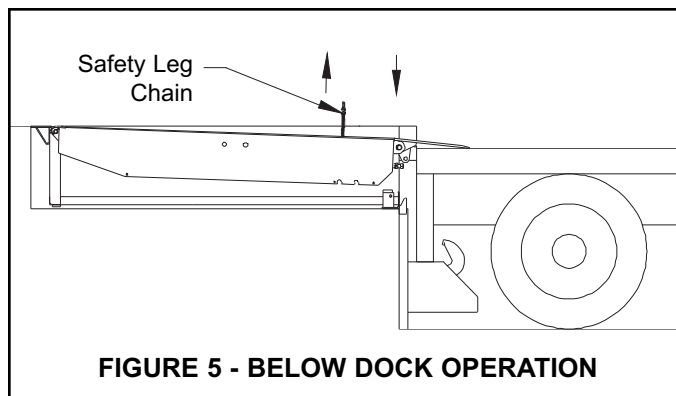

## OPERATION INSTRUCTIONS CONT.

### BELOW DOCK END LOADING OPERATION

1. To service truck/trailers with end loads, activate the leveler by jogging the ramp control release chain (short, quick pulls of chain) until the platform has risen 12 to 14 inches and the lip is pendant. Release the ramp control release chain.
2. Walk on platform to the front edge (DO NOT walk on lip). While the platform is lowering pull and hold the safety leg chain. Walk the leveler down until the platform is in the fully below dock position with the lip positioned between the face of the loading dock and the truck/trailer bed. Release safety leg chain. See figure 6.

**NOTE:** End loads at dock level and above can be handled with the leveler in its stored position.

3. When loading/unloading is complete, continue with normal operation or return the leveler to stored position. See *Storing Leveler*.

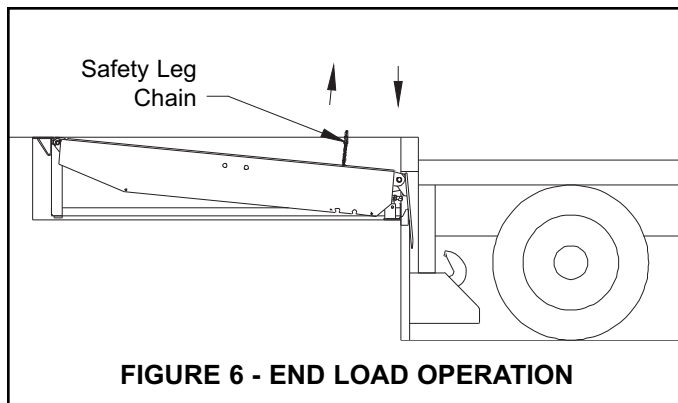

### STORING LEVELER

1. To store the leveler if platform is lower than dock level, jog the ramp control release chain until platform is 2 to 3 inches above dock level and lip is fully pendant, then walk on platform to lower to dock level with lip resting in the lip supports.

**NOTE:** If platform is higher than dock level and lip is fully pendant, walk on the platform to lower to dock level with lip resting in the lip supports. See figure 7.

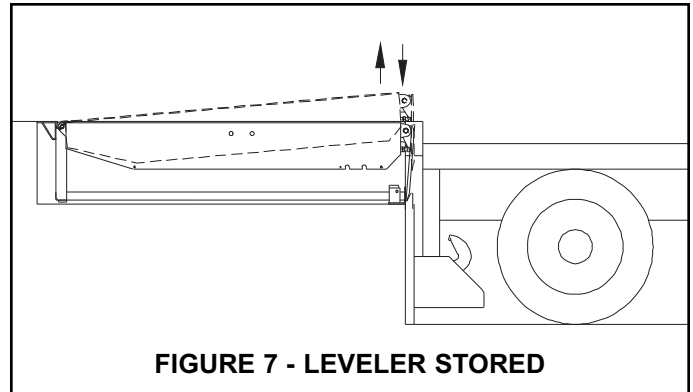

## MAINTENANCE PROCEDURES

### **WARNING**

Read and obey these instructions to prevent personal injury.

- **Post safety warnings and barricade work area, at dock level and at ground level, to prevent unauthorized use of the dock position before maintenance has been completed.**
- **Make sure to install the maintenance support strut before proceeding with any repair work.**

### SUGGESTED LEVELER MAINTENANCE

**NOTE:** Follow maintenance procedures below as outlined. Include the specific steps for your leveler model.

**NOTE:** Your local RITE-HITE® representative provides a Planned Maintenance Program (P.M.P.) which can be fitted to your specific operation. Call your local representative.

#### Daily

1. Remove debris on and around leveler. Be sure the hinge section of the lip and the platform is clean.
2. Check unit for proper operation.

#### 90 Days

1. Perform all Daily Maintenance.
2. Clean pit.
3. Inspect lip out mechanism (pins, lip crank, links, chains and shackles). Replace if worn.
4. Lubricate the leveler with the proper lubricants. See figure 8.
5. Inspect all weather seals (if installed) and replace if worn or damaged.
6. Inspect dock bumpers. Four inches (4") of bumper protection is required. Worn, torn, loose or missing bumpers must be replaced.
7. Check conditions of concrete, angles and welds. Repair or replace if necessary.
8. Inspect structure, hinge pins, clevis pins and cotter pins for abnormal wear.

#### 360 Days

1. Perform Daily and 90-Day Maintenance.

# LUBRICATION CHART

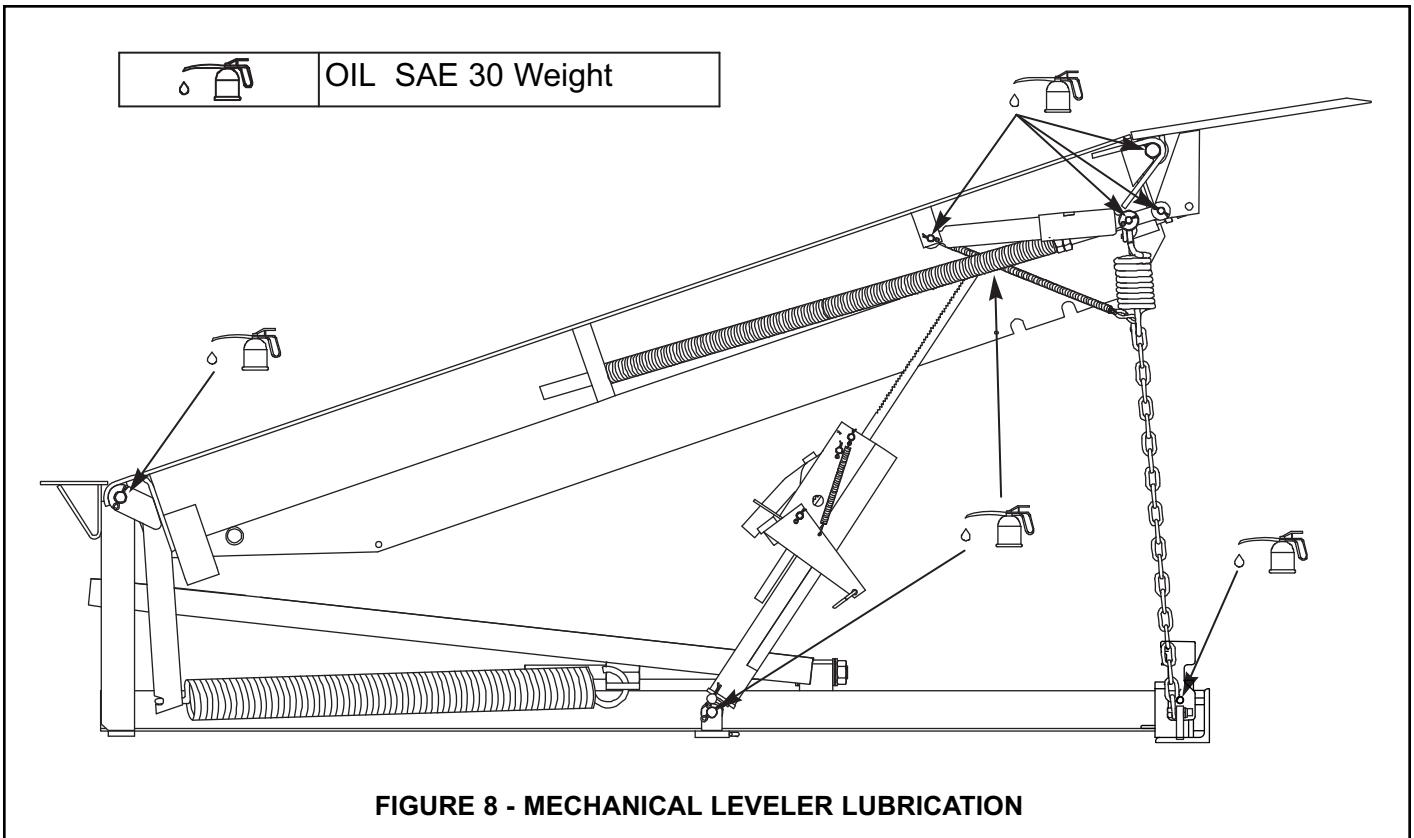

**⚠ DANGER**

- DO NOT operate leveler with anyone standing on or in front of the lip.
- NEVER go under the leveler platform or lip without installing the Maintenance Support.

**LIP STOP BOLT:**

The lip stop bolt adjusts the position of the lip when the leveler is stored to allow the lip to be centered on lip supports when stored.

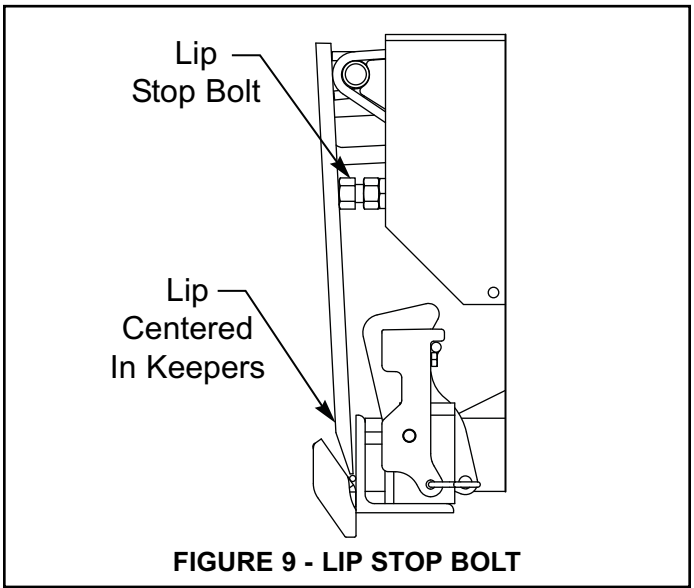

## LEVELER ADJUSTMENTS CONT.

### WARNING

Make sure to position the maintenance support when making the lip assist spring adjustment.

### DANGER

NEVER REMOVE adjustment nuts from main spring adjustment rod. Serious injury or death will occur.

### WARNING

- Make sure to insert the Safe-T-Strut™ when making the main extension spring adjustment.
- Refer to operating instructions - follow all CAUTIONS and WARNINGS prior to activating your dock leveler.

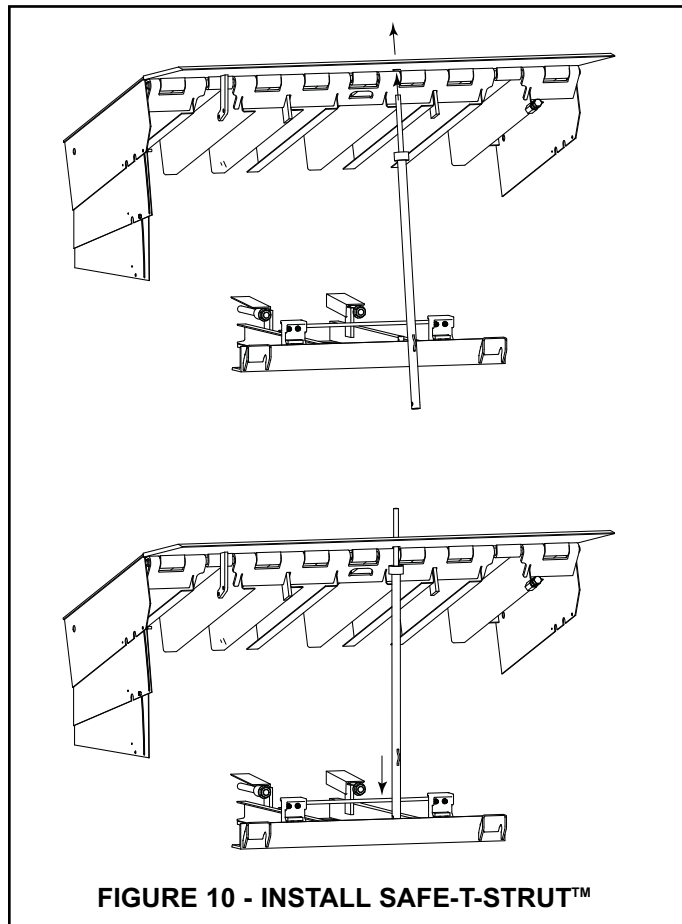

FIGURE 10 - INSTALL SAFE-T-STRUT™

### LIP ASSIST SPRING ADJUSTMENT

1. Proper adjustment of the lip assist spring is defined as “the condition of maximum spring compression that permits the lip to fall of its own weight to the fully pendant position.”
2. To adjust the lip assist spring, release the lock nut and advance the adjustment nut clockwise to produce maximum compression on the spring while still allowing the lip to fall.
3. Back off the adjustment nut until the lip, when dropped from the fully extended position, barely overcomes the spring tension and falls to the pendant position. Tighten the lock nut to secure the adjustment.

### MAIN LIFT SPRING ADJUSTMENT

**GOAL** - To MINIMIZE the spring force (and ultimately the walkdown) while still reliably latching the lip and raising from below dock.

**Note:** Adjustments should be made in small increments equally to each adjustment nut. (i.e. 1/2 turn at a time on both adjustment nuts)

With the leveler positioned at dock height or in the stored position, raise the platform and allow the lip to extend and latch. If the lip does NOT latch:

- Due to a lack of spring energy - Increase the spring tension on the lift springs by turning each of the nuts on the spring pull bar weldment(s) clockwise in equal, full turn increments.
  - Due to the platform raising violently - Decrease the spring tension on the lift springs by turning each of the nuts on the spring pull bar weldment(s) counter-clockwise in equal, full turn increments.
- Verify that the platform will raise from the fully below dock position Do NOT allow the lip to extend! If the platform does NOT raise:
- Increase the spring tension on the lift springs by turning each of the nuts on the spring pull bar weldment(s) clockwise in equal, full turn increments.

## LEVELER TROUBLESHOOTING

Problem	Probable Cause	Solution
1. Lip will not extend	<ul style="list-style-type: none"> <li>a. Snubber chain assembly is disconnected or broken.</li> <li>b. Lip assist spring out of adjustment or broken.</li> <li>c. Platform did not raise fully.</li> <li>d. Debris</li> </ul>	<ul style="list-style-type: none"> <li>a. Replace or reconnect chain assembly.</li> <li>b. Adjust lip assist spring. See adjustment procedures or replace.</li> <li>c. Adjust main springs. See adjustment procedures or replace damaged springs.</li> <li>d. See maintenance procedures.</li> </ul>
2. Lip is partially extended.	<ul style="list-style-type: none"> <li>a. Platform did not raise fully.</li> <li>b. Lip assist spring out of adjustment.</li> <li>c. Debris</li> </ul>	<ul style="list-style-type: none"> <li>a. Adjust main springs. See adjustment procedures or replace damaged springs. Consult local representative or Rite-Hite.</li> <li>b. Adjust lip assist spring. See adjustment procedures.</li> <li>c. See maintenance procedures.</li> </ul>
3. Lip remains fully extended (after serving trailer).	<ul style="list-style-type: none"> <li>a. Lip assist spring out of adjustment.</li> <li>b. Lip assist rod binding.</li> <li>c. Debris</li> </ul>	<ul style="list-style-type: none"> <li>a. Reduce lip assist spring. See adjustment procedures.</li> <li>b. Check for obstruction.</li> <li>c. See maintenance procedures.</li> </ul>
4. Platform does not raise when ramp control release chain (rear release ring) is pulled and held.	<ul style="list-style-type: none"> <li>a. Broken or unhooked ramp control release chain.</li> <li>b. Debris</li> <li>c. Main springs broken or out of adjustment.</li> </ul>	<ul style="list-style-type: none"> <li>a. Repair or replace. Consult Local representative or Rite-Hite.</li> <li>b. See maintenance procedures.</li> <li>c. Adjust main springs. See adjustment procedures or replace damaged springs. Consult local representative or Rite-Hite.</li> </ul>
5. Leveler is hard to walk down.	<ul style="list-style-type: none"> <li>a. Excessive main spring tension.</li> <li>b. Pit wall interference.</li> </ul>	<ul style="list-style-type: none"> <li>a. Adjust main springs. See adjustment procedures.</li> <li>b. Check for equal clearance, remove debris. See maintenance procedures.</li> </ul>
6. Ramp control release chain is hard to pull. (rear release chain)	<ul style="list-style-type: none"> <li>a. Bent ratchet bar.</li> <li>b. Release crank binding.</li> </ul>	<ul style="list-style-type: none"> <li>a. Repair or Replace if necessary.</li> <li>b. Check for proper chain routing, remove debris, lubricate. See maintenance procedures.</li> </ul>
7. Leveler will not go below dock.	<ul style="list-style-type: none"> <li>a. Endload leg assembly will not retract.</li> <li>b. Pit wall interference.</li> </ul>	<ul style="list-style-type: none"> <li>a. Repair or replace damaged linkage.</li> <li>b. See Item #5.</li> </ul>

# RHM REPLACEMENT PARTS

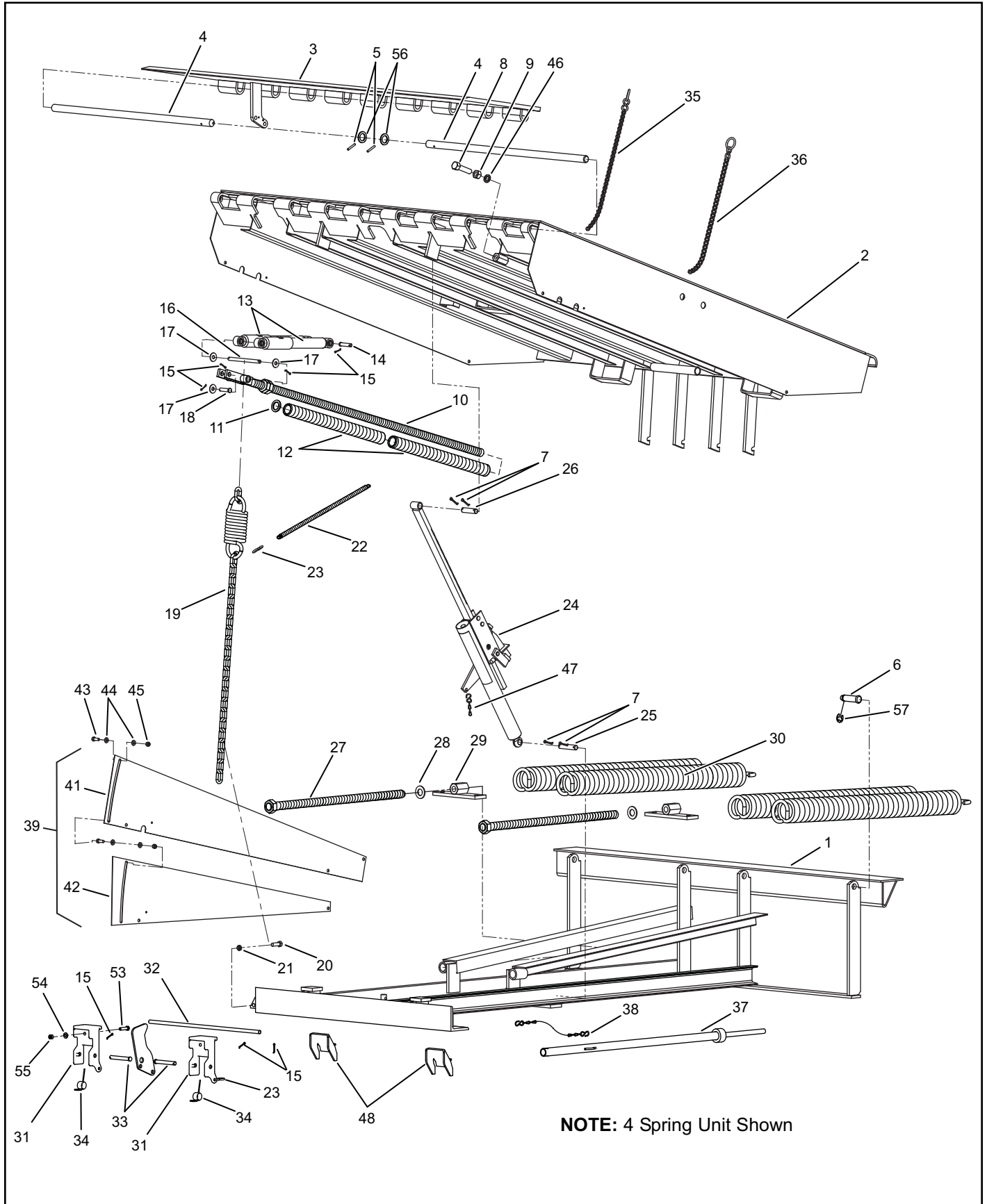

NOTE: 4 Spring Unit Shown

**RHM REPLACEMENT PARTS LIST**

Item	Qty.	Description	Leveler Length and Capacity			
			6' Long	8' Long	8' Long	10' Long
			(B - F Cap.)	(B - D Cap.)	(F Cap.)	(B - F Cap.)
1	1	Frame Weldment	362.xxx	362.xxx	362.xxx	362.xxx
2	1	Platform Weldment	533.xxx	533.xxx	533.xxx	533.xxx
3	1	Lip Weldment	547.xxx	547.xxx	547.xxx	547.xxx
4	2	Pin Lip Hinge 6' Wide	562.101	562.101	562.101	562.101
	2	Pin Lip Hinge 6.5' Wide	562.102	562.102	562.102	562.102
5	2	Pin Lip Hinge 7' Wide	562.100	562.100	562.100	562.100
	2	Pin Lip Hinge 6' Wide (Stainless Steel)	490.101	490.101	490.101	490.101
	2	Pin Lip Hinge 6.5' Wide (Stainless Steel)	490.102	490.102	490.102	490.102
	2	Pin Lip Hinge 7' Wide (Stainless Steel)	490.103	490.103	490.103	490.103
	2	Pin Tension .25Dia. x 1.75L	123960	123960	123960	123960
6	4	Clevis Pin, Headed .875 x 3.25L Groove ZP	129307	129307	129307	129307
	4	Clevis Pin, Headed .875 x 3.25L Gr (Stainless Steel)	129309	129309	129309	129309
7	5	Cotter Pin, .188Dia. x 1.50L ZP	51907	51907	51907	51907
8	1	Bolt, Hex .75-10UNC x 3.00L ZP	51186	51186	51186	51186
9	1	Nut, Hex .75-10 HEX GR5 ZP	51517	51517	51517	51517
10	1	Lip Assist Rod, 1Dia. 48L	01551	01551	01551	01551
11	1	Machine Bushing, 1.50OD x 1.00ID x .134THK ZP	51730	51730	51730	51730
12	2	Lip Assist Compression Spring	See Chart - Page 18			
13	2	Hydrachek, 1" Bore	See Chart - Page 18			
14	2	Clevis Pin, Headed .5Dia. x 2.313L 1Hole ZP	52418	52418	52418	52418
15	7	Cotter Pin, .125Dia. x 1	51901	51901	51901	51901
16	1	Clevis Pin, .5Dia. x 7L 2Hole	52637	52637	52637	52637
17	3	Flat Washer, .5Dia. ZP	51705	51705	51705	51705
18	1	Clevis Pin, Headed .5Dia. x 2L 1Hole ZP	52409	52409	52409	52409
19	1	Snubbing Chain Assy.	511.100	511.100	511.100	511.100
20	1	Bolt .500-13 x 1.5 Cap HEX GR5 ZP	51674	51674	51674	51674
21	1	Nut .500-13 Nylock Jam ZP	112965	112965	112965	112965
22	1	Extension Spring, .5OD .39ID 5L 2.07Lb/Inch	52047	52047	52047	52047
23	3	S-Hook, .219 Wire	51102	51102	51102	51102
24	1	Ramp Control Assy	00505	00505	00505	00505
25	1	Clevis Pin, .75Dia. x 3.625L ZP	52604	52604	52604	52604
26	1	Clevis Pin, .75Dia. x 3L ZP	52618	52618	52618	52618
27	2	Bolt, Hex 1-8UNC x 24L G2	116869	116869	116869	116869
28	2	Flat Washer, 1.00 SAE ZP	51721	51721	51721	51721
29	2	Spring Pull Bar, 2Hole Thrd (Units with 4 Springs)	116835	116835	-	-
30	~	Spring Pull Bar, 3Hole Thrd (Units with 6 Springs)	-	-	116836	116836
		Main Ramp Lift Extension Spring	Contact Rite-Hite			
31	2	Safety Leg 2.56 x 3.5 x 5.88L (Casting)	129077	129077	129077	129077
32	1	Round .5Dia. 28.25L HR M1020	493.100	493.100	493.100	493.100
33	2	Headed Clevis Pin, .5Dia. x 4L 1Hole ZP	117066	117066	117066	117066
34	2	Torsion Spring, 180Deg. 0.625ID (.105Dia)	120461	120461	120461	120461
35	1	Chain Assy. Lnyd Twist #1/0 ZP	510.100	510.102	510.102	510.109
36	1	Chain Assy. Lnyd Twist #1/0 ZP	510.101	510.107	510.102	510.109
37	1	Safe-T-Strut 47.75L	118021	118021	118021	118021
39	1	Safe-T-Strut Chain Assy.	117678	117678	117678	117678

# RHM REPLACEMENT PARTS

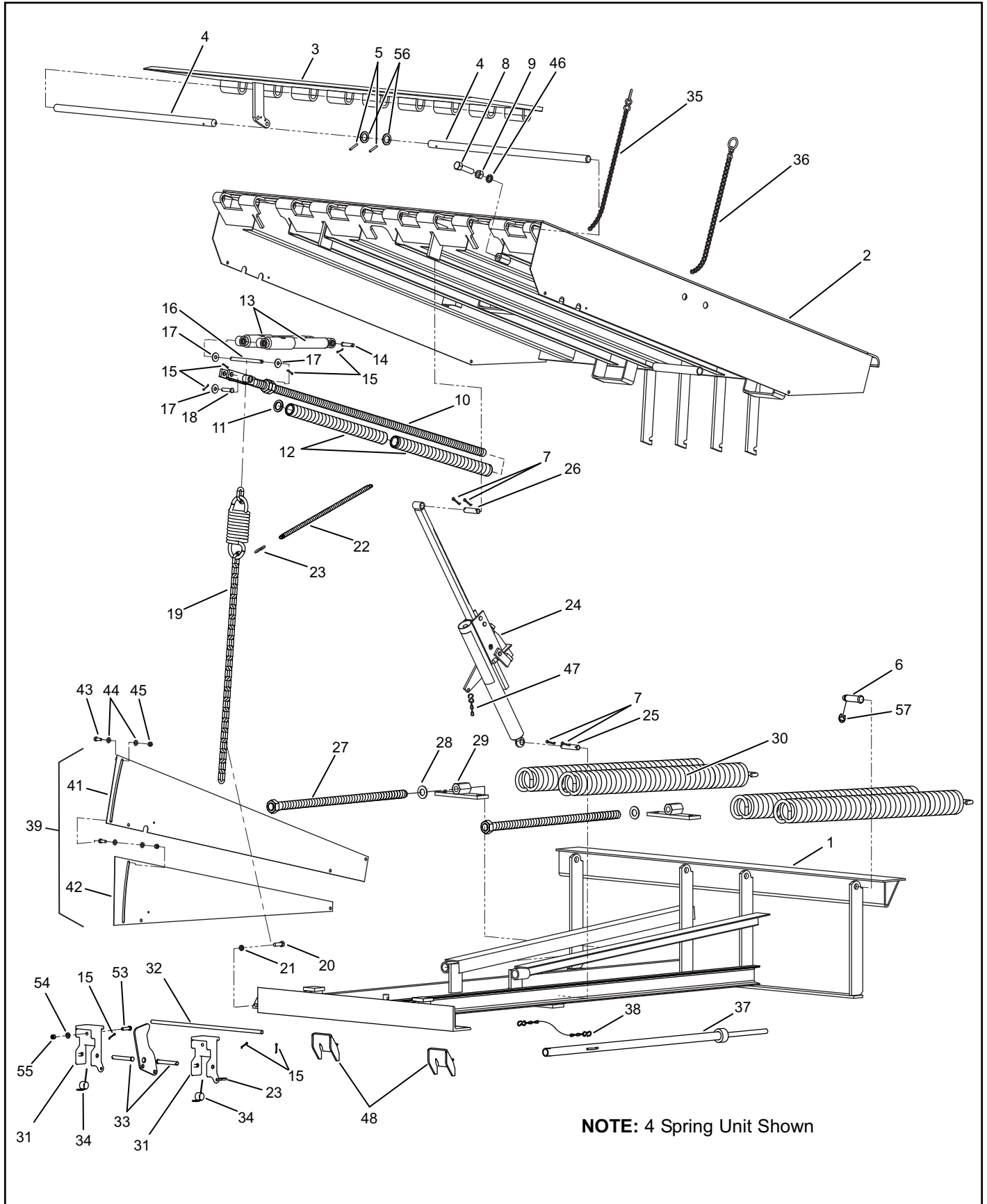

**NOTE:** 4 Spring Unit Shown

**RHM REPLACEMENT PARTS LIST**

Item	Qty.	Description	Leveler Length and Capacity			
			6' Long	8' Long	8' Long	10' Long
			(B - F Cap.)	(B - D Cap.)	(F Cap.)	(B - F Cap.)
39	1	Toeguard Assy. Full Range LH (2 Fan)	417.102	417.103	417.103	417.104
40	1	Toeguard Assy. Full Range RH (2 Fan) (Not Shown)	418.102	418.103	418.103	418.104
41	1	Toeguard Fan 14Ga. x 11 4Hole LH	411.100	411.101	411.101	564.100
	1	Toeguard Fan 14Ga. x 11 4Hole RH (Not Shown)	411.100	411.101	411.101	564.100
42	1	Toeguard Fan 14Ga. x 11 3Hole LH	416.100	416.101	416.101	565.109
	1	Toeguard Fan 14Ga. x 11 3Hole RH (Not Shown)	416.100	416.101	416.101	566.109
43	8	Bolt, Hex .375-16UNC x 1L G5 ZP	51600	51600	51600	51600
44	16	Washer Flat .38 ZP	51700	51700	51700	51700
45	8	Nylock Nut, .38-16UNC ZP	51501	51501	51501	51501
46	1	Washer .758Dia. Split LK Heavy ZP	51814	51814	51814	51814
47	1	Ramp Control Relief Chain (See Note Below)	55627	55627	55627	55627
	1	Ramp Control Relief Chain (See Note Below)	125772	125772	125772	125772
48	2	Lip Keeper Weldment Formed	129201	129201	129201	129201
49	2	Weatherseal Insert PT2-1 (Not Shown)	513.105	513.104	513.104	513.106
	2	Weatherseal Insert NB1-1 (Not Shown)	514.105	514.104	514.104	514.106
50	1	Operational Sign (Not Shown)	128111	128111	128111	128111
51	1	Decal Sheet Manufacturing (Not Shown)	128116	128116	128116	128116
52	1	Decal Sheet Field (Not Shown)	128121	128121	128121	128121
53	4	Bolt .375-16 x 1.500 CAP HEX Grade-8ZP	68207	68207	68207	68207
54	4	Washer Flat .38 ZP	51700	51700	51700	51700
55	4	Nut .375-16 Nylock ZP	123810	123810	123810	123810
56	2	Washer Flat 1.125 ID 1.750 OD .1406Thk ZP	139809	139809	139809	139809
57	4	Ring, Ext. Retaining, .875OD	129308	129308	129308	129308

**NOTE:** Use part number 125772 on units produced **after** July 1st 2007.

## LIP ASSIST SPRING AND HYDRACHEK CHARTS

Lip Assist Spring Chart			
Leveler Length	Nominal Width (ft)	Capacity	Lip Spring
16-18	6W	C-D	52011
16	6.5, 7W	C-D	52011
16	6, 6.5, 7W	F	52011
20	6, 6.5, 7W	C-D	52014
18	6.5, 7W	C-D	52014
18	6, 6.5, 7W	F	52014
20	6, 6.5, 7W	F	52041

Hydrachek Chart				
Lip Thickness (in)	Lip Length (in)	Lip Width (in)	Hydrachek Part No.	Quantity
1/2	16-20	72-83	51147-1	2
5/8	16-20	72-83	51147-1	1
			51147-2	1
11/16	16	72-83	51147-1	1
			51147-2	1
11/16	18-20	72-83	51147-2	2

**NOTES**

## **RITE-HITE® STANDARD WARRANTY**

RITE-HITE® warrants that its products will be free from defects in design, materials, and workmanship for a period of 365 days from the date of shipment. All claims for breach of this warranty must be made within 30 days after the defect is or can, with reasonable care, be detected and in no event no more than 30 days after the warranty has expired. In order to be entitled to the benefits of this warranty, the products must have been properly installed, maintained, and operated within their rated capacities and/or specified design parameters, and not otherwise abused. Periodic lubrication and adjustment is the sole responsibility of the owner. This warranty is RITE-HITE's® exclusive warranty. RITE-HITE® EXPRESSLY DISCLAIMS ALL IMPLIED WARRANTIES, INCLUDING THE IMPLIED WARRANTIES OF MERCHANTABILITY AND FITNESS. Non-standard warranties, if any, must be specified by RITE-HITE® in writing.

In the event of any defects covered by this warranty, RITE-HITE® will remedy such defects by repairing or replacing any defective equipment or parts, bearing all the costs for parts, labor, and transportation. This shall be the exclusive remedy for all claims whether based on contract, negligence, or strict liability.

## **LIMITATION OF LIABILITY**

RITE-HITE® SHALL NOT IN ANY EVENT BE LIABLE FOR ANY LOSS OF USE OF ANY EQUIPMENT OR INCIDENTAL OR CONSEQUENTIAL DAMAGES OF ANY KIND, WHETHER FOR BREACH OF WARRANTY, NEGLIGENCE, OR STRICT LIABILITY.



### **Global Sales & Service Office:**

**RITE-HITE®  
8900 N. Arbon Drive  
P.O. Box 245020  
Milwaukee, Wisconsin 53224**

**Phone: 414-355-2600  
1-800-456-0600  
[www.ritehite.com](http://www.ritehite.com)**

**Representatives in all Major Cities**