

LRL

Elevating Dock Lift Installation Manual

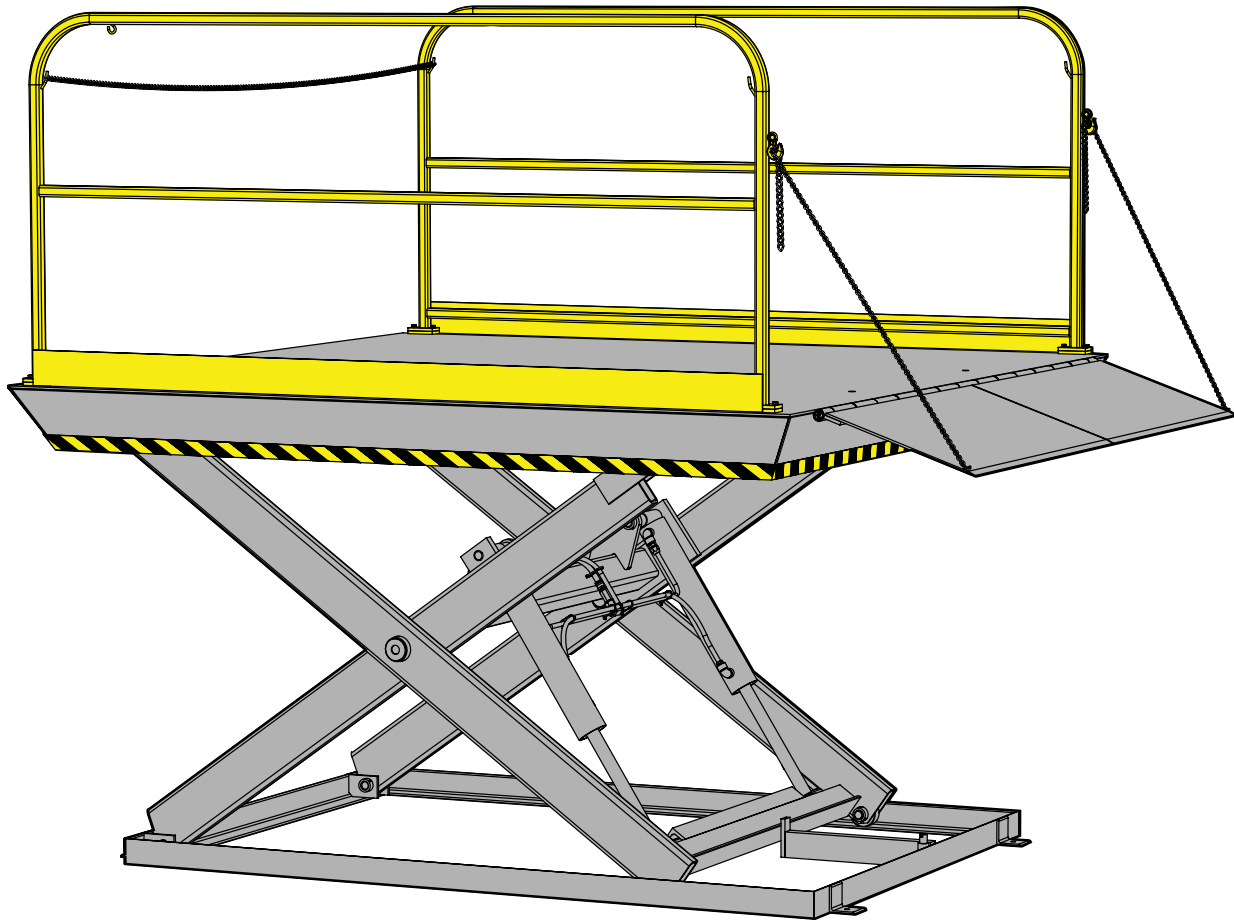

RITE
HITE®



This Manual Covers Dock Lifts Built After Serial Numbers:
07-LC450001C and up

PRINTED IN U.S.A.
RITE-HITE PRINT SHOP

PUBLICATION NO. 1239
RITE-HITE PART NO. 0128435
JULY 2008

NOTES

TABLE OF CONTENTS

Notice To User3
Safety Warnings4
Installation Instructions7

IMPORTANT

Read and understand contents of this manual prior to installation or operation of this equipment. For best results, have this product serviced by your authorized RITE-HITE® representative.

NOTICE TO USER

Your local RITE-HITE® representative provides a Planned Maintenance Program (P.M.P.) which can be fitted to your specific operation. Call your local representative or the RITE-HITE® Corporation at 414-355-2600.

The RITE-HITE® products in this manual are covered by one or more of the following U.S. patents: 4,865,507; 4,920,598; 4,995,130; 5,040,258; 5,271,183; 5,323,503; 5,375,965; 5,440,772; 5,442,825; 5,531,557; 5,546,623; 5,553,987; 5,582,498; 5,664,930; 5,702,223; 5,762,459 (RE: 37,570); 5,882,167; 5,964,572; 6,010,297; 6,052,268; 6,065,172; 6,070,283; 6,074,157; 6,085,375; 6,092,970; 6,106,212; 6,116,839; 6,190,109; 6,220,809; 6,627,016; 6,238,163; 6,311,352; 6,318,947; 6,322,310; 6,360,394; 6,368,043; 6,431,819; 6,488,464; 6,497,076; 6,499,169; 6,505,713; 6,524,053; 6,634,049; 6,654,976; 6,676,360; 6,726,432; 6,773,221; 6,832,403; 6,880,301; 7,032,267; 7,062,814; 7,134,159; 7,213,285; 7,216,391 and pending U.S and foreign patent applications. RITE-HITE®, LEVEL-RITE®, THINMAN™, SAFE-T-LIP®, HYDRACHEK®, WHEEL-LOK™, DOK-LOK®, DUAL-DOK®, SAFE-T-STRUT™, DOK-COMMANDER®, JUMBO™, HYDRA-RITE™, SAFE-T-GATE®, and SMOOTH TRANSITION DOK SYSTEM™, are trademarks of RITE-HITE® Corporation.

SAFETY WARNINGS

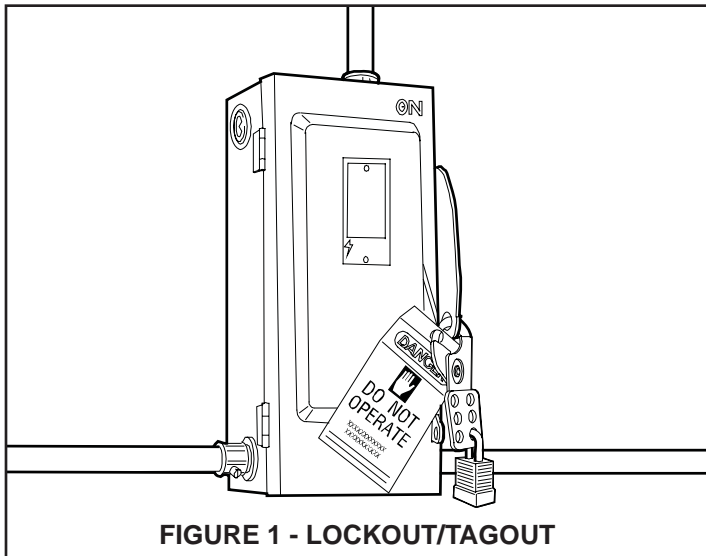

FIGURE 1 - LOCKOUT/TAGOUT

WARNING

When working with electrical or electronic controls, make sure that the power source has been locked out and tagged according to OSHA regulations and approved local electrical codes.

LOCKOUT/TAGOUT PROCEDURES

The Occupational Safety and Health Administration requires that, in addition to posting safety warnings and barricading the work area, the power supply has been locked in the OFF position or disconnected. It is mandatory that an approved lockout device is utilized. An example of a lockout device is illustrated. The proper lockout procedure requires that the person responsible for the repairs is the only person who has the ability to remove the lockout device.

In addition to the lockout device, it is also a requirement to tag the power control in a manner that will clearly note that repairs are under way and state who is responsible for the lockout condition. Tagout devices have to be constructed and printed so that exposure to weather conditions or wet and damp locations will not cause the tag to deteriorate or become unreadable.

RITE-HITE® Corporation does not recommend any particular lockout device, but recommends the utilization of an OSHA approved device (refer to OSHA regulation 1910.147). RITE-HITE® Corporation also recommends the review and implementation of an entire safety program for the Control of Hazardous Energy (Lockout/Tagout). These regulations are available through OSHA publication 3120.

DANGER

This is the highest level statement. Failure to follow the listed instructions will most likely result in severe injury or death.

CAUTION

The statements used with this level of warning deal with a safe operating procedure. If the procedure is ignored, the possibility of personal injury may exist.

WARNING

This is a statement of serious hazard. Failure to follow the listed instructions could place the individual at risk of serious injury or death.

IMPORTANT

IMPORTANT is used to draw attention to a procedure that needs to be followed to prevent machine or property damage.

OTHER IMPORTANT SAFETY WARNINGS

DANGER

Never be under the LRL platform or lip without:

- Engaging the Maintenance Strut.
- Turning off power to the control box.
- Locking out and tagging out the main power source, as shown under Safety Warnings on preceding page.

WARNING

Always barricade the LRL at ground level and dock level from any form of traffic when maintenance is required.

CAUTION

Inspect the LRL monthly to ensure that there are no broken or worn parts which could cause injury to personnel or damage to the equipment.

WARNING

- Before starting installation or maintenance, check and follow the safety procedures of the facility where the LRL is being installed.
- Never enter a truck/trailer until its brakes are set, air has been dumped from air ride suspension (if applicable), and you have visually inspected to be sure truck/trailer is securely held in place by a vehicle restraint or wheel chock per OSHA regulations.
- DO NOT operate with anyone under platform or in front of the lip.
- Keep hands, limbs and loose hair clear of equipment when operating. DO NOT wear loose clothing or jewelry while operating this equipment.
- When docklift is not in use, it is recommended to store it with the platform fully lowered.
- If a malfunction does occur, always call your authorized RITE-HITE® service representative immediately.

SAFETY DEVICES

DANGER

Never be under the LRL Series Elevating Dock Lift platform or lip without:

- Engaging the Maintenance Strut. See below right.
 - Press UP Button until platform reaches its highest position.
 - Place Maintenance Strut in position. See Figure 2.
 - Press DOWN Button until platform stops and Maintenance Strut is engaged.
- Lockout/Tagout power supply.
 - Turn off the power to the control box.
 - Lockout/tagout the main power source, as shown under Safety Warnings on the inside front cover of this manual.
 - Always barricade the dock lift at dock level and drive level to prevent any unauthorized use of the dock lift.

Remove the Maintenance Strut.

- For Maintenance Strut removal, raise the dock lift to its highest position. Return the Maintenance Strut to the proper storage position.
- If you are unable to install the Maintenance Strut properly, contact your authorized RITE-HITE® Service Representative or RITE-HITE® Customer Service at 1-800-456-0600.

CAUTION

- Post warnings and barricades at dock level and at drive level to indicate that work is being done around and under the lift table.

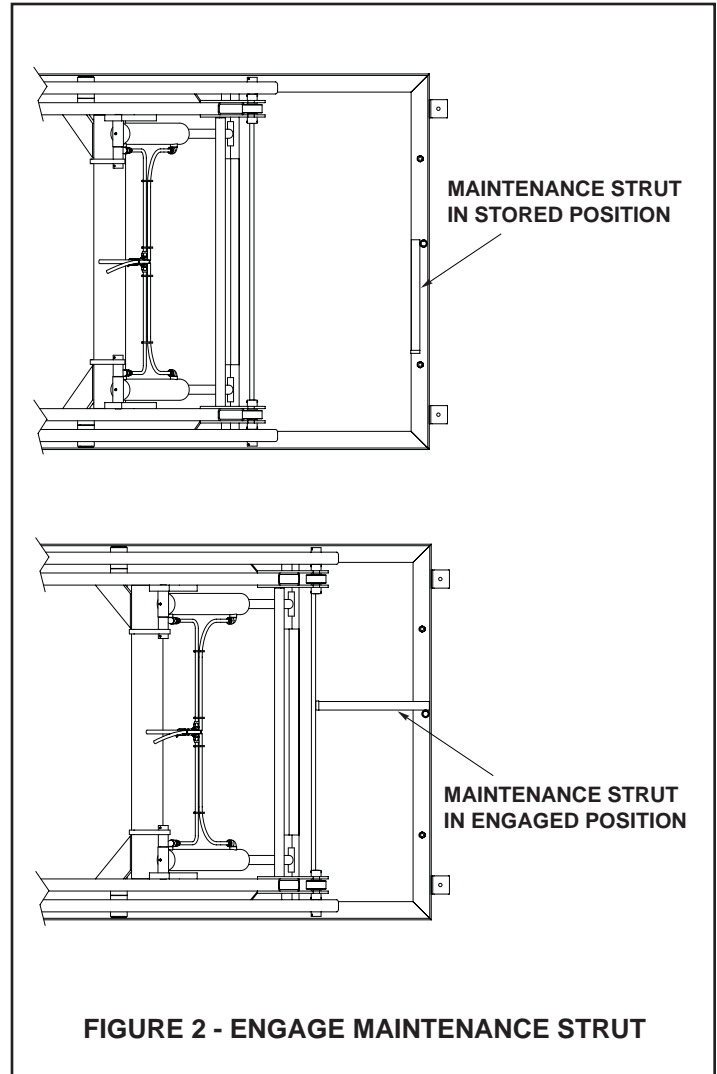

INSTALLATION INSTRUCTIONS

PIT DETAIL FOR LRL WITH ONE LIP ON ROLLING END

SIZE: 72" x 96" TO 96" x 120"

CAPACITY: 5, 6, 8 & 10,000 LBS

CONTACT RITE-HITE APPLICATIONS IF YOUR LRL DOES NOT MEET THESE REQUIREMENTS!

NOTES:

1. PERIMETER OF PIT FLOOR MUST BE KEPT LEVEL
2. PIT MUST BE KEPT SQUARE
3. PIT WIDTH AND LENGTH CALCULATION
 - A) ADD 2 INCHES TO WIDTH AND LENGTH
 - B) ADD 1 INCH FOR EACH LIP PER SIDE TO ALLOW FOR HINGE
4. LIP RECESS (IF REQUIRED)
 - LIP RECESS WIDTH = LIP WIDTH + 2 INCHES
 - LIP RECESS LENGTH = LIP LENGTH + 1/2 INCHES
5. CURB ANGLE LENGTH CALCULATION
 - 2 PIECES: PIT WIDTH
 - 2 PIECES: PIT LENGTH + 6 INCHES

EXAMPLE: 72" x 96" PLATFORM WITH LIP ON ROLLING END
 -WIDTH: $72 + 2 = 74$ INCHES WIDE
 -LENGTH: $96 + 2 + 1 = 99$ INCHES LONG

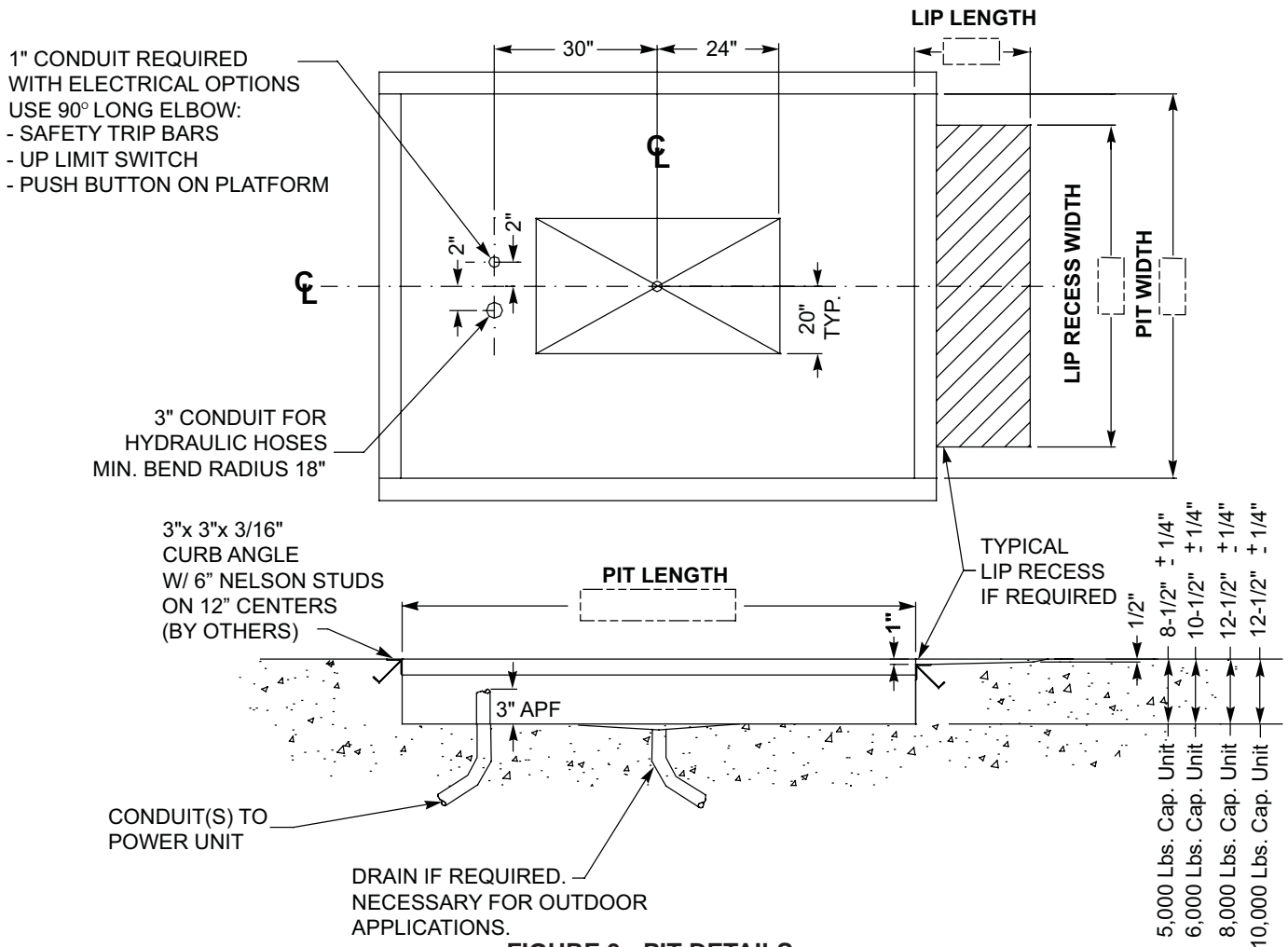

FIGURE 3 - PIT DETAILS

INSTALLATION INSTRUCTIONS - CONT.

DANGER

Make sure that the lift power has been locked out and tagged out according to OSHA regulations and approved local codes before performing any welding on the dock lift or when working on electrical or electronic controls.

WARNING

Make sure that the lifting equipment is rated for 4,000 Lbs. - (5 / 6K), or 5,000 Lbs. - (8 / 10K) lifting capacity or greater.

IMPORTANT

- Post safety warnings and barricade work area to prevent unauthorized use of the elevating dock lift while work is being performed.
- ALWAYS ground to the frame or pit angle when welding. DO NOT ground welding equipment to any electrical components. DO NOT ground to lift platform when welding on lift frame. Damage to bearings or electrical components may result.
- DO NOT connect green ground lead into control box or junction box until all welding is complete.
- Protect Hydraulic Hose assemblies from damage due to welding, grinding or sharp objects.
- DO NOT position the dock lift on its side or turn the dock lift topside down at any time.
- If a procedure is not clearly defined in this manual, contact your local representative or RITE-HITE® at 1-800-456-0600 before proceeding.

PREPARATION PRIOR TO INSTALLATION

1. Elevating dock lift is shipped equipped with lifting lugs. DO NOT remove until lift is resting in pit. (Lifting lugs prevent the lift table from opening when the lift table is lifted into place.)
2. Verify that dock lift voltage matches the voltage supplied.

INSTALLATION INTO PIT

1. Clean out pit and remove all debris from work area.
2. Attach lifting chain to dock lift and position as close to pit area as possible. See figure 4.
3. Disconnect hydraulic hoses from power unit. Feed hydraulic hoses through conduit.

NOTE: Hydraulic hoses MUST BE protected from any dirt or debris that could enter the system.

4. If equipped, disconnect wiring from power unit. Feed wiring through conduit.
5. Lower the dock lift into the pit while pulling the hydraulic hoses and wiring through the conduits.
6. Install hydraulic hoses to power unit and make necessary connections.

ELECTRICAL INSTALLATION PROCEDURES

1. Position power unit adjacent to the dock position.
2. Secure power unit in accordance with all local electrical codes.
3. Connect wiring as indicated by Electrical Schematics located in the control box.

Control Box Installation Guidelines - Temperature Controlled Applications.

- a. Conduit should be routed to enter through the bottom or side of the enclosure. A drip leg may be needed if the conduit could fill with water.
- b. Seal the conduit in any location where the conduit transitions temperature zones that may produce condensation.
- c. Spacers should be installed between the enclosure and the wall to provide temperature insulation and air flow.

INSTALLATION INSTRUCTIONS CONT.

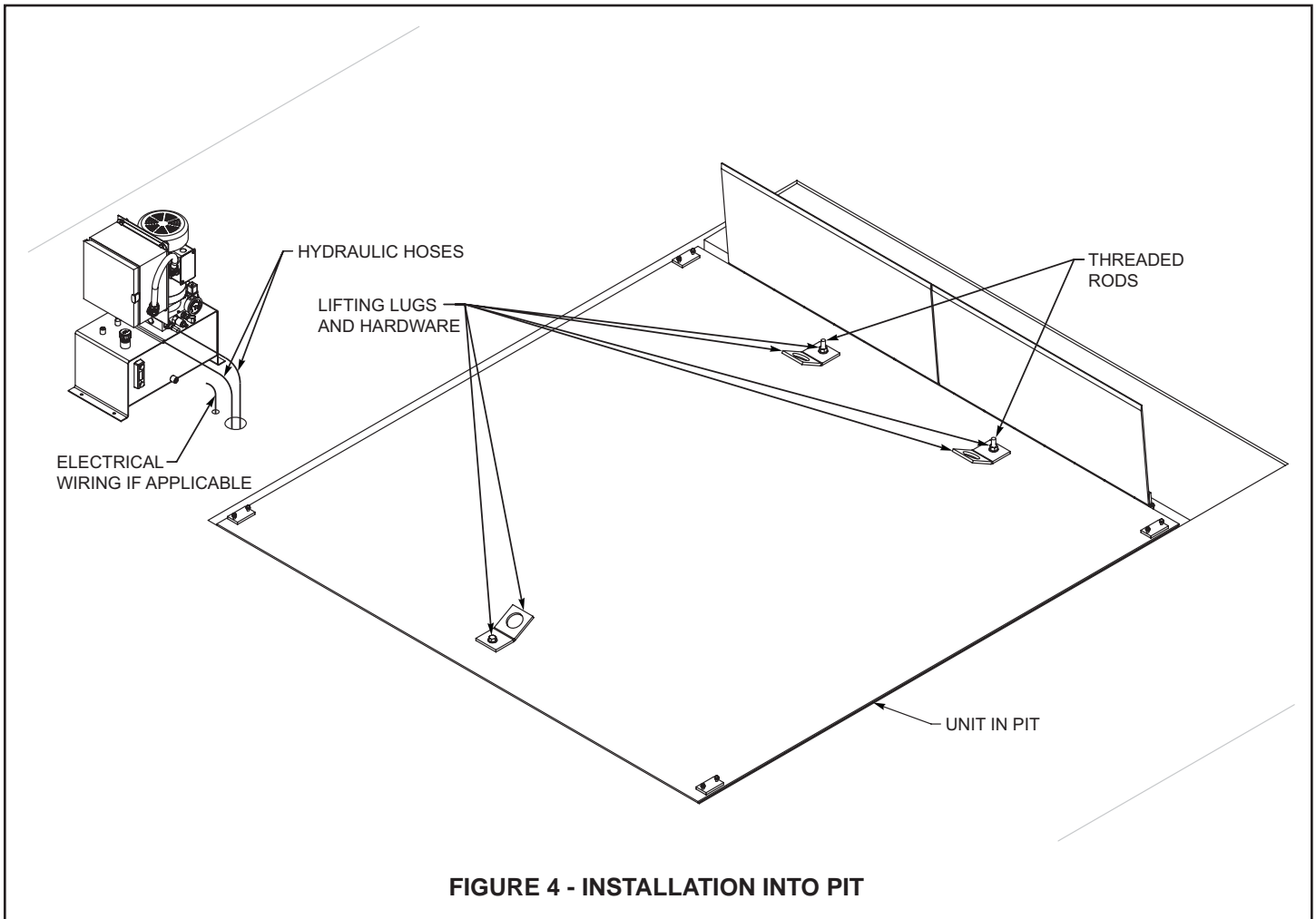

DANGER

Never be under the LRL platform or lip without:

- Engaging the Maintenance Strut.
- Turning off power to the control box.
- Locking out and tagging out the main power source, as shown under Safety Warnings.

INSTALLATION INSTRUCTIONS - CONT.

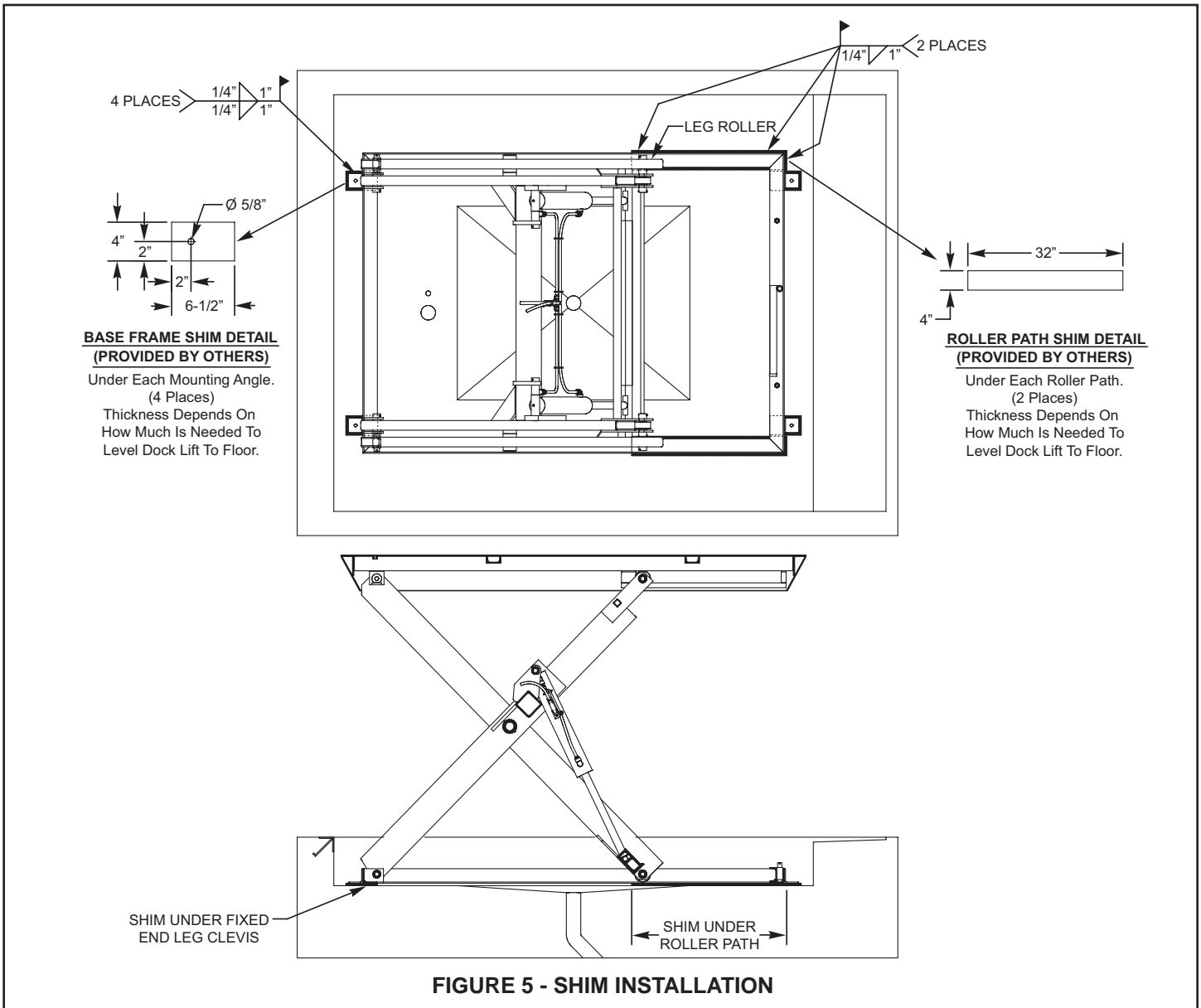

SHIM AND MOUNTING INSTALLATION WITH ELECTRICITY

1. Square dock lift in pit area with spaces equal on all sides.
2. Remove lifting lugs and hardware.
3. Turn on power.
4. Raise dock lift to working height and block at roller end with base mounted maintenance strut. See figure 2.
5. Remove the threaded rods from the frame angle upon installation. See figure 4.

IMPORTANT

- **ALWAYS** ground to the frame or front pit angle when welding. **DO NOT** ground welding equipment to any electrical components. **DO NOT** ground to lift platform when welding on lift frame. Damage to bearings or electrical components may result.
- **DO NOT** connect green ground lead into control box or junction box until all welding is complete.

INSTALLATION INSTRUCTIONS - CONT.

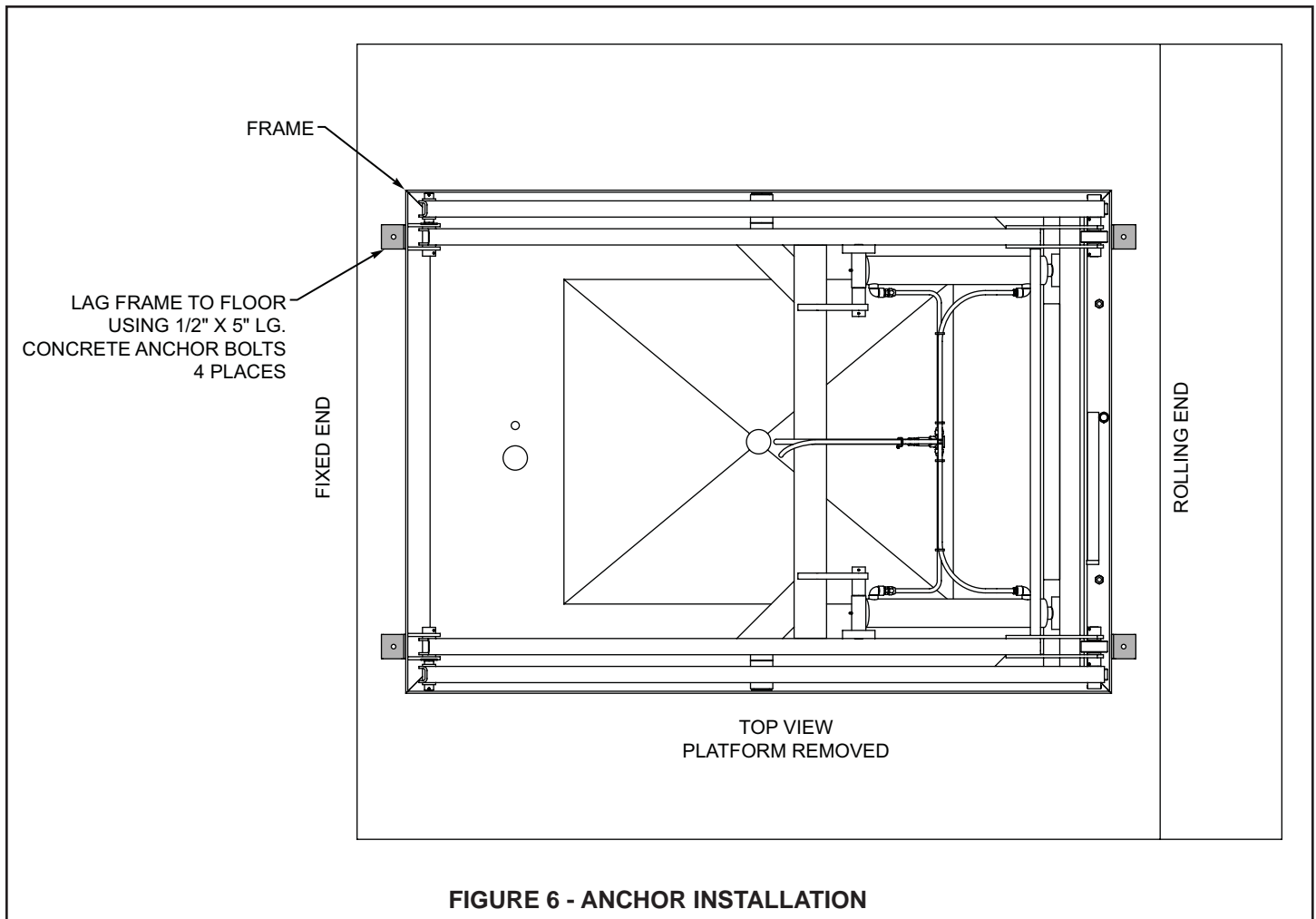

6. Shim dock lift so it is level with the floor. Install shims (provided by others) under each mounting angle (Qty. 4) and under each roller path (Qty. 2). See figure 5.
7. Disengage maintenance strut and lower unit to verify that dock lift is square in pit and level with the floor. Adjust and repeat previous steps as necessary.
8. Raise dock lift to working height and block at roller end with base mounted maintenance strut. See figure 2.
9. Using the hole in each mounting angle on the frame as a guide, drill a 1/2" diameter hole a minimum of 5" deep. Clean out hole. See figure 6.
10. Install 1/2" x 5" long concrete anchor bolts (provided by others) through hole in each mounting angle. See figure 6.
11. Weld all shims to frame. See figure 5.
12. Raise and lower dock lift at least three times to expel air from the system.
13. Verify that there are no oil leaks.

INSTALLATION COMPLETE!

INSTALLATION INSTRUCTIONS - CONT.

SHIM AND MOUNTING INSTALLATION WITHOUT ELECTRICITY

1. Square dock lift in pit area with spaces equal on all sides.
2. Determine how much shim thickness will be required to make the lift level with the floor.
3. Remove two front lifting lugs and hardware.
4. Remove the threaded rods from the frame angle upon installation. See figure 4 & 7.
5. Pull each threaded rod up until it stops and reinstall the lifting lugs and hardware. See figure 7 & 8.
6. Attach three-way lifting chain to lifting lugs and crane. See figure 8.
7. Raise dock lift to working height with crane and block at roller end with base mounted maintenance strut. See figure 2 & 8. While raising the dock lift, the hydraulic lifting cylinders will be pulled off of their mounting angle. The cylinders should remain retracted. See figure 8. Keep tension on the lifting chains while working under the dock lift.
8. Shim dock lift so it is level with the floor. Install shims (provided by others) under each mounting angle (Qty. 4) and under each roller path (Qty. 2). See Figure 5.
9. Using the hole in each mounting angle on the frame as a guide, drill a 1/2" diameter hole a minimum of 5" deep. Clean out hole. See Figure 6.
10. Install 1/2" x 5" long concrete anchor bolts (provided by others) through hole in each mounting angle. See Figure 6.

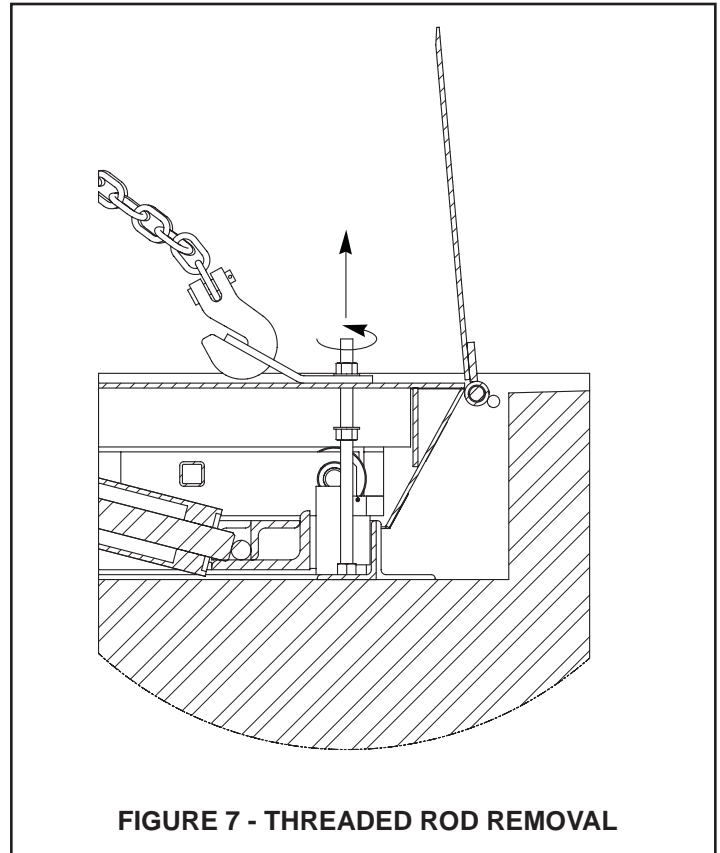

FIGURE 7 - THREADED ROD REMOVAL

IMPORTANT

- **DO NOT lower the lift without electricity. Damage to the hydraulic lifting cylinders and their mounting angles could occur!**

IMPORTANT

- **ALWAYS ground to the frame or front pit angle when welding. DO NOT ground welding equipment to any electrical components. DO NOT ground to lift platform when welding on lift frame. Damage to bearings or electrical components may result.**
- **DO NOT connect green ground lead into control box or junction box until all welding is complete.**

11. Weld all shims to frame. See Figure 5.

INSTALLATION INSTRUCTIONS - CONT.

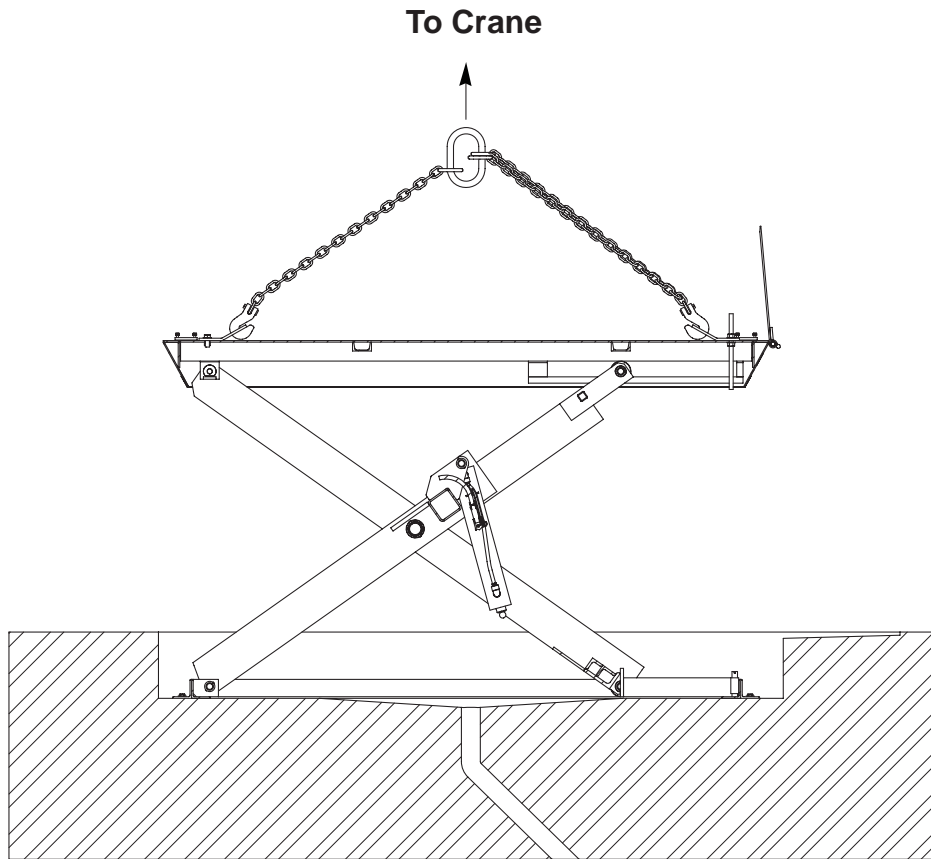

FIGURE 8 - CRANE LIFTING

ONCE ELECTRICITY HAS BEEN RESTORED

1. Verify that powerunit has been electrically connected and hydraulic hoses have also been connected properly.
2. Press the RAISE pushbutton to allow the hydraulic lifting cylinders to extend their rods. Stop extending the cylinder rods just before the cylinder mounting angle. See Figure 9.
3. With someone assisting you, continue to press the RAISE pushbutton while they guide the cylinder rods into the cylinder mounting angle. See Figure 9.
4. Disengage maintenance strut and lower unit to verify that dock lift is square in pit and level with the floor.
5. Raise and lower dock lift at least three times to expel air from the system.
6. Verify that there are no oil leaks.

INSTALLATION COMPLETE!

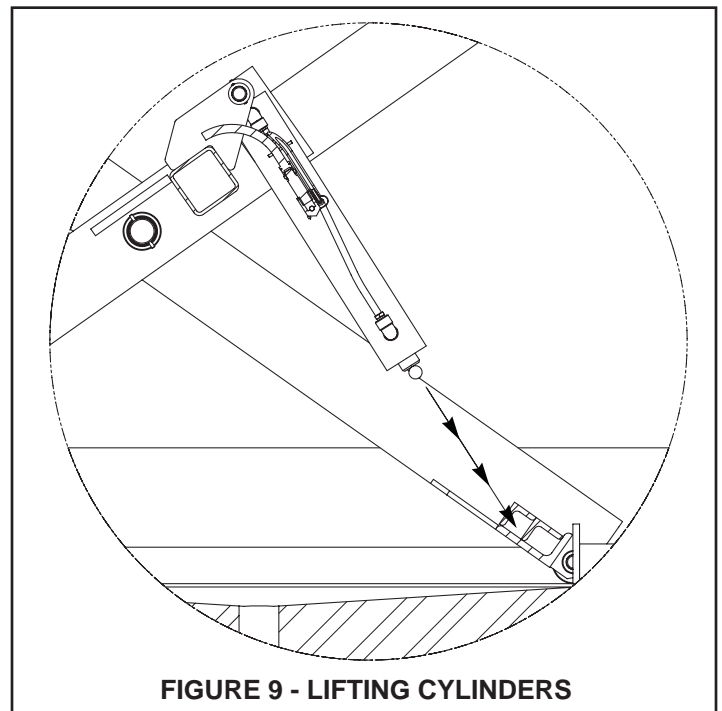

FIGURE 9 - LIFTING CYLINDERS

NOTES

NOTES

RITE-HITE® STANDARD WARRANTY

Rite-Hite® warrants that its products will be free from defects in design, materials, and workmanship for a period of 365 days from the date of shipment. All claims for breach of this warranty must be made within 30 days after the defect is or can, with reasonable care, be detected and in no event no more than 30 days after the warranty has expired. In order to be entitled to the benefits of this warranty, the products must have been properly installed, maintained, and operated within their rated capacities and/or specified design parameters, and not otherwise abused. Periodic lubrication and adjustment is the sole responsibility of the owner. This warranty is Rite-Hite's® exclusive warranty. Rite-Hite® expressly disclaims all implied warranties, including the implied warranties of merchantability and fitness. Non-standard warranties, if any, must be specified by Rite-Hite® in writing.

In the event of any defects covered by this warranty, Rite-Hite® will remedy such defects by repairing or replacing any defective equipment or parts, bearing all the costs for parts, labor, and transportation. This shall be the exclusive remedy for all claims whether based on contract, negligence, or strict liability.

LIMITATION OF LIABILITY

RITE-HITE® SHALL NOT IN ANY EVENT BE LIABLE FOR ANY LOSS OF USE OF ANY EQUIPMENT OR INCIDENTAL OR CONSEQUENTIAL DAMAGES OF ANY KIND, WHETHER FOR BREACH OF WARRANTY, NEGLIGENCE, OR STRICT LIABILITY.



Global Sales & Service Office:

RITE-HITE®

8900 N. Arbon Drive

P.O. Box 245020

Milwaukee, Wisconsin 53224

Phone: 414-355-2600

1-800-456-0600

www.ritehite.com

Representatives in all Major Cities