

Rite-Hite® & *genisys* By Rite-Hite

Dock Leveler Installation Manual

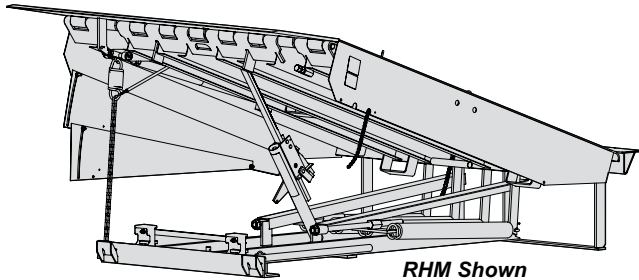

RHM Shown

RHM & ML-900 Mechanical Dock Leveler *part of the SMOOTH TRANSITION DOK SYSTEM™*

RHH Hydra-Rite™ / Base & HL-900 Hydraulic Dock Leveler

part of the SMOOTH TRANSITION DOK SYSTEM™

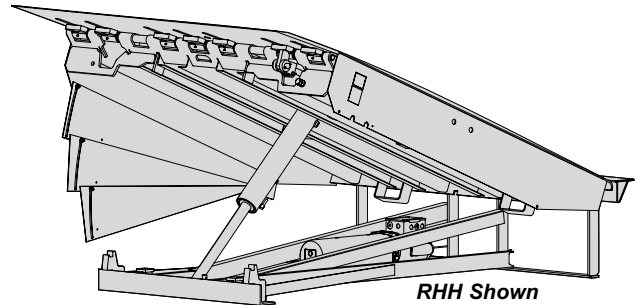

RHH Shown

RHA & AL-900 Air Powered Dock Leveler

part of the SMOOTH TRANSITION DOK SYSTEM™

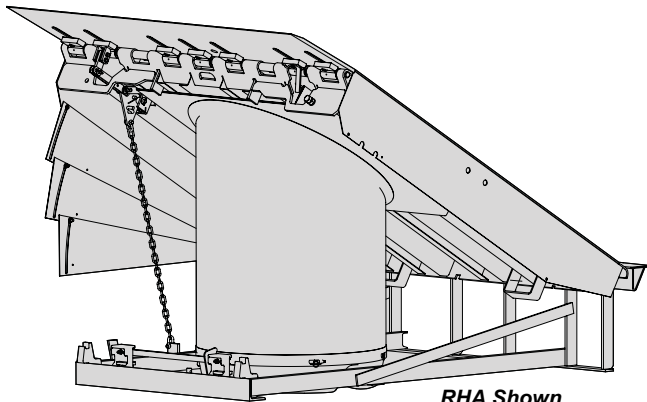

RHA Shown

RITE HITE®



This Manual Covers Levelers Built After Serial Numbers:

RHM Series: 04ID410001M and up **RHH Series:** 05BD480001M and up **RHA Series:** 04ID400001M and up
ML Series: 04CD100001M and up **HL Series:** 04CD120001M and up **AL Series:** 04CD130001M and up

TABLE OF CONTENTS

NOTICE TO USER	2
SAFETY WARNINGS	3
INSTALLATION INSTRUCTIONS	7
SHIMMING DETAIL	10
LEVELER ADJUSTMENTS	17
BUMPER INSTALLATION	18
LIP SUPPORT INSTALLATION	19
TYPICAL COMPLETE INSTALL	20
GENISYS WARRANTY	23
RITE-HITE WARRANTY	BACK COVER

NOTICE TO USER

Your local RITE-HITE® representative provides a Planned Maintenance Program (P.M.P.) which can be fitted to your specific operation. Call your local representative or the RITE-HITE® Corporation at 414-355-2600.

The RITE-HITE® products in this manual are covered by one or more of the following U.S. patents: 5,271,183; 5,323,503; 5,546,623; 5,553,987; 5,582,498; 5,664,930; 5,702,223; 5,762,459 (RE: 37,570); 5,882,167; 6,065,172; 6,070,283; 6,085,375; 6,092,970; 6,106,212; 6,116,839; 6,190,109; 6,220,809; 6,276,016; 6,311,352; 6,318,947; 6,322,310; 6,360,394; 6,368,043; 6,431,819; 6,488,464; 6,499,169; 6,502,268; 6,505,713; 6,524,053; 6,634,049; 6,654,976; 6,726,432; 6,773,221; 6,832,403; 6,880,301; 6,892,411; 7,032,267; 7,062,814; 7,134,159; 7,213,285; 7,216,391; 7,363,670; 7,380,305; 7,503,089; 7,553,431; 7,584,517; 7,681,271; 7,823,239; 7,841,823; 7,877,831 and pending U.S and foreign patent applications. RITE-HITE®, LEVEL-RITE®, THINMAN™, SAFE-T-LIP®, HYDRACHEK®, WHEEL-LOK™, DOK-LOK®, DUAL-DOK®, SAFE-T-STRUT™, DOK-COMMANDER®, JUMBO™, HYDRA-RITE™, SAFE-T-GATE®, and SMOOTH TRANSITION DOK SYSTEM™, are trademarks of RITE-HITE® Corporation.

SAFETY WARNING

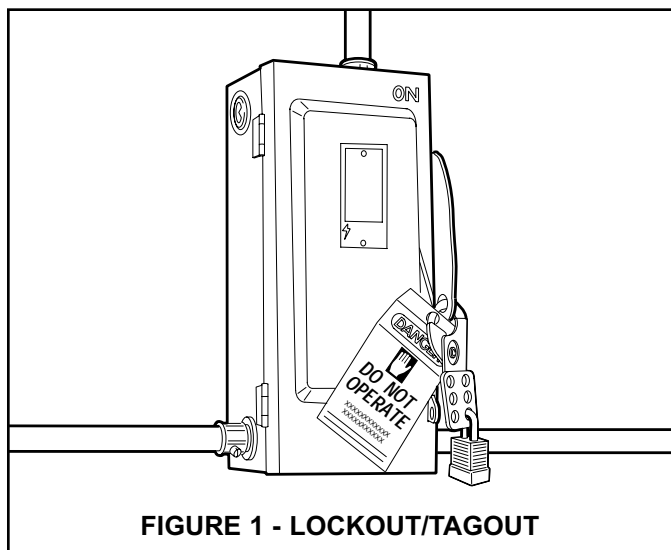

WARNING

When working with electrical or electronic controls, make sure that the power source has been locked out and tagged out according to OSHA regulations and approved local electrical codes.

LOCKOUT/TAGOUT PROCEDURES

The Occupational Safety and Health Administration (OSHA) requires, in addition to posting safety warnings and barricading the work area (including, but not limited to, trucking office and loading docks), that the power supply has been locked in the OFF position or disconnected. It is mandatory that an approved lockout device is utilized. An example of a lockout device is illustrated. The proper lockout procedure requires that the person responsible for the repairs is the only person who has the ability to remove the lockout device.

In addition to the lockout device, it is also a requirement to tag the power control in a manner that will clearly note that repairs are under way and state who is responsible for the lockout condition. Tagout devices have to be constructed and printed so that exposure to weather conditions, or wet and damp locations, will not cause the tag to deteriorate or become unreadable.

RITE-HITE® does not recommend any particular lockout device, but recommends the utilization of an OSHA approved device (refer to OSHA regulation 1910.147). RITE-HITE® also recommends the review and implementation of an entire safety program for the Control of Hazardous Energy (Lockout/Tagout). These regulations are available through OSHA publication 3120.

DANGER

This is the highest level statement. Failure to follow the listed instructions will most likely result in severe injury or death.

CAUTION

The statements used with this level of warning deal with a safe operating procedure. If the procedure is ignored the possibility of personal injury may exist.

WARNING

This is a statement of serious hazard. Failure to follow the listed instructions could place the individual at risk of serious injury or death.

IMPORTANT

IMPORTANT is used to draw attention to a procedure that needs to be followed to prevent machine damage.

OTHER IMPORTANT OPERATIONAL SAFETY WARNINGS

DANGER

Never be under the dock leveler platform or lip without:

- Installing the Safe-T-Strut™ or other supporting device.
- If lip needs to be extended, follow procedures shown under Safety Devices on the following page.
- Turning off power to the control box.
- Locking out and tagging out the main power source, as shown under Safety Warnings on preceding page.

WARNING

Always barricade the dock leveler at ground level and dock level from any form of traffic when maintenance is required.

CAUTION

Inspect the dock leveler monthly to ensure that there are no broken or worn parts which could cause injury to personnel or damage to the equipment.

WARNING

- Before starting installation or maintenance, check and follow the safety procedures of the facility where the dock leveler is being installed.
- Never enter a truck/trailer until its brakes are set, air has been dumped from air ride suspension (if applicable), and you have visually inspected to be sure truck/trailer is securely held in place by a vehicle restraint or wheel chock per OSHA regulations.
- Never operate the leveler with you, anyone, or anything on, or in front of the leveler, or without a truck/trailer parked in position, or from on the truck/trailer bed.
- DO NOT operate with anyone under platform or in front of the lip.
- When leveler is not in use, always store it so that it is supported by the lip supports and that it is level with the surrounding dock floor.
- If a malfunction does occur, always call your authorized RITE-HITE® service representative immediately.

SAFETY DEVICES RITE-HITE LEVELERS

⚠ DANGER

Never be under the dock leveler platform or lip without:

- Installing the Safe-T-Strut™. See below right. This can be done with the assistance of another person by:
 - Raise leveler until platform reaches its highest position and lip extends. Continue to maintain this position.
 - Then have assistant insert the smaller end of the Safe-T-Strut™ through the hole in the middle of the leveler lip and place the strut's wider open end over the base located on the leveler's front frame. Align the holes on the base and the Safe-T-Strut™ so that the leveler may be secured with the retaining pin and safety clip.
 - Release the push button on powered levelers allowing the Safe-T-Strut™ to rest on the underside of the lip.
- Lockout/Tagout power supply.
 - Turn off the power to the control box.
 - Lockout/tagout the main power source, as shown under Safety Warnings on the inside front cover of this manual.
 - Always barricade the leveler at dock level and drive level to prevent any unauthorized use of the leveler.

Remove the Maintenance Support.

- For Safe-T-Strut™ removal, have an assistant raise the leveler to its highest position with lip fully extended. Release the safety clip and remove retaining pin. Lift strut off base, and remove from lip. Return the Safe-T-Strut™ to the proper storage position.
- If you are unable to install the Maintenance Support properly, contact your authorized RITE-HITE® Service Representative or RITE-HITE® Customer Service at 1-414-355-2600.

⚠ CAUTION

- Post warnings and barricades at dock level and at drive level to indicate that work is being done around and under the leveler platform.
- Lockout/Tagout power to the leveler and post warnings when work is being performed on the leveler.

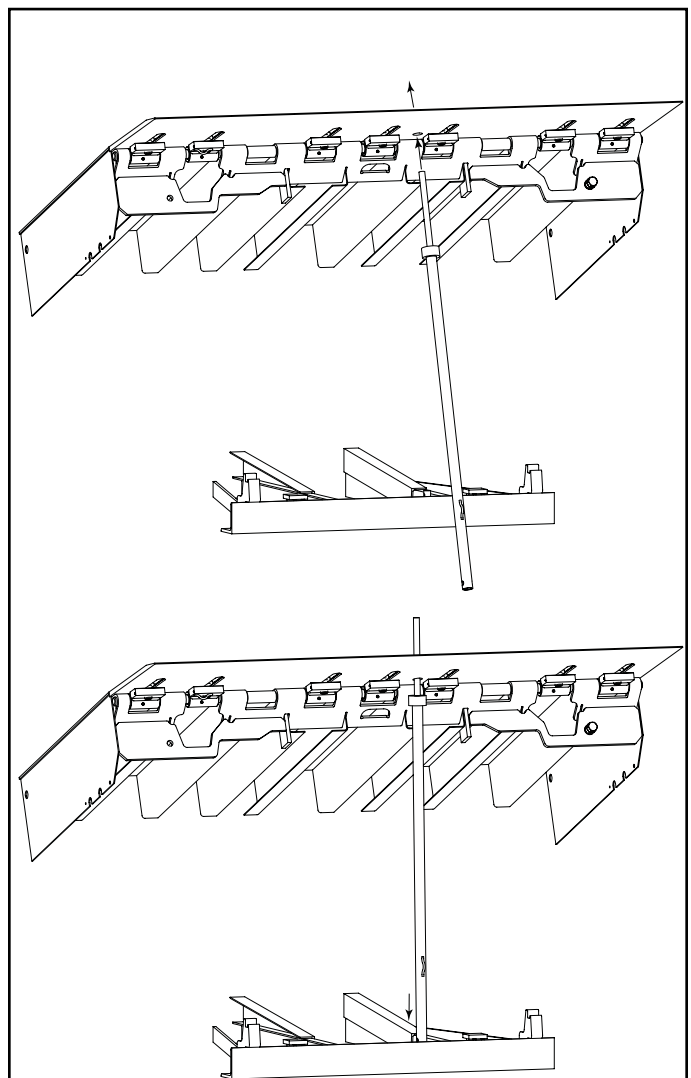

FIGURE 2 - INSTALL SAFE-T-STRUT™ SUPPORT

SAFETY DEVICES GENISYS LEVELERS

DANGER

Never be under the dock leveler platform or lip without:

- Installing the Maintenance Support. See below right. This can be done with the assistance of another person by:
 - Raise leveler until platform reaches its highest position and lip extends. Continue to maintain this position.
 - Then have assistant insert the Maintenance Support over the base located on the leveler's front frame.
 - Release the pushbutton on powered levelers allowing the support to rest inside the lip cup on the underside of the lip.
- Lockout/Tagout power supply.
 - Turn off the power to the control box.
 - Lockout/tagout the main power source, as shown under Safety Warnings on the inside front cover of this manual.
 - Always barricade the leveler at dock level and drive level to prevent any unauthorized use of the leveler.

Remove the Maintenance Support.

- For Maintenance Support removal, have an assistant raise the leveler to its highest position with lip fully extended. Lift the support off base. Return the Maintenance Support to the proper storage position.
- If you are unable to install the Maintenance Support properly, contact your authorized RITE-HITE® Service Representative or RITE-HITE® Customer Service at 1-414-355-2600.

CAUTION

- Post warnings and barricades at dock level and at drive level to indicate that work is being done around and under the leveler platform.
- Lockout/Tagout power to the leveler and post warnings when work is being performed on the leveler.

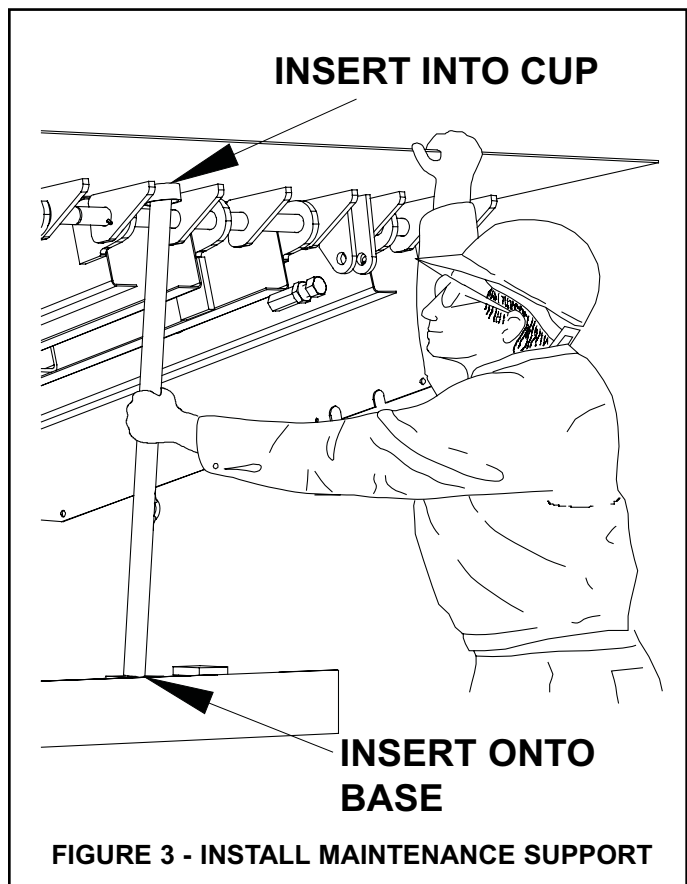

INSTALLATION INSTRUCTIONS

PREPARATION PRIOR TO INSTALLATION

1. Check pit to insure it meets pit details. If pit does not match pit details, contact your local representative or RITE-HITE® before proceeding.
NOTE: Unit may not operate properly if pit is not correct.
2. Leave shipping bands on leveler until instructed to remove them.
3. **RHA and AL Series Only:** Verify there are no protrusions from the pit floor located under the tower assembly. If so, remove protrusions as required. (example: grind down anchor bolt heads)
4. **RHH, HL, RHA and AL Series Only:** Verify that leveler voltage matches the voltage supplied at pit, and that proper electrical junction box or weatherproof outlet has been installed.
5. Clean out pit and remove all debris from work area.

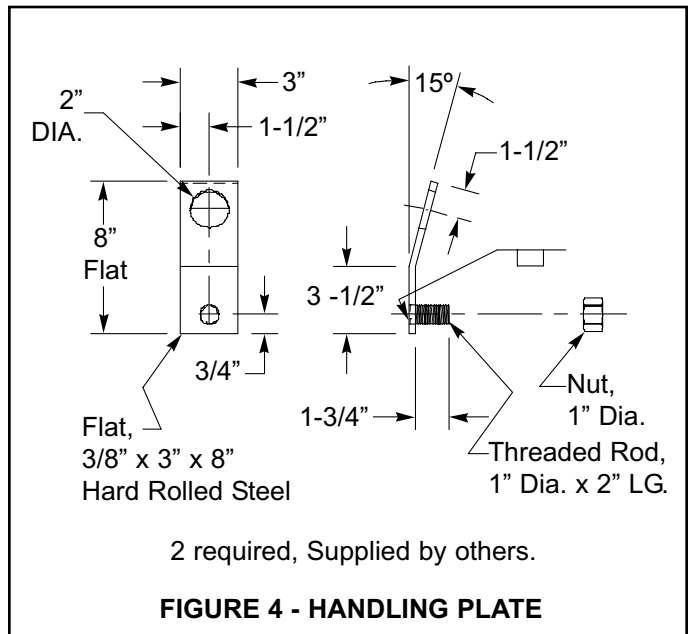

INSTALLATION PROCEDURES

1. Handling plates must be inserted into the forward handling holes of the toe guards. See Figure 4 and 5.
2. Attach lifting chain, lift leveler and position above pit. Lower leveler into pit. See Figure 5.

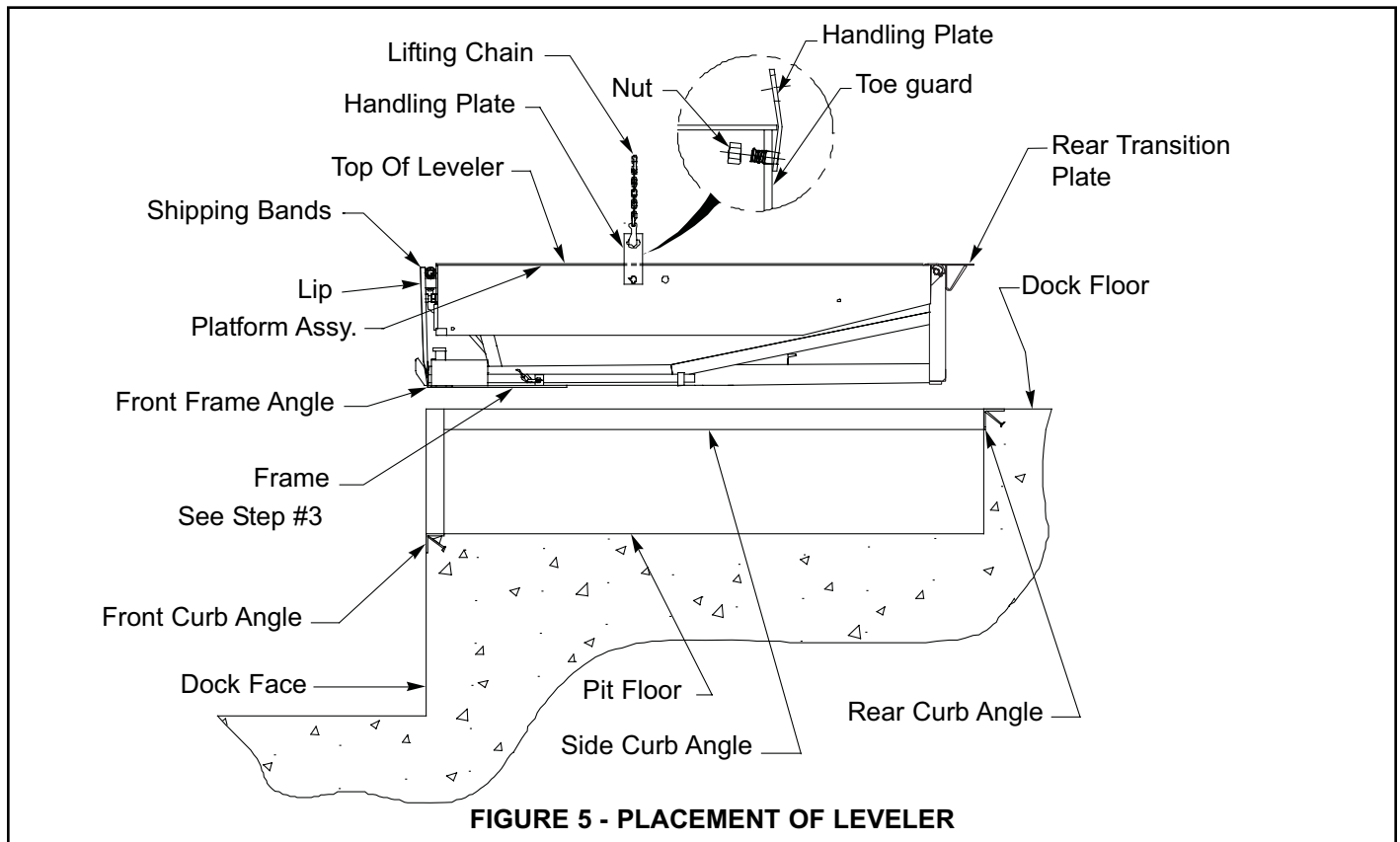

INSTALLATION INSTRUCTIONS CONT.

3. Center leveler in pit so that equal gaps are maintained on each side of the leveler. See Figure 6.
4. Push leveler straight back until the front frame angle is flush with the front curb angle. If the pit is not square, push leveler straight back until the front frame angle is completely behind the front curb angle by no more than 1/4 inch. The front frame angle should never extend past the front curb angle.

NOTES:

- a. If the leveler cannot be pushed back far enough, the back edge of the rear transition plate can be cut off up to 1 inch. If trimming the back edge of angle does not allow frame to be positioned properly in pit, contact your local representative or RITE-HITE® for assistance. Check the area between the rear transition plate and the back of the pit. If a gap exists, place spacers between the rear transition plate and the rear curb angle. Tack weld spacers to the rear transition plate only. See Figure 7 and 8.
- b. Minimum electrode must be 1/8", 7018 or better.

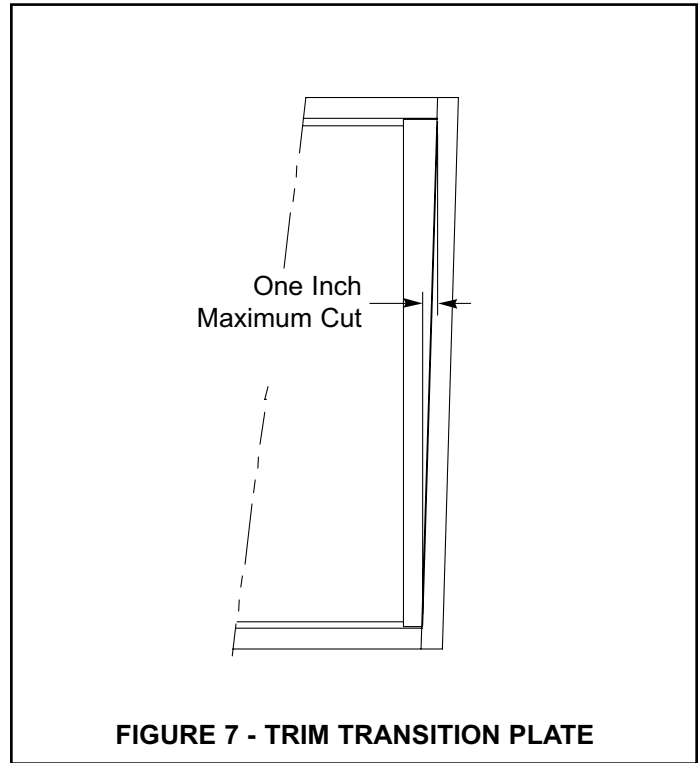

FIGURE 7 - TRIM TRANSITION PLATE

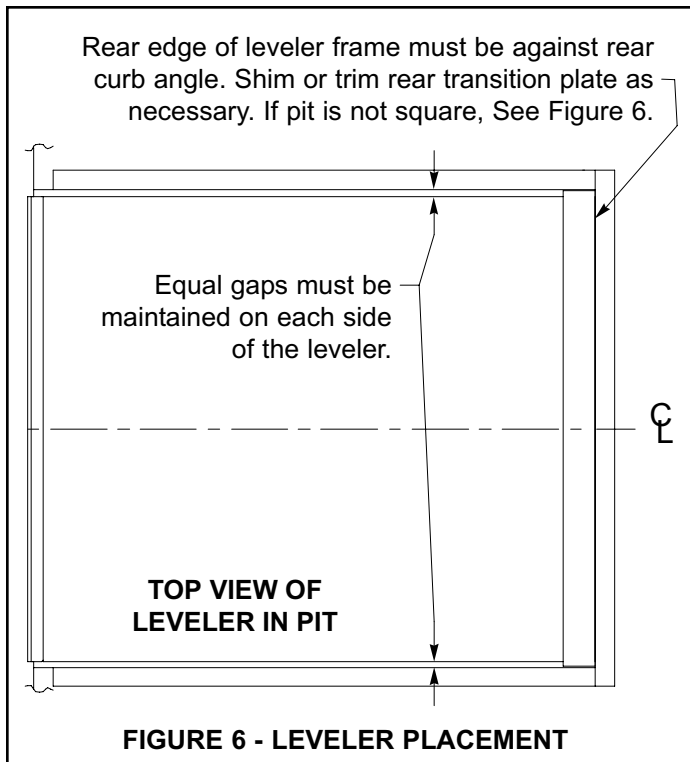

FIGURE 6 - LEVELER PLACEMENT

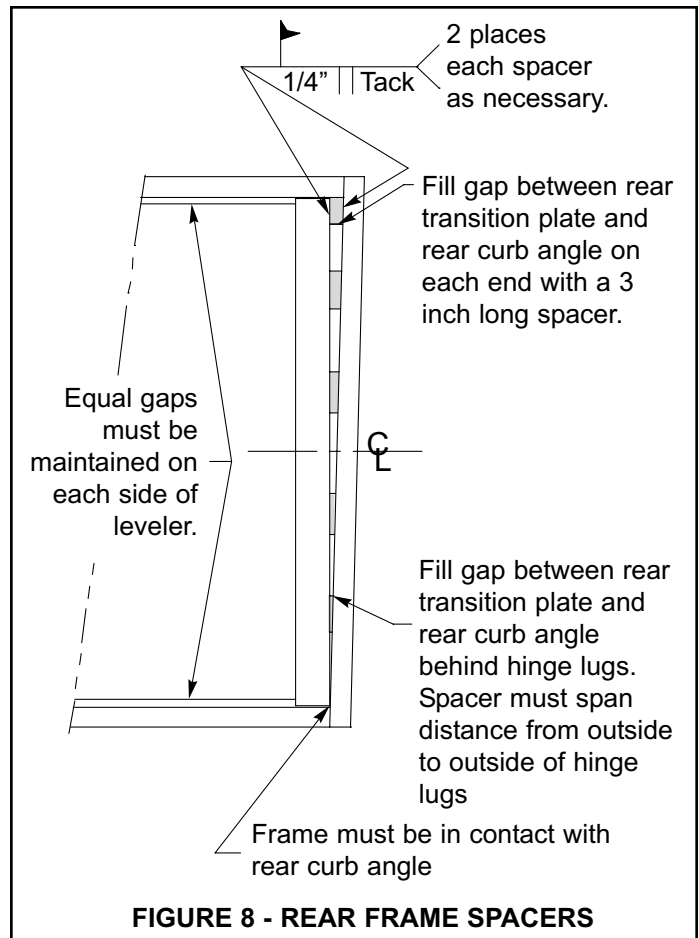

FIGURE 8 - REAR FRAME SPACERS

INSTALLATION INSTRUCTIONS CONT.

IMPORTANT

- **ALWAYS** ground to the frame or front pit angle when welding. **DO NOT** ground welding equipment to any electrical components. **DO NOT** ground to leveler platform when welding on leveler frame. Damage to bearings or electrical components may result.
- **DO NOT** connect green ground lead into control box or junction box until all welding is complete.
- **Protect Air Tower, Motors, Hose and Hydraulic Lines from damage due to welding, grinding or sharp objects.**

5. Remove lifting chain from handling plates.
6. Lift front frame of leveler until platform is level with dock floor. Cut and place shims under below dock stops, located on front frame angle and maintenance support base. Tack shims together and to front frame angle. See Figure 14.

IMPORTANT: For model specific shimming details see Figures 9 through 12.

NOTE: For levelers with 20 inch lips, lift bottom of front frame angle until it is at 19-1/2 inches below dock floor, and add shims. See Figure 14.

CAUTION

Shipping bands are under tension. Wear safety glasses and protective gloves. Stand to one side when cutting bands to avoid being cut by the bands.

7. Remove and discard all shipping bands.

8. Place a mark on the face of the front frame angle to indicate the frame centerline. Also, place a mark on the face of the lip to indicate the lip/platform centerline.
9. Shift the front frame angle sideways so that the frame centerline matches up with the lip/platform centerline (using the lines drawn earlier). Once frame and platform have been centered in the pit, tack weld the front frame angle and shims to the front curb angle.
10. **Mechanical leveler:** Pull and hold the release chain to raise the platform. Install maintenance support.
Powered leveler: Manually raise platform and extend lip on powered levelers. Install maintenance support.
11. Remove handling plates from platform.
12. Lift rear frame of leveler until platform is level with dock floor. Cut and place shims under the rear frame support posts. Tack shims together and to rear frame angle. See Figure 14.

Mechanical leveler: Be sure to shim underneath the snubbing cable mount on front frame angle. See Figures 9 through 14.

Hydraulic leveler (Base & HL Only): Place shims underneath the main cylinder clevis on frame as shown. See Figures 9 through 14.

IMPORTANT: Insure all shims are in place at this time. Tack shims together and to frame. See Figures 9 through 13.

INSTALLATION INSTRUCTIONS CONT.

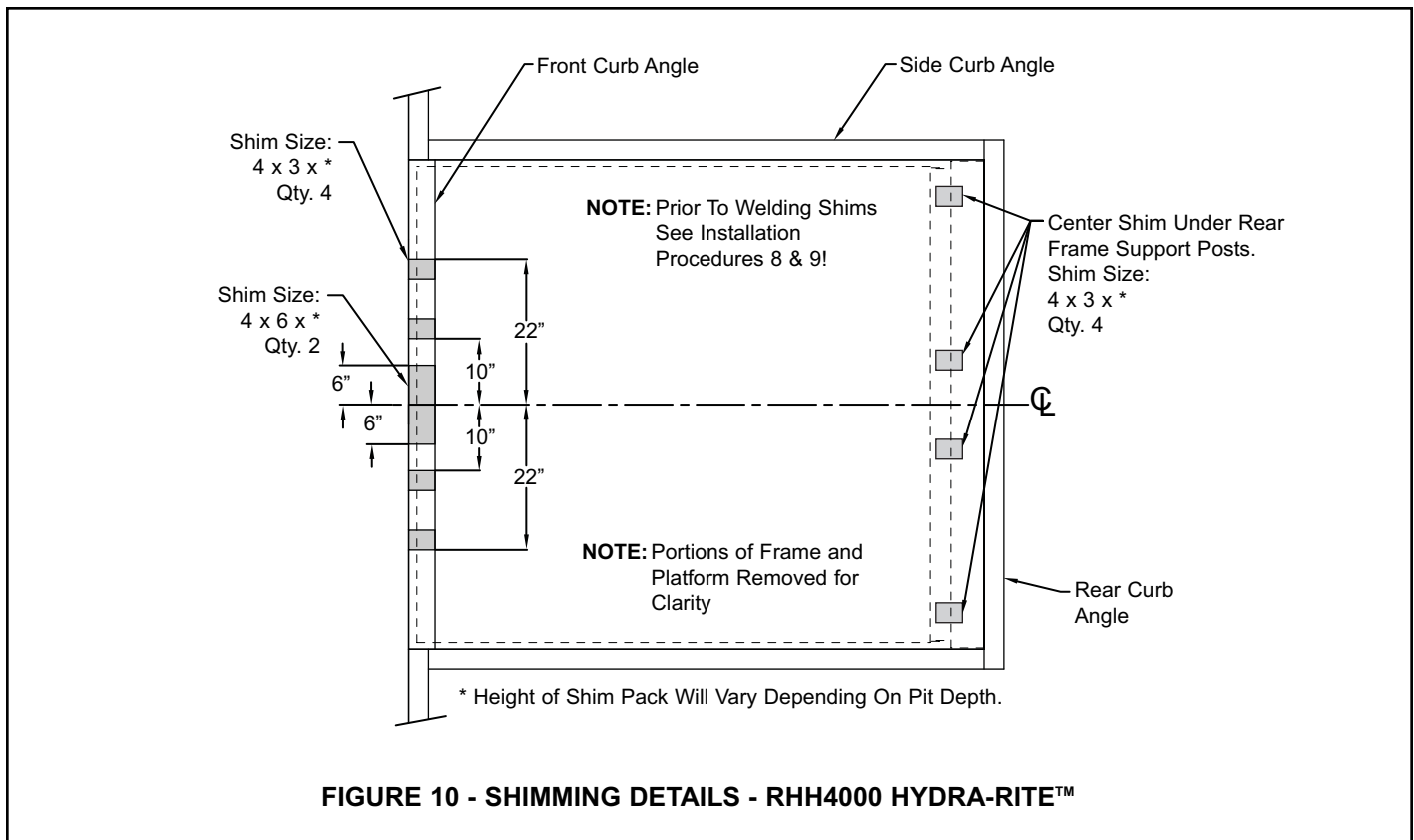
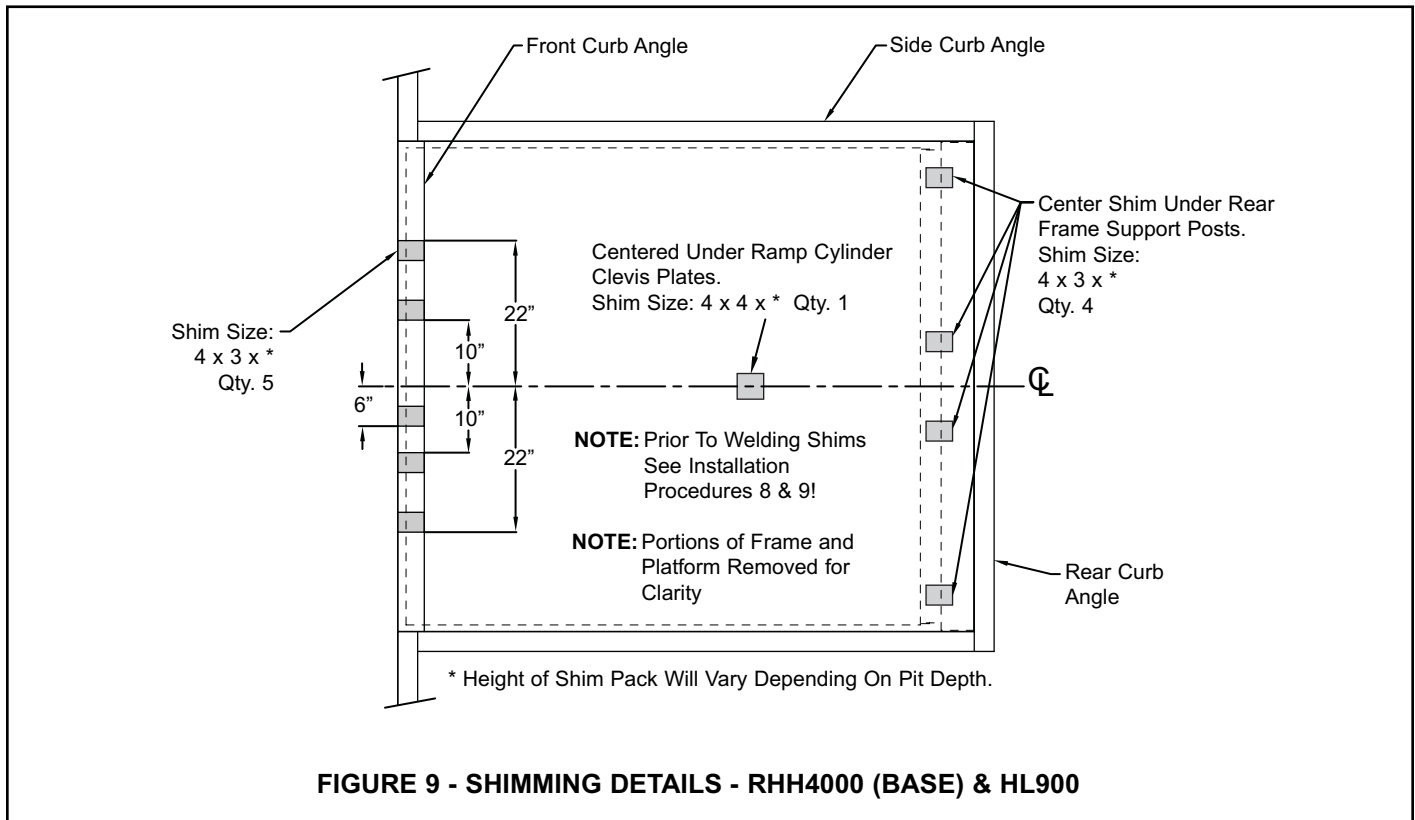

INSTALLATION INSTRUCTIONS CONT.

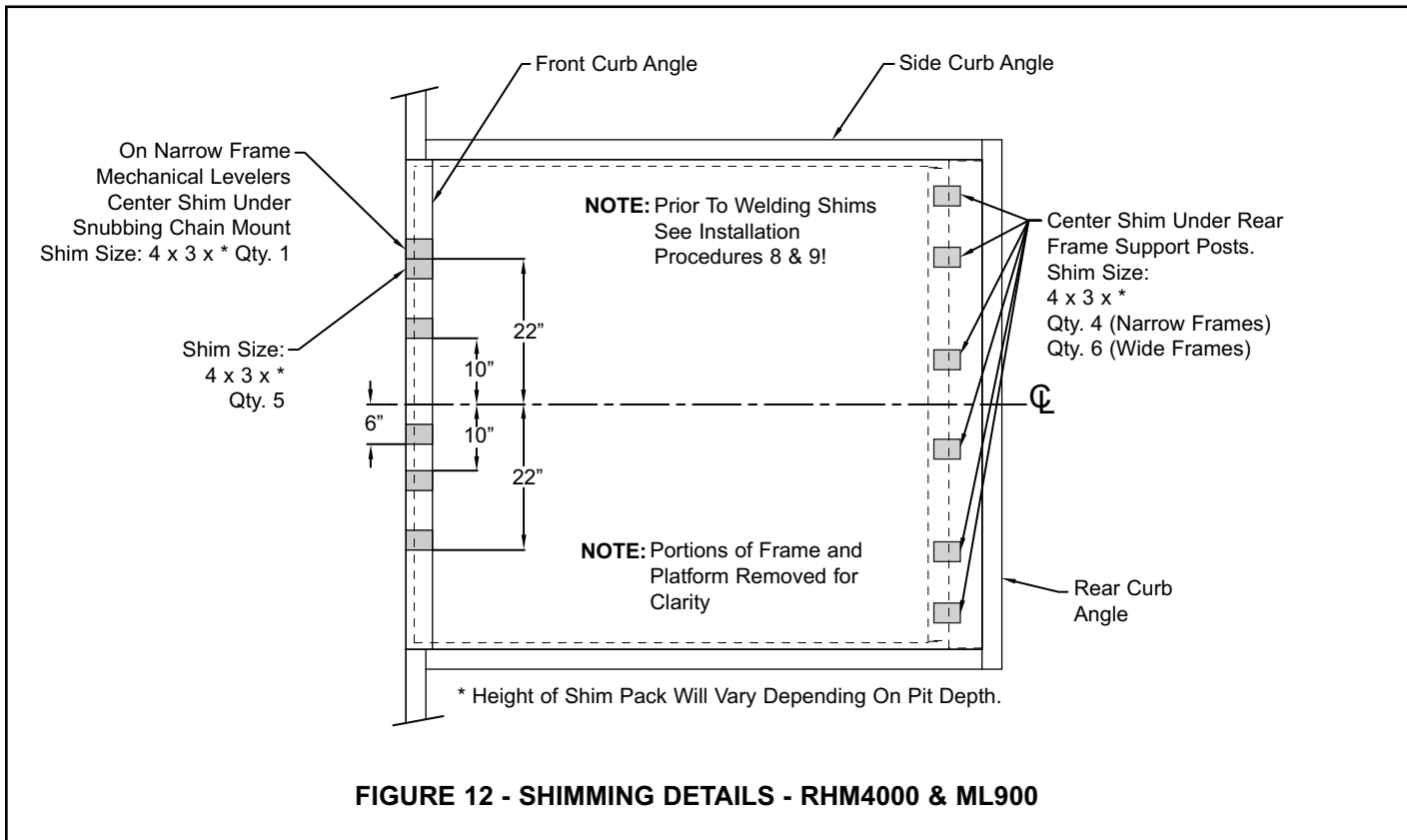
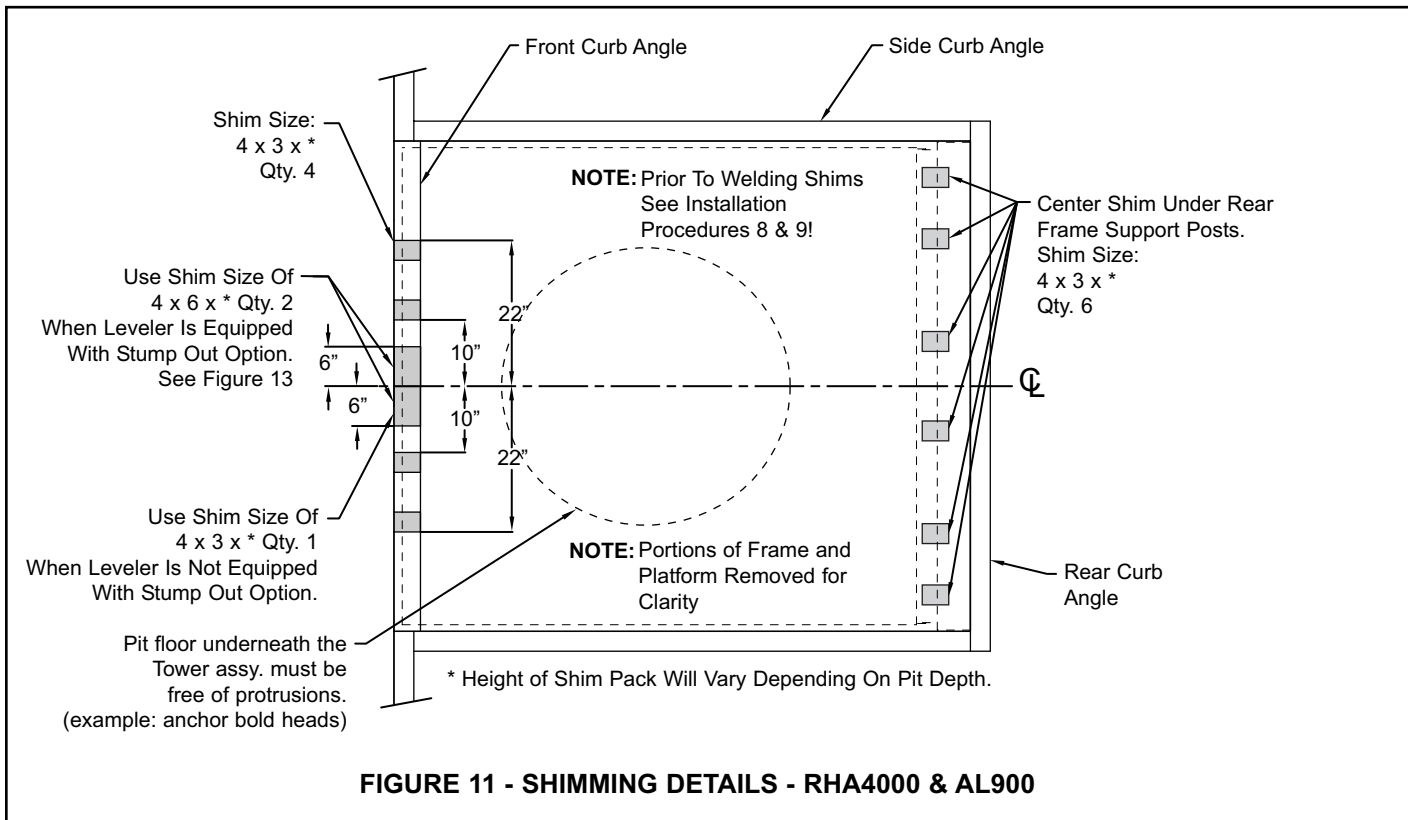

INSTALLATION INSTRUCTIONS CONT.

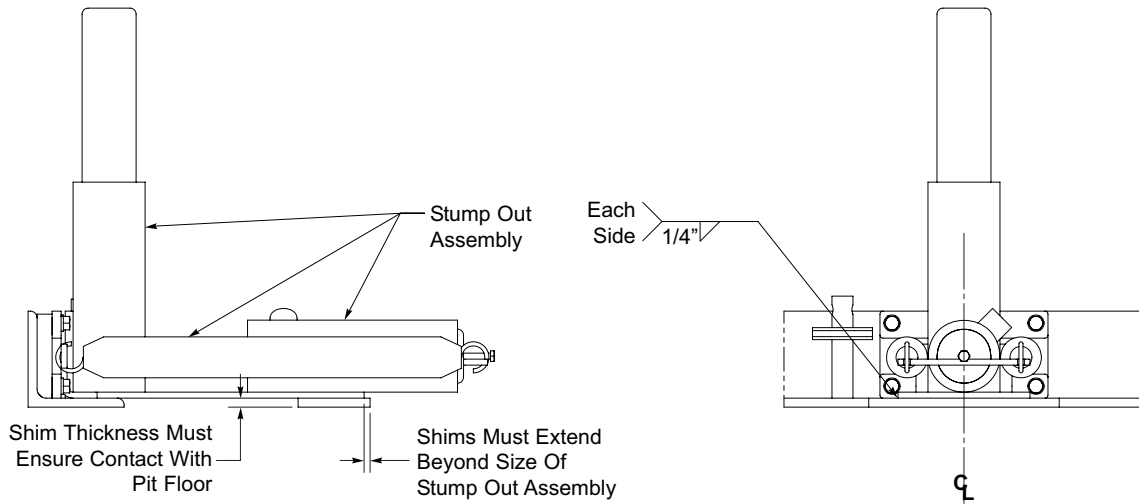

Stump Out Shimming Detail

NOTE: Shims are field installed

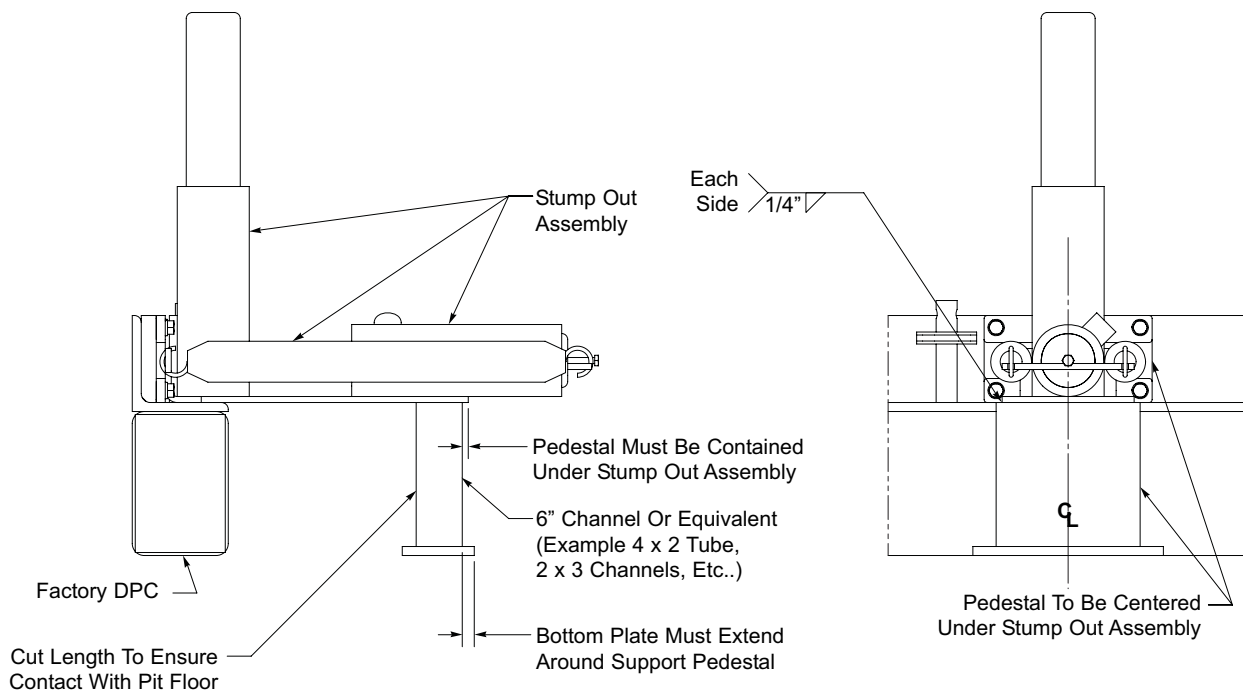

Stump Out Deep Pit Conversation Shimming Detail

FIGURE 13 - STUMP OUT ASSEMBLY SHIMMING DETAILS

INSTALLATION INSTRUCTIONS CONT.

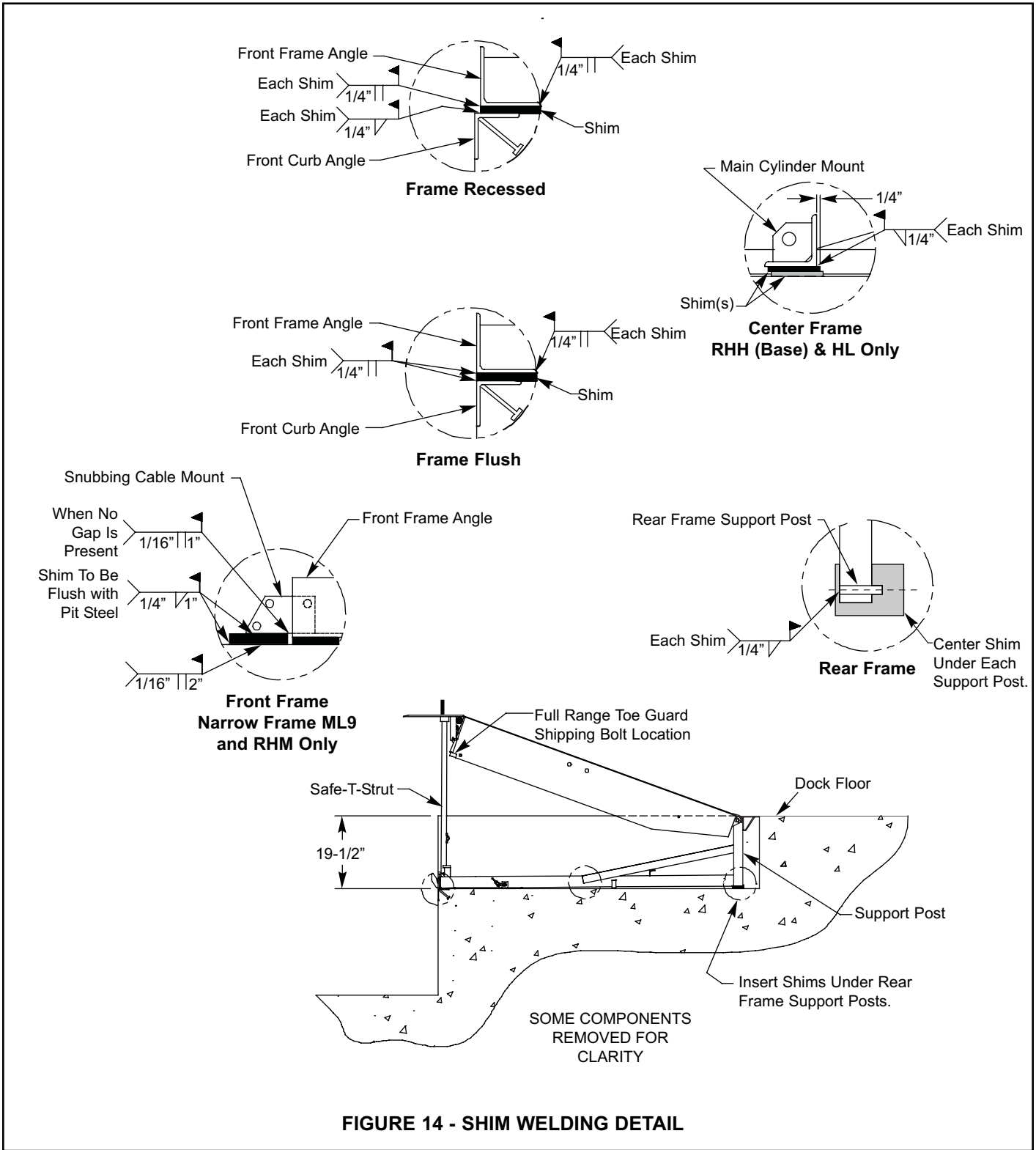

INSTALLATION INSTRUCTIONS CONT.

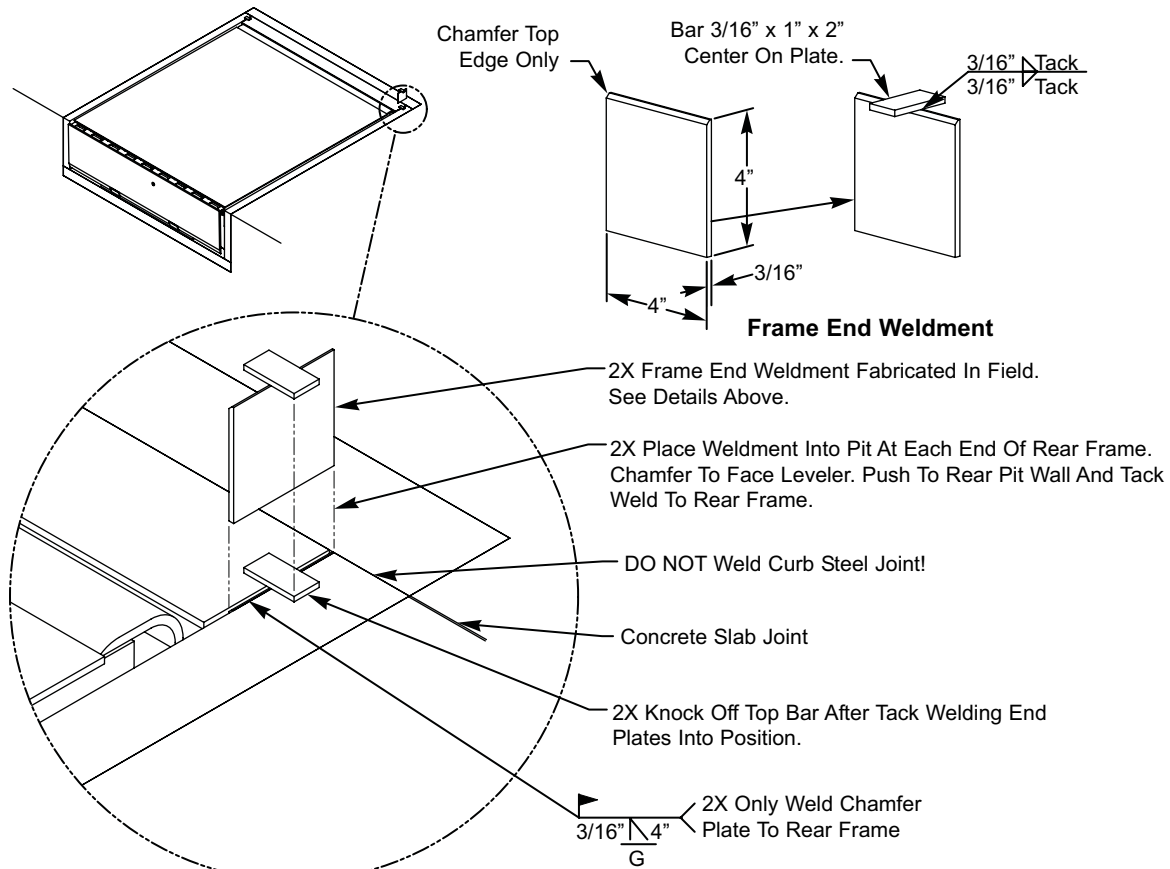

Instructions:

1. Fabricate frame end weldments prior to installation in field.
2. Apply welding clamp to leveler frame.
3. Remove paint from ends of rear frame.
4. Place frame end weldment into pit at each end of rear frame. Chamfer to face leveler. Push to rear pit wall and tack weld to rear frame.
5. Knock off top bar after tack welding end plates into position.
6. Only weld chamfered plate to rear frame. DO NOT weld to side pit steel.
7. Remove weld debris and grind welds smooth.
8. Apply touch up paint to all weld and grind areas.

NOTE: If Leveler can be accessed prior to being installed into pit, plates can be welded to end of frame prior to dropping into pit.

FIGURE 15 - ALTERNATIVE INSTALLATION FOR SHRINK COMPENSTATED FLOOR

INSTALLATION INSTRUCTIONS CONT.

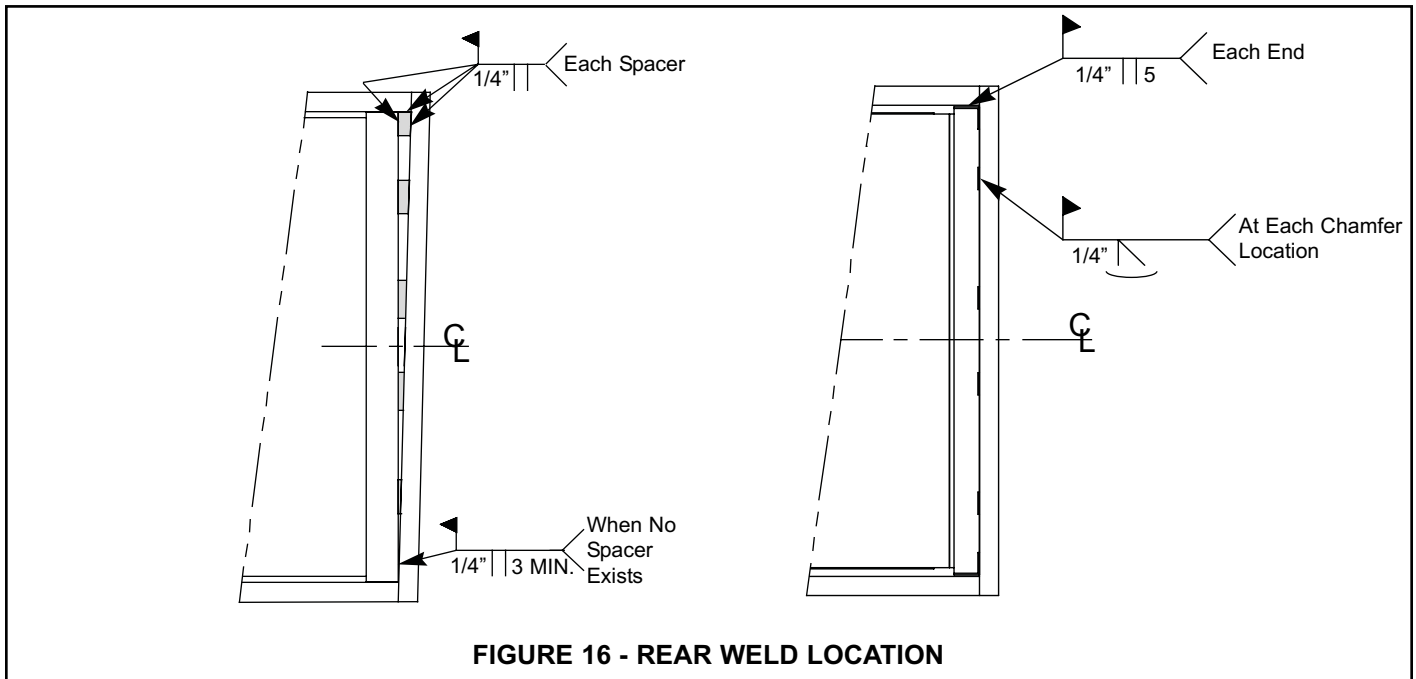

FIGURE 16 - REAR WELD LOCATION

13. Check to insure leveler is still centered and level in pit before final welding.
14. Weld rear frame to curb steel at chamfered locations at back edge of rear frame angle. See figure 16.
15. Weld front frame angle to the front curb angle. See figure 14.
16. Clean and paint all weld and grind marks.
17. **RHA & AL Series Only:** Place Air Tower Tub into leveler frame correctly. See figure 17.
18. **RHA & AL Series Only:** Insert platform attachment rods on each side of the Air Tower. Manually raise left side of the Air Tower and secure to J-hooks on platform stringer.
19. **RHA & AL Series Only:** Raise right side of the Air Tower and ensure platform attachment rod is on top of the stringer anchor loops. Secure a S-hooks around each anchor loop and the platform attachment rod.
21. **RHA & AL Series Only:** Plug blower motor into pit outlet.
21. Remove front shipping bolts from each Toe guard if leveler is equipped with toe guards. Verify toe guards move up and down freely.

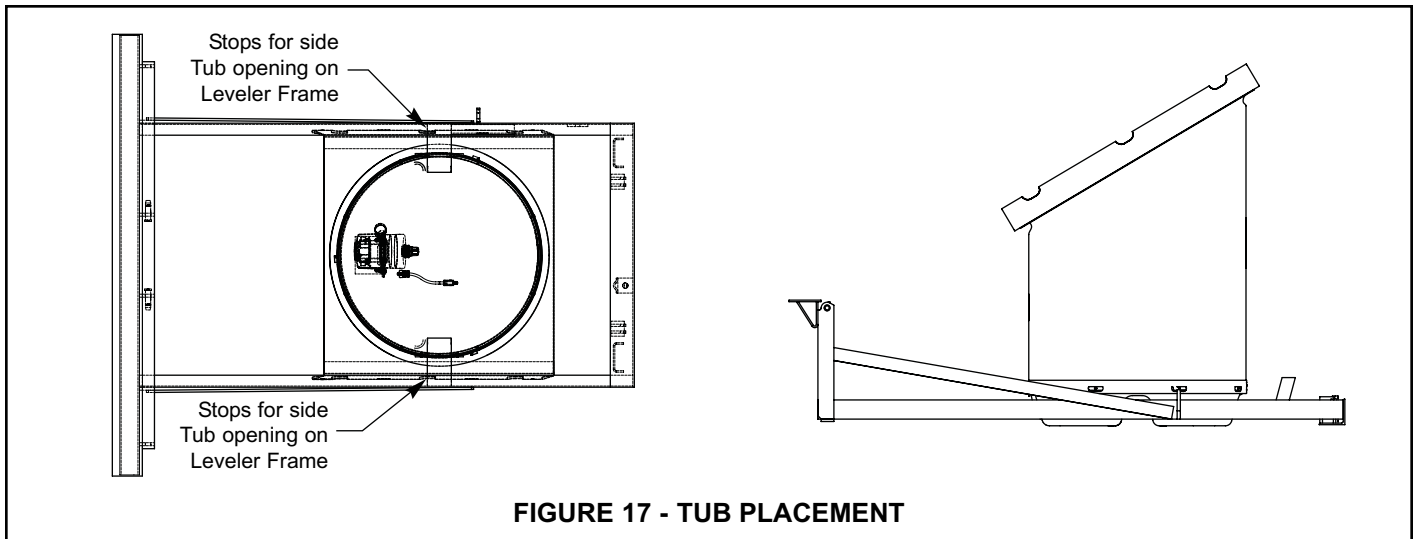

FIGURE 17 - TUB PLACEMENT

INSTALLATION INSTRUCTIONS CONT.

21. Complete Bumper and Lip Support installation procedures found in this manual. See pages 17 and 18.
22. Verify Lip Stop Bolt adjustment. See figure 19.
23. Lubricate leveler.
24. **Mechanical leveler:** Mount inside operation sign and operate leveler several times and verify proper operation. Adjustments may be needed to insure proper operation. Adjust as needed. Reference Owners Manual for proper operation and adjustments.

Powered leveler: Complete electrical installation. operate leveler several times to verify proper operation. Adjustments may be needed to insure proper operation. Adjust as needed. Reference Owners Manual for proper operation and adjustments.

Control Box installation guidelines - Temperature controlled applications.

- a. Conduit should be routed to enter through the bottom or side of the enclosure. A drip leg may be needed if the conduit could fill with water.
- b. Seal the conduit in any location where the conduit transitions temperature zones that may produce condensation.
- c. Spacers should be installed between the enclosure and the wall to provide tempature insulation and air flow.

LEVELER ADJUSTMENTS

LIP LATCH BOLT ADJUSTMENT (RHA & AL ONLY)

The lip latch bolt is factory adjusted. If the lip does NOT latch when the leveler is fully raised and remain latched as the platform lowers, the lip latch bolt may need to be readjusted. Use the following procedure to readjust the lip latch bolt: See figure 18.

1. Loosen the jam nuts on the lip latch bolt.
2. Turn the bolt clockwise one full turn at a time.
3. Tighten the jam nuts on the lip latch bolt.
4. Follow normal operating procedures to verify that the lip latch has been adjusted correctly and holds the lip out as the platform lowers. Test unit three times to make sure it latches all three times, if not readjust.

NOTE: DO NOT over adjust the lip latch bolt. When properly adjusted the lip should just latch in. If you have over adjusted the lip may not release, or it will bend the delatch rod over time. Re-adjust bolt until lip no longer latches and then make one full turn of the bolt until lip just latches.

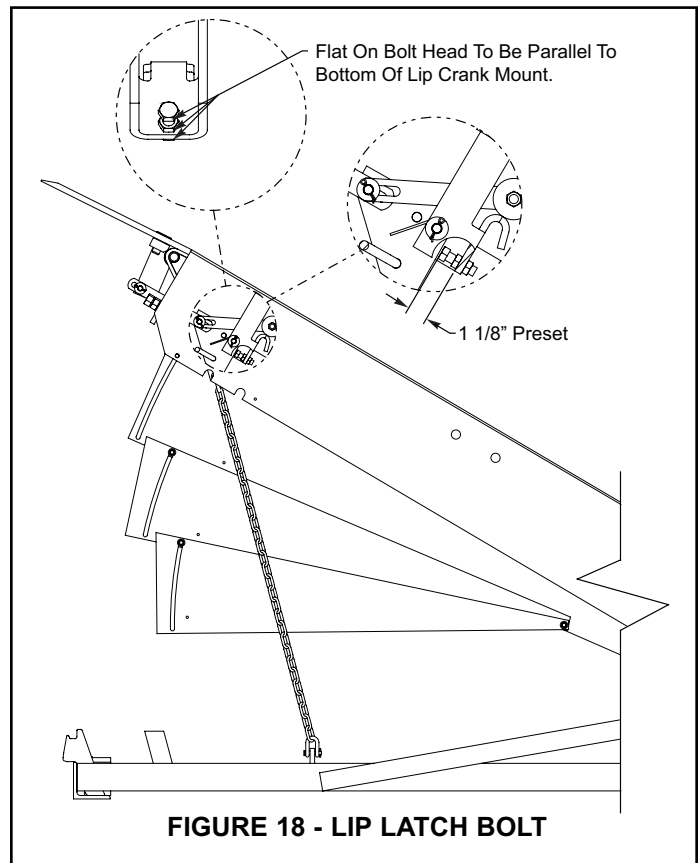

FIGURE 18 - LIP LATCH BOLT

LIP STOP BOLT ADJUSTMENT (ALL UNITS)

The lip stop bolt adjusts the position of the lip when the leveler is stored to allow the lip to be centered on lip supports when stored.

NOTE: Lip stop bolt will need to be adjusted on longer lips to allow lip to be centered in the lip keepers.

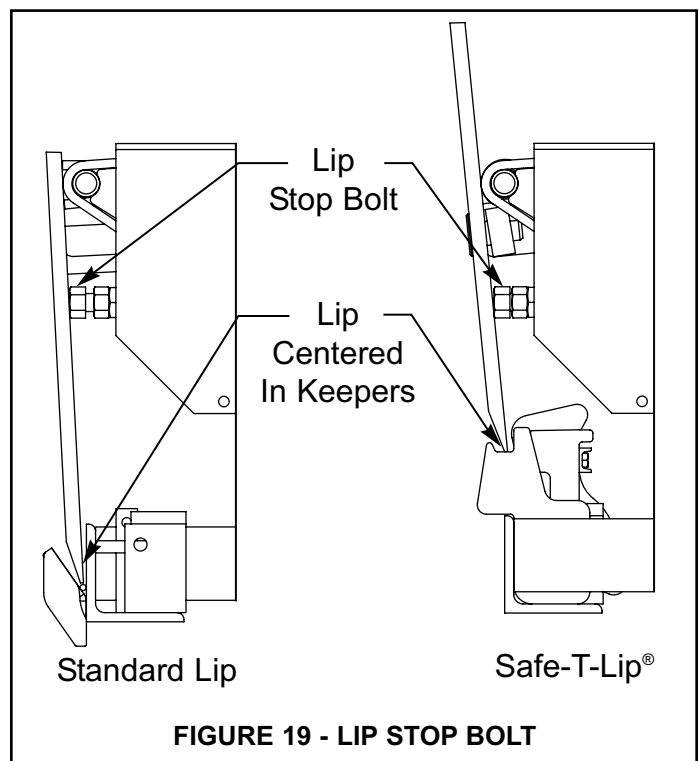
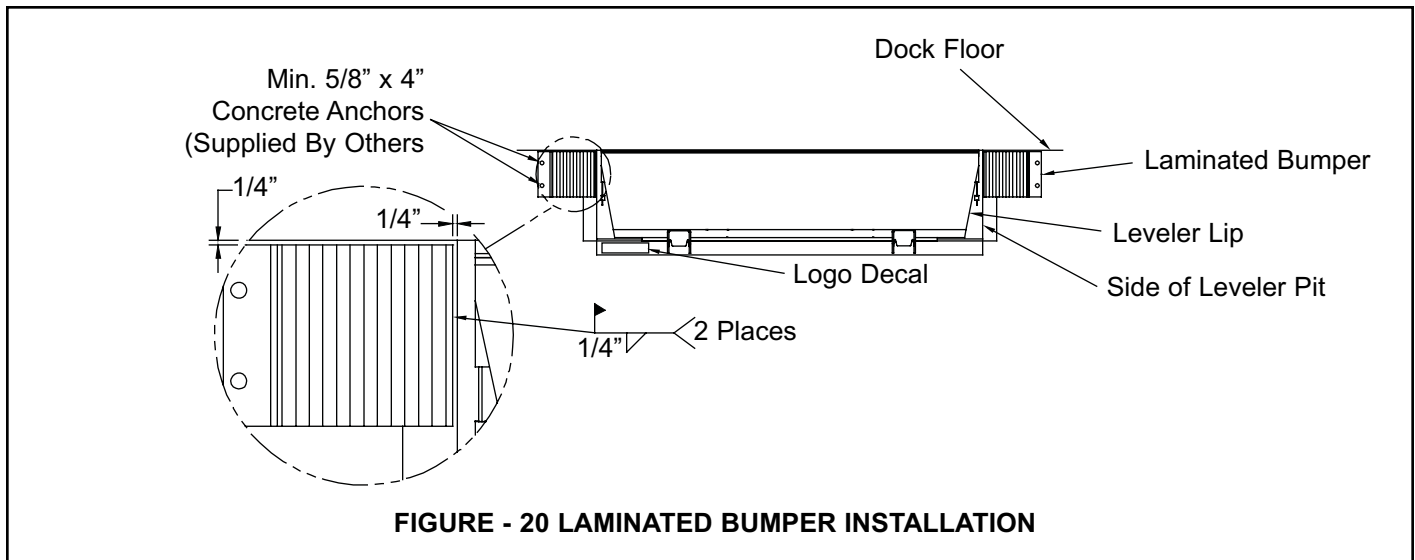

FIGURE 19 - LIP STOP BOLT

BUMPER INSTALLATION

LAMINATED BUMPER INSTALLATION (Standard)

1. Tack weld each bumper in position as shown in figure 20.
2. Each bumper should be secured with two 5/8 inch concrete anchor bolts that are a minimum of 4 inch long. (Ref. Rawl anchor 6942 - supplied by others.)
3. Using bumper mounting holes as a guide drill two 5/8 inch holes per bumper that are approximately 1/2 inch deeper than the bolt length that will be used.
4. Secure other end of each bumper with concrete anchor bolts. Torque each bolt to 120 ft-lbs.
5. Weld the bumper side plate to the front vertical pit angle.
6. Clean and paint all weld and grind marks.
7. Apply logo decal to front curb angle. See Figure 20.



NOTE: RHH, HL, RHA and AL Dock Levelers

It is suggested to add two installation tabs just behind the lip to support the leveler platform even and flush with the dock floor before lip support installation. See Figure 21.

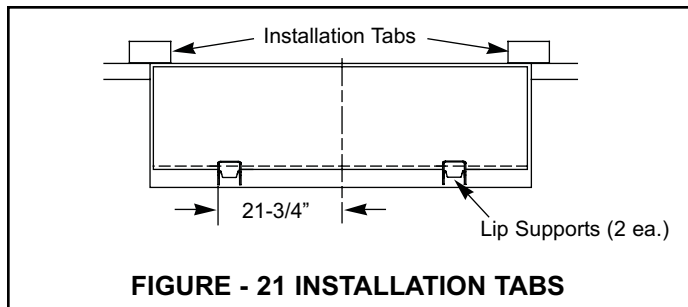

FIGURE - 21 INSTALLATION TABS

1. Place marks 21-3/4" out from pit centerline on front pit angle. See Figure 21.
2. On levelers with lips greater than 20" install lip keeper mounting plate. See Figure 23.
3. Locate the centerline of the lip support assemblies.
4. Remove maintenance support and lower the leveler until it is flush with dock level and lip is fully pendant.
5. Position lip support assemblies along the edge of the lip and mark the bottom of lip support on front pit angle.
6. Fully weld along the lip support and front pit angle. See Figure 22.

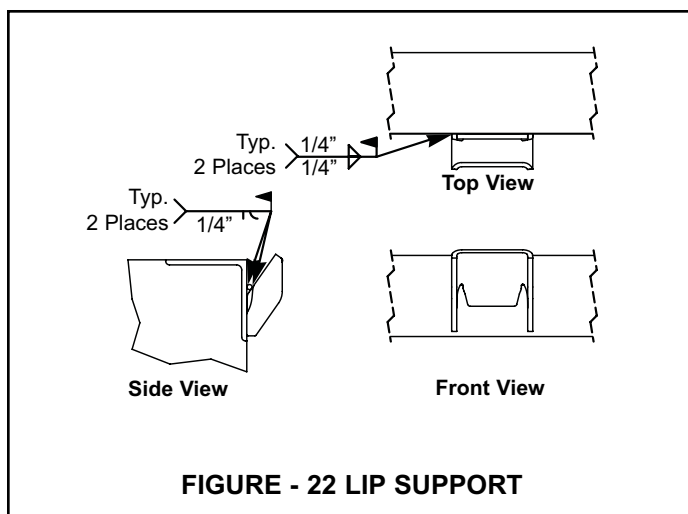
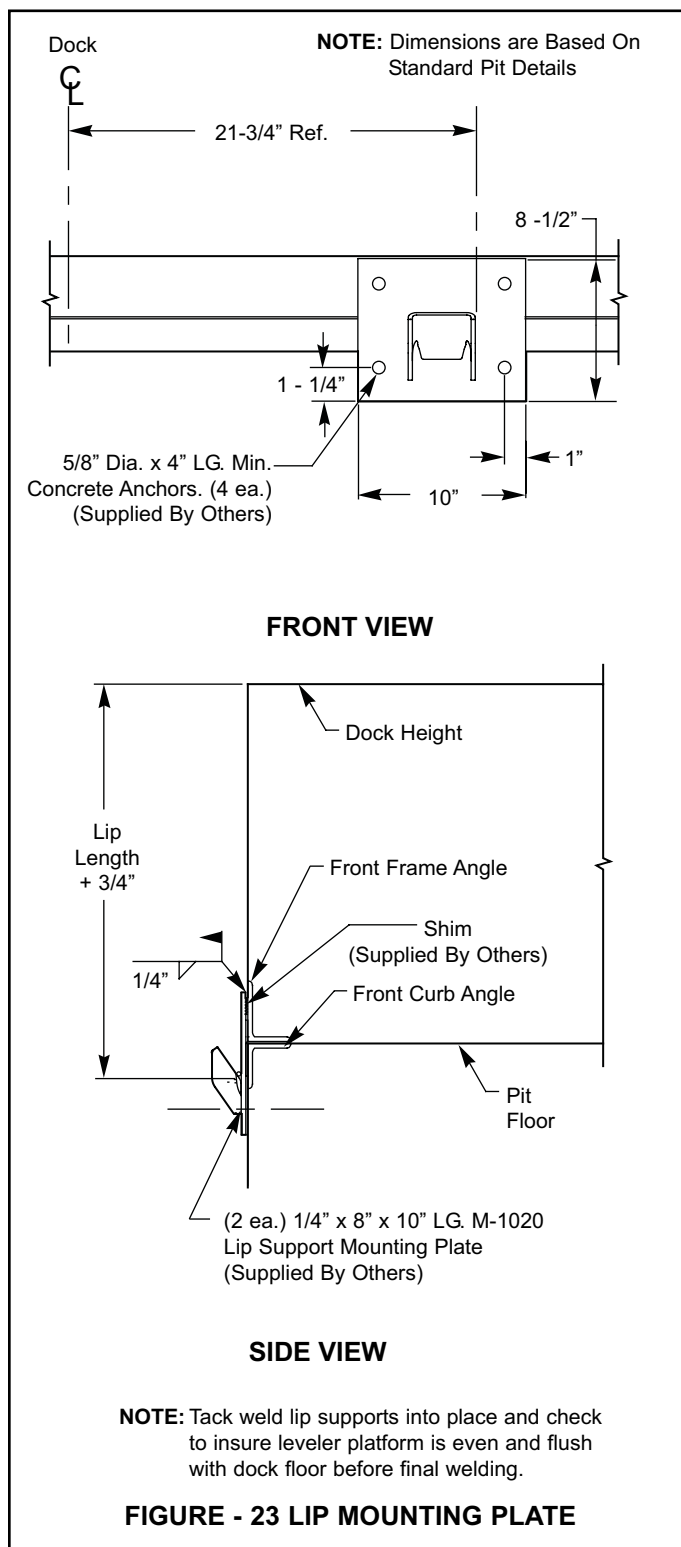

FIGURE - 22 LIP SUPPORT

7. Repeat the procedure for the second lip support assembly.
8. Clean and paint all weld and grind marks.

LIP SUPPORT INSTALLATION



TYPICAL COMPLETE INSTALLATION

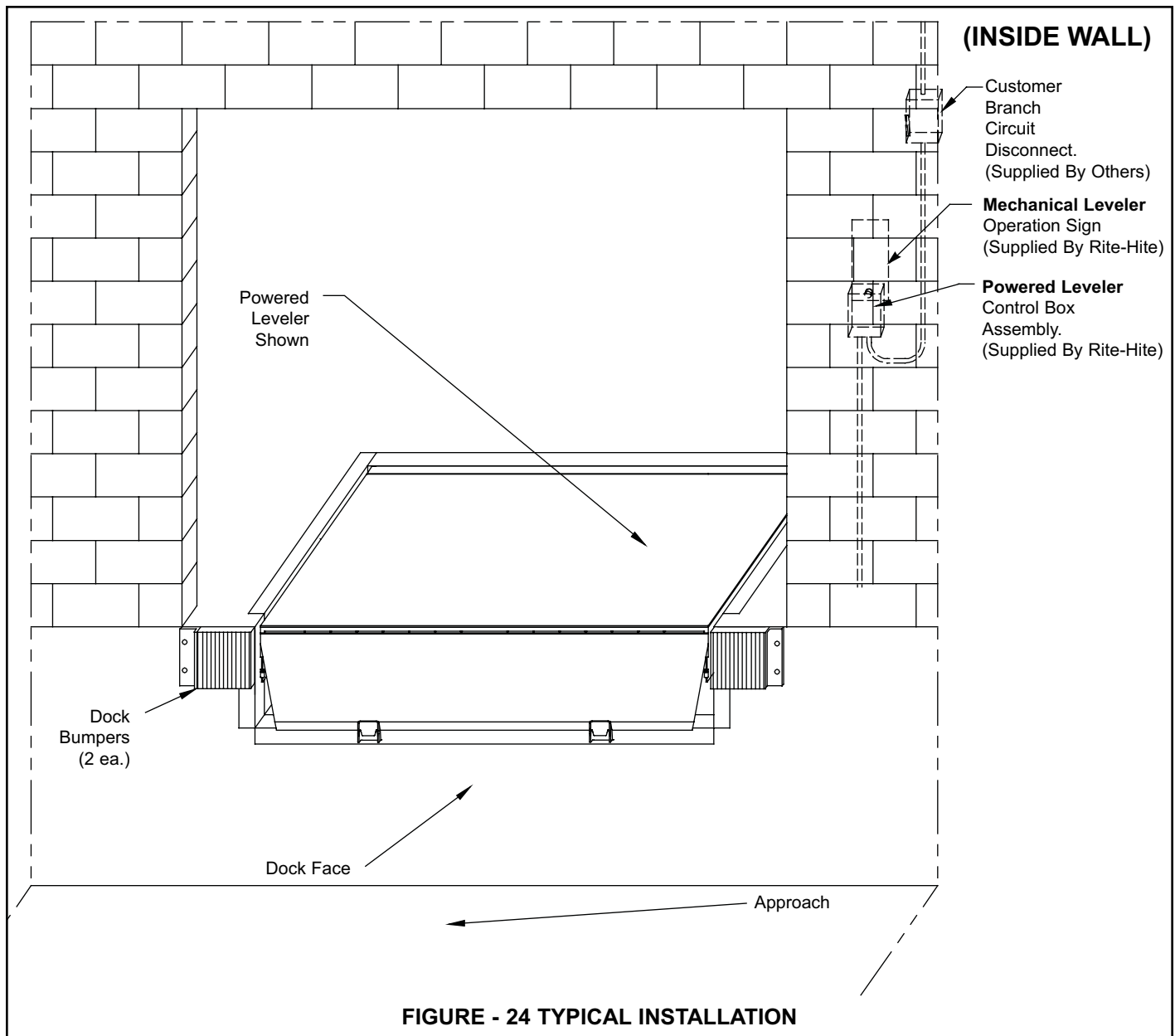

NOTES

NOTES

GENISYS WARRANTY

Genisys Dock Leveler by Rite-Hite®
Standard Warranty Policy

Rite-Hite® warrants to and for the sole benefit of the original purchaser that Genisys by Rite-Hite® (hereinafter "Genisys") Dock Levelers shall be free from defects in material and workmanship subject to the following:

Length of Time: All products are warranted for a one year period commencing on the earlier date of approved installation or the (30th) day after the date of shipment. This warranty covers the repair or replacement of the defective product or component at Rite-Hite's sole election and expense, including reasonable labor, reasonable travel and freight.

Component Scope: The structural components protected by this warranty include the rear frame, deck, lip, front and rear hinge area and working range toe guards on all Genisys Dock Levelers.

- On HL Series dock levelers, all cylinders, pumps, hoses, fittings, electrical motors and control panels are covered.
- On ML Series mechanical levelers, springs, chains, lip extension mechanism, main counterbalance and ramp control are covered.
- On AL Series dock levelers, air tower assy., lip extension mechanism, chains and control panels are covered.
With an additional 5 year warranty on the air tower assy.

Repair part freight costs will be borne by Rite-Hite® via standard shipping terms. Charges for overnight or special freight requirements will be billed to the end user, General Contractor or Genisys Representative and must be approved at time of shipment.

Warranty claims will not be accepted if the parts and/or assemblies have not been installed on Genisys products or the installation has not been carried out in accordance with Genisys installation instructions.

If a part is replaced during the standard warranty period, it will be covered for the remainder of the warranty period for the dock leveler.

The above warranties are in lieu of any other warranties, either expressed or implied, including but not limited to any warranty of merchantability or implied warranty of fitness for a particular application.

In no event shall Rite-Hite® or any of its subsidiaries be responsible for or liable to anyone, including third parties, for special, indirect, punitive, incidental or consequential damages, even if Rite-Hite® Representative has been advised of the possibility of such damages. Such excluded damages include, but are not limited to, loss of goodwill, loss of profits, loss of use, interruption of business, or other similar indirect financial loss.

This limited warranty shall be void and of no effect:

- if product is altered or modified from its original condition as installed or as delivered at or from the factory
- to the extent that the product defect is the direct result of improper installation, operation beyond capacity, or other than in accordance with Genisys instructions, careless or negligent use, or failure to maintain the product as recommended by the Genisys owner's manual.
- if Rite-Hite® or the Genisys Representative is not notified of the defect and such notification failure creates additional component or product stress which compounds the cost for defect correction.
- if the product is not adjusted and lubricated on the intervals and to the extent required in the Genisys Owner's Manual.
- if the product is moved and reinstalled from its original installation point without advising Rite-Hite® or a Rite-Hite® Representative.



RITE-HITE® STANDARD WARRANTY

RITE-HITE® warrants that its products will be free from defects in design, materials, and workmanship for a period of 365 days from the date of shipment. All claims for breach of this warranty must be made within 30 days after the defect is or can, with reasonable care, be detected and in no event no more than 30 days after the warranty has expired. In order to be entitled to the benefits of this warranty, the products must have been properly installed, maintained, and operated within their rated capacities and/or specified design parameters, and not otherwise abused. Periodic lubrication and adjustment is the sole responsibility of the owner. This warranty is RITE-HITE's® exclusive warranty. RITE-HITE® EXPRESSLY DISCLAIMS ALL IMPLIED WARRANTIES, INCLUDING THE IMPLIED WARRANTIES OF MERCHANTABILITY AND FITNESS. Non-standard warranties, if any, must be specified by RITE-HITE® in writing.

In the event of any defects covered by this warranty, RITE-HITE® will remedy such defects by repairing or replacing any defective equipment or parts, bearing all the costs for parts, labor, and transportation. This shall be the exclusive remedy for all claims whether based on contract, negligence, or strict liability.

LIMITATION OF LIABILITY

RITE-HITE® SHALL NOT IN ANY EVENT BE LIABLE FOR ANY LOSS OF USE OF ANY EQUIPMENT OR INCIDENTAL OR CONSEQUENTIAL DAMAGES OF ANY KIND, WHETHER FOR BREACH OF WARRANTY, NEGLIGENCE, OR STRICT LIABILITY.



Global Sales & Service Office:

**RITE-HITE®
8900 N. Arbon Drive
P.O. Box 245020
Milwaukee, Wisconsin 53224**

**Phone: 414-355-2600
1-800-456-0600
www.ritehite.com**

Representatives in all Major Cities