

4

3

2

1

NEXT ASSEMBLY

REVISION HISTORY					
REV	DESCRIPTION	ECH	DATE	BY	APPROVED
A	ADDED NOTE ABOUT RAISED BUMPERS	08-009	3/26/08	GDB	
B	ADDED "FOR REFERENCE ONLY" NOTE	11-010	3/29/2011	GDB	

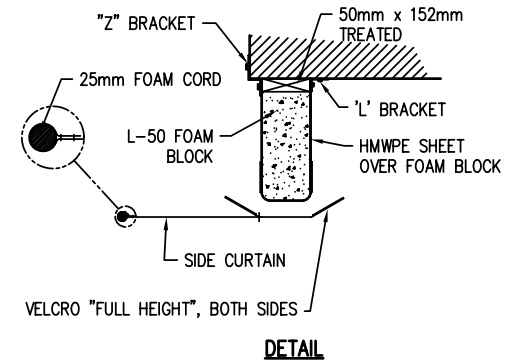
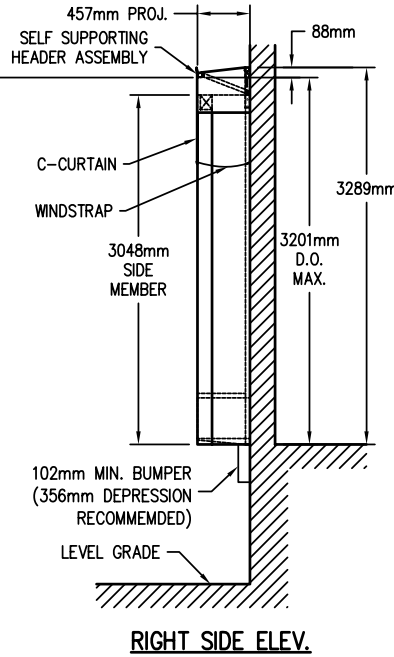
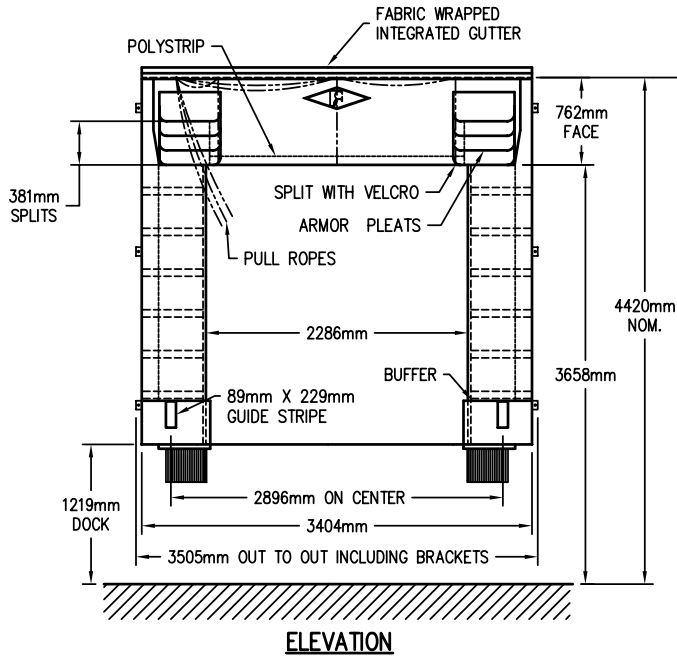

C STYLE CURTAIN: F114 22 PLUS, BLACK
 SIDE FRAME: F114 22 PLUS, BLACK
 SIDE CURTAIN: F114 22 PLUS, BLACK
 RECOMMENDED TRUCK COVERAGE: 3810mm - 4115mm HIGH
 X 2438mm - 2591 WIDE

NOTE:
 APPLICATIONS THAT HAVE BUMPERS MOUNTED ABOVE DOCK HEIGHT (OR ABOVE THE PIT FLOOR IN VERTICAL LEVELER APPLICATIONS) MAY REQUIRE THAT THE BOTTOM OF THE SIDE MEMBERS BE MOUNTED AT THE TOP OF THE BUMPERS INSTEAD OF AT DOCK HEIGHT.

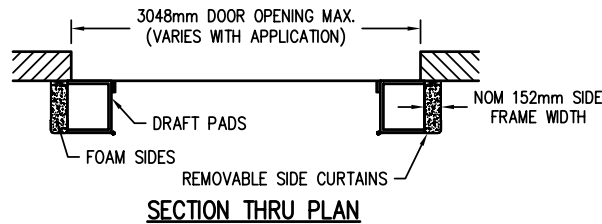

THIS DRAWING IS FOR REFERENCE ONLY. DO NOT USE FOR PRODUCTION PURPOSES.

©2002 FROMMELT PRODUCTS CORP.

INCH TOLERANCES			DO NOT SCALE DRAWING	
OVER	UP TO	+ / -	MM-DD-YY	DATE
0	0.125	0.005	MM-DD-YY	DATE
0.125	0.25	0.010	DRAWN BY	8/24/07
0.25	1.25	0.020	CHECKED BY	DATE
1.25	5	0.030	APPROVED BY	DATE
5	15	0.040	INITIAL ECH	
15	40	0.050	DATE ISSUED	
40	80	0.100	REF	
80	-	0.125		

ITEM	QTY	PART NO.	DESCRIPTION
PARTS LIST / MATERIAL			
FROMMELT PRODUCTS CORP.			
ARCHITECTURAL APPROVAL (METRIC) 610E SERIES SHELTER ELIMINATOR II - 152mm BACKER			
SIZE	MODEL NUMBER	DWG NO	REV
C	610E	A7120090	B
SCALE 3/8"=1'		PART #	SHEET 1 of 1

4

3

2

1

DWG NO A7120090 SHEET 1 of 1 REV B