

# Frommelt® ELIMINATOR™ II- COMBOSHELTER™ II

610 Series

## Installation Instructions & Owner's Manual

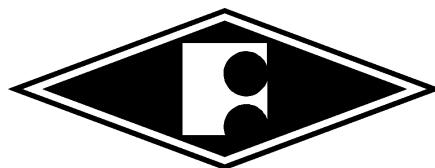
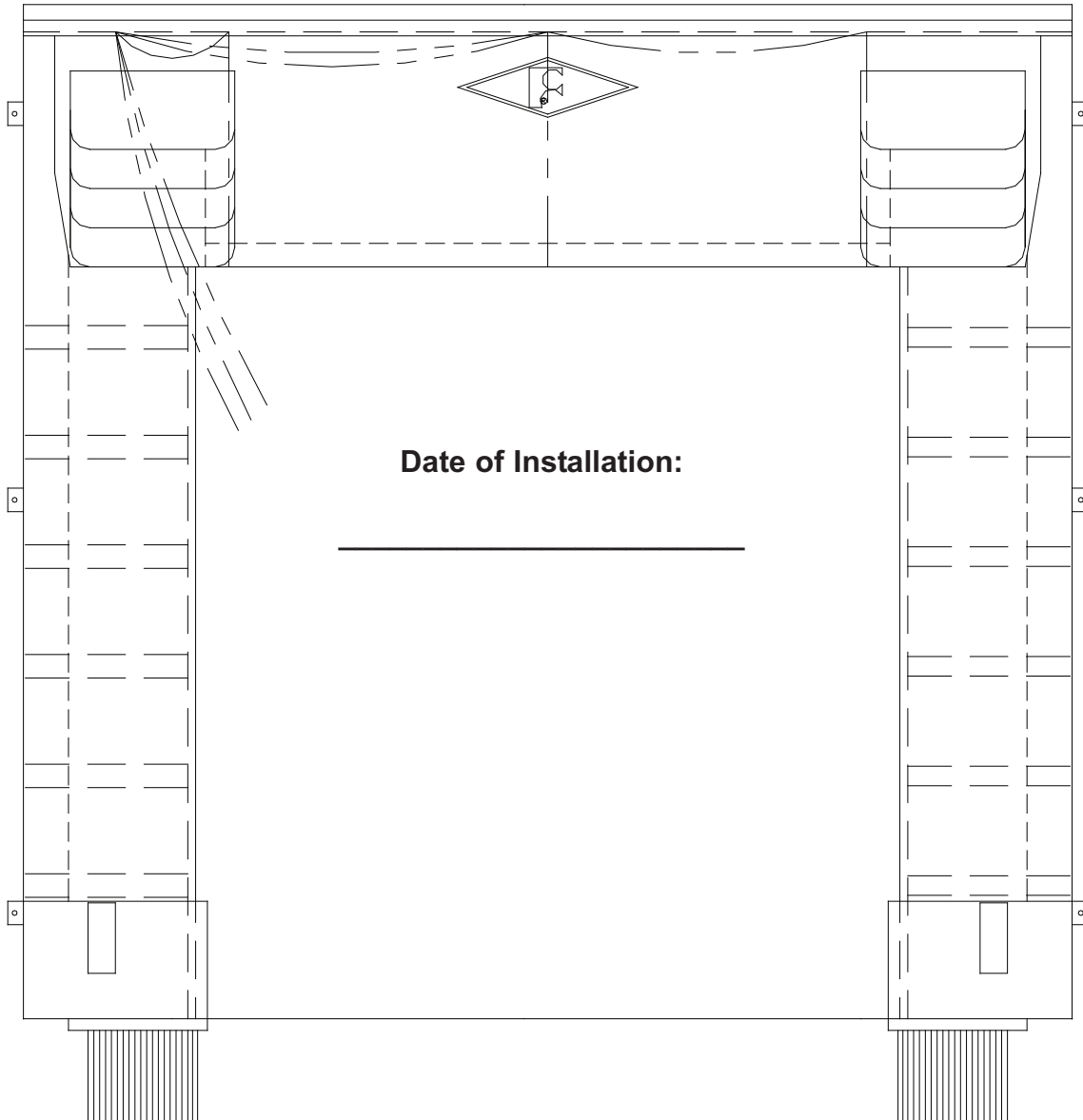

This Manual Covers All Units Shipped 4/10 to Date

# WARRANTY POLICY

---

Frommelt warrants that an **Eliminator™ II or ComboShelter™ II 610 Series** will be free of defects in design, materials, and workmanship for a period of 365 days from the date of shipment. All claims for breach of this warranty must be made within 30 days after the defect is or can, with reasonable care, be detected and in no event more than 395 days after shipment. In order to be entitled to the benefits of this warranty, the product must have been properly installed, maintained, operated within its rated capacity, and not otherwise abused.

**Frommelt expressly disclaims all implied warranties including the implied warranties of merchantability and fitness.**

In the event of any defects covered by this warranty, Frommelt will remedy such defects by repairing or replacing any defective parts, bearing only the cost of the parts and transportation of those parts. This shall be the exclusive remedy for all claims whether based on contracts, negligence, or strict liability.

**Frommelt shall not in any event be liable for any loss of use of any equipment or incidental or consequential damages of any kind.**

---

**“Our mission is to improve industrial safety and productivity worldwide through quality and innovation.”**

---

Frommelt® Products Corporation  
A Rite-Hite Company  
8900 North Arbon Drive  
P.O. Box 245020  
Milwaukee, WI 53224-9520

# TABLE OF CONTENTS

---

The following installation instructions are a compilation of the various components needed to comprise an Eliminator™ II or ComboShelter™ II model. There may be some components included in these instructions that do not apply to the unit being installed. Below is a guide to the various components included.

---

<b><u>Section</u></b>	<b><u>Section/Page</u></b>	<b><u>Publication No.</u></b>	<b><u>Rev.</u></b>
Cover	A1	ECII 610	D
Warranty Statement	A2	ECII 610	D
Table of Contents	A3	ECII 610	D
Order of Installation	A4	ECII 610	D
Exploded View	A5	ECII 610	D
Quality Check List	B1	ECII 610	D
Model, Eliminator™	C1	610E-0003	B
Side Frame	D1	5656-0007	C
Side Curtain	E1	2860-0003	None
Canopy Style Header	F1	1610-0003	C
C Style Face Curtain	G1	2861-0002	A
C4 Style Face Curtain	H1	2862-0002	C
Gutter Assembly	I1	5162-0004	A
“610 Series” Bumper	J1	1531-0003	None
Draft Pad	K1	4109-0004	A
Options inserted as required:			
Header Blockouts	L		
Side Frame Blockouts	L		
Foam Backers	L (Not used on Combo II)		
Foam Backer Blockouts	L (Not used on Combo II)		

# ORDER OF INSTALLATION

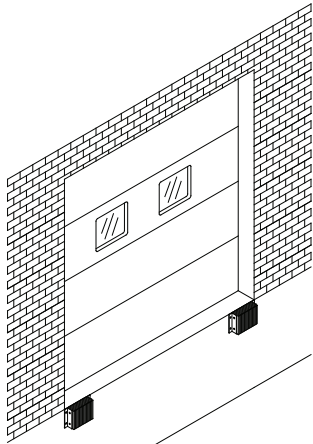

STEP #1  
PREPARE UNIT

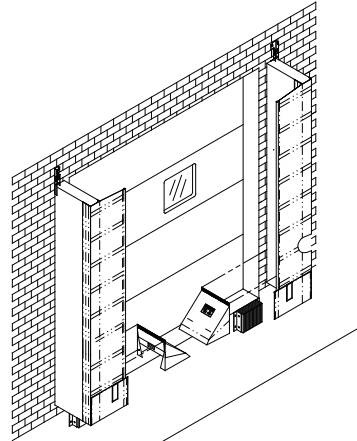

STEP #4  
INSTALL DRAFT PADS

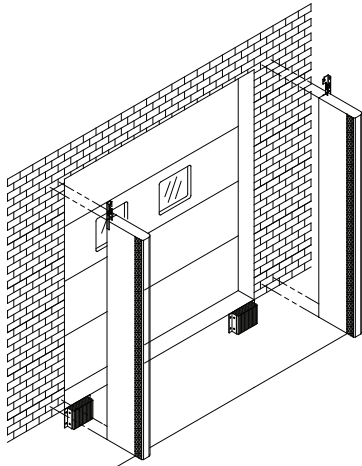

STEP #2  
INSTALL SIDE MEMBERS

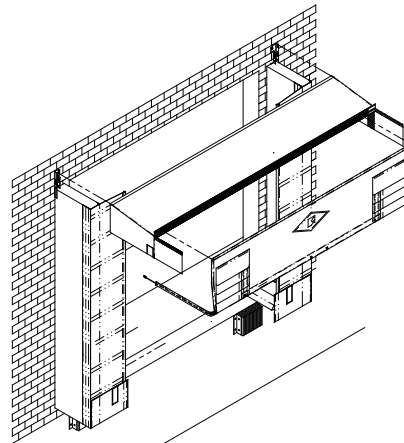

STEP #5  
INSTALL CANOPY HEADER &  
C STYLE CURTAIN

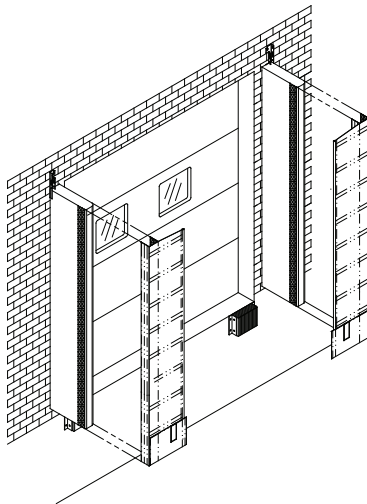

STEP #3  
INSTALL SIDE CURTAINS

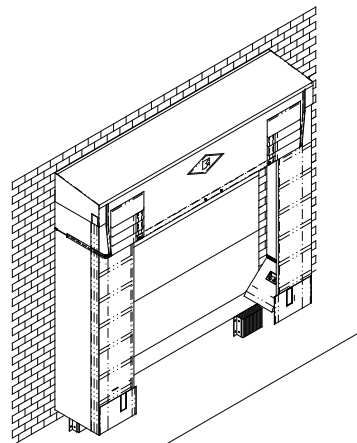

STEP #6  
INSTALL ALL OTHER OPTIONS  
(METAL HOODS, BOTTOM PADS, ETC...)

# EXPLODED VIEW

This unit shown in exploded view is a standard Eliminator™ II. Your unit may have options which are not shown in the exploded view, depending on options chosen, and application of the unit.

- |                                     |   |
|-------------------------------------|---|
| 1 Bottom Pad, Left                  | 17 Screw, HWH,Slf Dr/Tap, 12-14 x ¾     |
| 2 Cap, Vinyl, Scotch-Ply Stay       | 18 SCR,HWHSMS, #14X1-1/4, ZNC           |
| 3 Stay, Scotch-Ply, Side Curtain    | 19 Lumber, Header, 2X4                  |
| 4 Side Curtain, Left                | 20 Cover, Canopy                        |
| 5 Cover, Side Frame, Left           | 21 Bracket, Mounting, Header, Right     |
| 6 Sheet, HMWPE                      | 22 Frame, Top                           |
| 7 Foam, Side Frame                  | 23 Assembly, Ring, Pull Rope            |
| 8 Brackets, "L"                     | 24 Screw, HWH,Slf Dr/Tap, 1/4-14X1-1/4" |
| 9 Nail, Roofing                     | 25 Washer, Fender, .25"IDX1.5"OD        |
| 10 Lumber, Side Frame, 2X6          | 26 Curtain, Face, C or C4 Style         |
| 11 Bolt, "U", Safety                | 27 Strip, Poly, 1/4                     |
| 12 Pin, Clevis, 3/8"X2"             | 28 Assembly, Gutter Plate               |
| 13 Bracket, Mounting, Header, Left  | 29 Brackets, "Z"                        |
| 14 Clip,BridgePin,3/8"-7/16"X.0915W | 30 Cover, Side Frame, Right             |
| 15 Nut, "U", Safety Bolt            | 31 Side Curtain, Right                  |
| 16 Windstrap, C Style Curtain       | 32 Bottom Pad, Right                    |

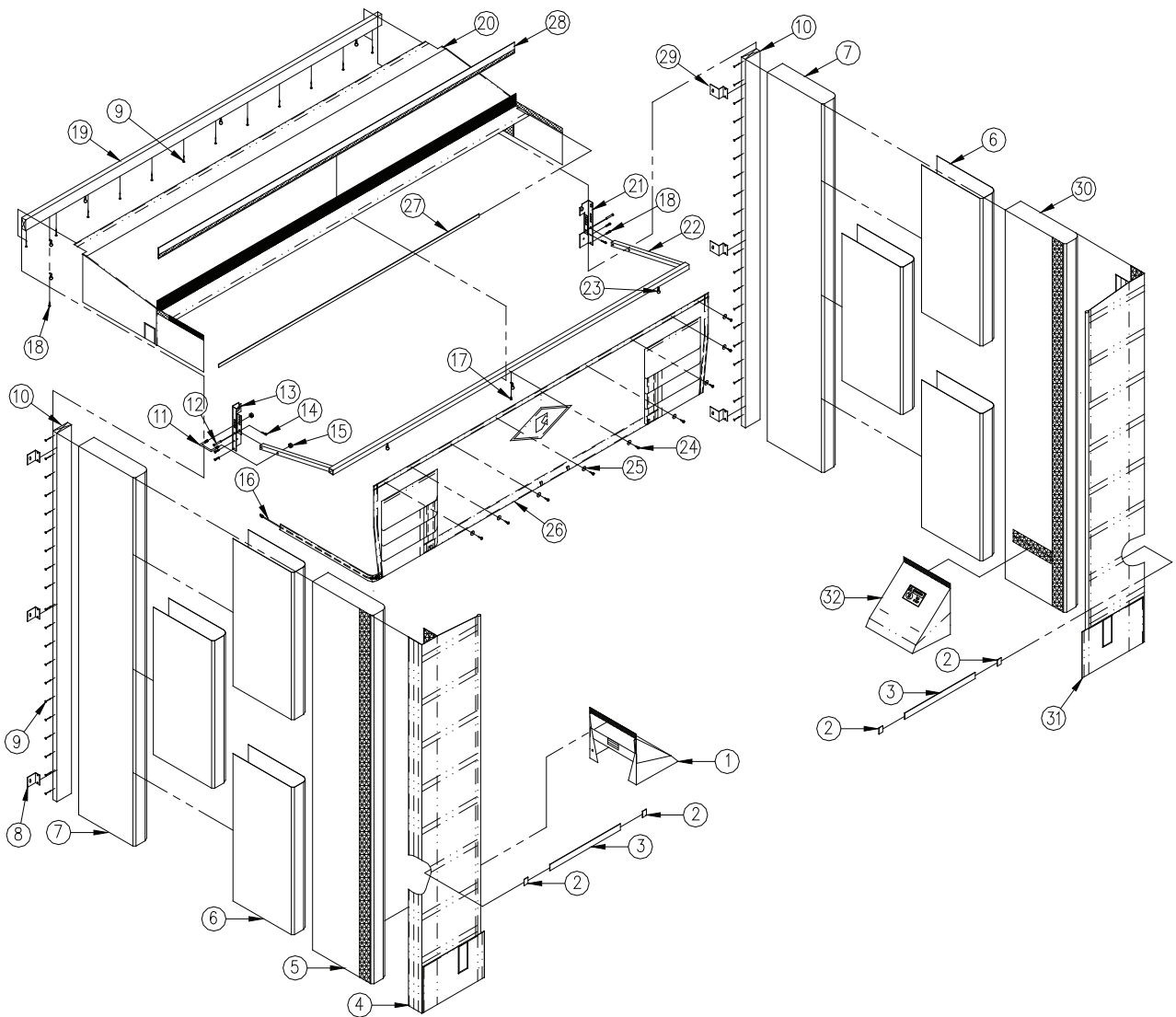

# 610 Series Eliminator™ II & Combo™ II Quality Check List

- Model, Eliminator™ II [610E-0003] \*
- Model, Combo™ II       Drive Thru

- Side Member [5656-0007]
  - Standard
  - Tapered
  - Common
  - Side Member Blockouts (wood) [1321-0008]
  - 4" Side Frame Width
  - Other: \_\_\_\_\_

- Side Curtain [2860-0003]
  - Standard
  - Common
  - Other: \_\_\_\_\_

- Canopy Style Header [1610-0003]
  - Standard
  - Flat Pitch "Over Sides"
  - Integral Hood
  - Common Member

- C Style Face Curtain [2861-0002]
  - Standard
  - Firefighter™
  - C-Curtain Blockouts [1322-0009]
  - Secondary Pull Ropes
  - 3" Foam Front
    - Full
    - Split
    - Partial
  - C Style Curtain Weights
  - Other: \_\_\_\_\_

- Windstraps  
Length: \_\_\_\_\_

- C4 Style Face Curtain [2862-0002]
  - Standard Pitch
  - C4 Pull Ropes
  - C4 Weight Pockets
  - C-Curtain Blockouts [1322-0009]
  - Other: \_\_\_\_\_

- Collapsible Draft Pads [4108-0004]

- Options
  - 18" Foam Backer [7632-0003]
    - Foam Backer Blockout [1323-0007]
  - Full Width Foam Backer [7632-0003]
    - Foam Backer Blockout [1323-0007]
  - 610 Series Bumpers [1531-0002]
  - Other: \_\_\_\_\_
  - Other: \_\_\_\_\_
  - Other: \_\_\_\_\_

\* **Note:** Installation Instruction part numbers are shown in italics. If a component or option is checked off on this sheet and it has a part number in brackets, those instructions must ship with the unit. All units must ship out with the model installation instructions [610E-0003].

- Hardware Bags

- Canopy [53610158]
- Face Curtain [53610157]
  - C Style [53612002]
- Side Frame [53612006]
- Draft Pad [53610069]

- Brackets

- "L" Bracket \_\_\_\_\_
- Header (Qtys)
  - Std (L) \_\_\_\_\_ (R) \_\_\_\_\_
  - Flat (L) \_\_\_\_\_ (R) \_\_\_\_\_
  - Integral (L) \_\_\_\_\_ (R) \_\_\_\_\_
  - Common (L) \_\_\_\_\_ (R) \_\_\_\_\_
- "Drive Thru" Face Curtain Bracket
- Other: Fill out information below

RHC# _____	Brackets Sent: _____	Qty. _____	Hardware Bags Sent: _____	Qty. _____
No. of Units _____	_____	_____	_____	_____
Base Fabric: _____	_____	_____	_____	_____
Curtain Fabric: _____	_____	_____	_____	_____

Describe packaging type & number of shipping container:

\_\_\_\_\_

\_\_\_\_\_

\_\_\_\_\_

Comments:

\_\_\_\_\_

\_\_\_\_\_

\_\_\_\_\_

White - Installation Instructions

Yellow - Packing List

Pink - Attach to Original

File name: 610E-0002

FORM FILLED OUT SEPARATELY

---

---

# MODEL, ELIMINATOR™ II - COMBOSHELTER™ II

---

---

## Table of Contents

File Information	1
General Precautions	1
Introduction	1
Preparation	1
Illustrations	1
Installation Instructions	1
Care & Maintenance	1

## File Information

Document Name:	610E-0003
Date Last Revised:	03/30/10
Revision Letter:	B

## General Precautions

 **WARNING!!!**

**Post safety warning and barricade work area, at dock level and ground level to prevent unauthorized use of the dock position while service work is being performed.**

## Introduction

Thank you for purchasing a Frommelt® Eliminator™ II or ComboShelter™ II dock shelter. For other applications, please contact your local Rite-Hite® Sales Representative.

## Preparation

Remove all of the contents from the containers and check for damage. If any product shows signs of damage, contact Frommelt® Products Corporation, or your local sales representative.

## Illustrations

Illustrations for this document are contained on drawing #610E-0004

## Installation Instructions

This manual serves as a guide to the installation instructions that are attached. The factory will provide the appropriate installation instructions that the unit configuration requires. If the appropriate installation instructions have not been sent, any procedures for the installation of this dock seal have not been included in this manual, or instructions are not complete, contact:

**Frommelt Products Corporation**  
**A Rite-Hite Company**  
**8900 North Arbon Drive**  
**P.O. Box 245020**  
**Milwaukee, WI 53224-9520**

The following installation instructions have been attached:

<b>Component</b>	<b>Document#</b>
610 Series Side Frames	5656-0007
610 Series Side Curtain	2860-0003
Collapsible Style Draft Pad	4108-0001
Canopy Style Header	1610-0003
C-Style Curtain	2861-0002
C4-Style Curtain	2862-0002
Gutter Assembly	5162-0004
610 Series Bumper	1531-0002

### Optional Components

Additional installation instructions may be attached depending on the options chosen, and application of the unit.

## Care & Maintenance

Metal hoods are recommended for protection of seals and shelters against possible damage from rain, snow and ice on docks which do not have building projections and/or canopies.

Occasional cleaning of the seal or shelter is recommended. Use a low pressure hose, or damp cloth to wash unit.

# 610 SERIES SIDE FRAME

## Table of Contents

File Information . . . . .	D1
Introduction . . . . .	D1
General Precautions . . . . .	D1
Illustrations . . . . .	D1
Installation Instructions . . . . .	D1
Standard . . . . .	D1
Common Member . . . . .	D3
4" Side Frame Width . . . . .	D3
40" or Less Projection . . . . .	D3
Greater than 40" Projection . . . . .	D3
Fastening Methods . . . . .	D4
Bracketing Details . . . . .	D5

## File Information

Document Name:	5656-0007
Date Last Revised:	03/30/10
Revision Letter:	C

## General Precautions

### **WARNING!!!**

Post safety warning and barricade work area, at dock level and ground level to prevent unauthorized use of the dock position while service work is being performed.

## Introduction

The following installation instructions are complete for all applications of the side frames that are normally available. Any application of the side frame that is outside of normal application guidelines, should be referred to Order Engineering for installation instructions. These instructions also assume that the installer is outside the building facing the loading dock position

## Illustrations

Illustrations for this document are contained on drawing #5656-0008

## Installation Standard

These instructions illustrate how to install a set of 6" side frames that are on a stand alone unit.

1. Before mounting side members, install the curtain top mounting brackets to side members at the top outside edge of the side members. Holes have been pre-drilled from the factory to locate the brackets. Install the two screws, making sure the brackets are on straight. (See Figure 1)

(Note: These brackets are not part of the over all unit width. Unit width when mounting side members should be measured from outside edge of side members. Brackets will add about 1/4" to over all foot print of unit and this allowance is taken into account on the header installations.)

(Note: For common member units, see that section first before proceeding. Variances in side frames mounting for common member units can cause installation problems. Take special care in installing common member side frames accurately. It is suggested to install common member side frame units first, then the standard units)

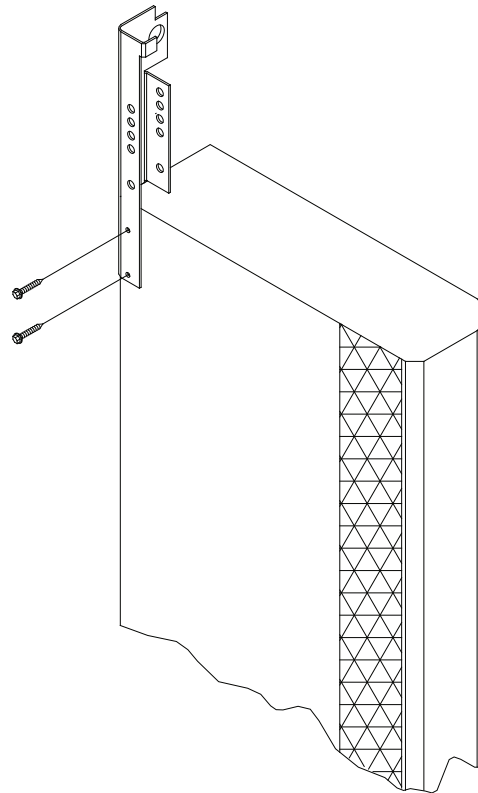

FIGURE 1

# 610 Series Side Frame Installation

2. Measure the dock door opening. Divide this measurement in half and mark the centerline of the opening at dock level. (See Figure 2)

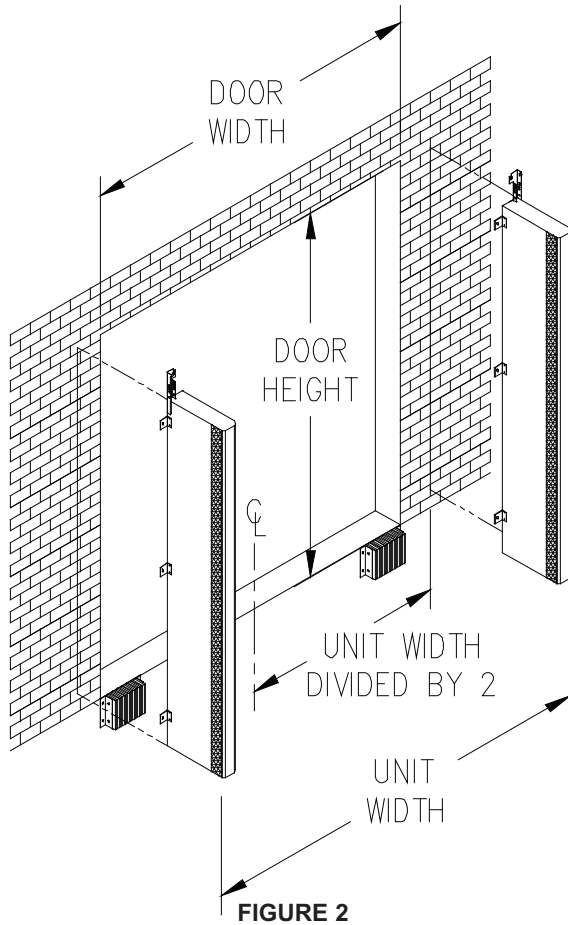

FIGURE 2

3. Measure the head member overall width and divide this measurement in half.
4. Measure from the door centerline half of the head member dimension and mark the outside wall at the bottom of the door opening or at dock level. This mark is for the outside edge of the side member. (See Figure 2)

**Note:** For units that are offset on the door opening, install side members with the proper Offset.

Reference the Product Application Form (PAF) or consult the sales representative for the appropriate mounting height. Typically, the bottom of the side pad/side frame is mounted at dock height, but some applications may require mounting them at a different location. (Example: When dock bumpers are mounted above dock height or above the pit floor on vertical leveler applications, it may be required to mount the bottom of the side pads/side frames at a height even with the top of the bumpers).

5. Measure from the mark for the outside edge of the side member across the door opening the full specified unit width (at dock level). Mark this measurement for the outside edge of the second side member. (See Figure 2). Using carpenter's level, plumb up the wall the height of the side member and mark the outside edge of the side member on the wall at top. Measure full width, etc. Using a plumb bob or carpenter's level make sure that the outside wall is plumb from the highest point on the side member location to dock level. Shim the side members as required.
6. See "Bracketing Details" section of these installation instructions for details on how to install the brackets that will be shipped with the side members.
7. Attach one side of the side members to the building wall first. Make sure this member is mounted correctly and plumb. Refer to "Fastening Methods" section of these instructions for the correct fastening method for the building style the side members are being installed on. Attach the second side member, using the first member and the marks on the wall as a reference. When finalizing the side members unit width, as noted in Step 1, make sure that the distance between the inside faces of the mounting brackets are least +1/8" wider than unit width but no more than 1/4" for ease of installation. Unit widths outside this range may be adjusted after by loosening side member clip brackets and header anchors. For best results, keep the unit width of the mounting brackets as close to above specifications. (See Figure 3)

(NOTE: If 4" side frame widths are being installed, go to section "4" Side Frame Width" for special instructions)

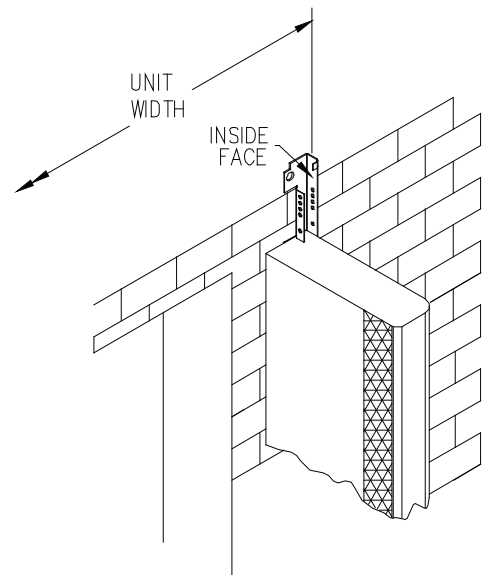

FIGURE 3

# 610 Series Side Frame Installation

## Instructions

### “Common Member”

This section of these installation instructions details how “common member” side frames are installed.

1. Follow steps 1 - 4 from the standard installation procedure for the side frame that are not common with another unit. (See Figure 5)
2. Follow step 1 from the standard installation procedure for the side frame that is common except install the common member header mounting bracket. (See Figure 4) Install screws on both sides of the frame.
3. Common member side frames will follow the same procedure as standard side frames, except that the side frame is centered on the unit width mark that was made on the wall. (See Figure 5)
4. See “Bracketing Details” section of these installation instructions for details on how to install the brackets that will be shipped with the side frames.
5. Attach the side frames to the building wall.

**Note: Take special care with common member side frames. Too much variances in mounting distances between header mounting brackets will cause installation problems with common member units. Read canopy style header installation instructions for common member units before proceeding.**

Refer to “Fastening Methods” section of these instructions for the correct fastening method for the building style the side frames are being installed on.

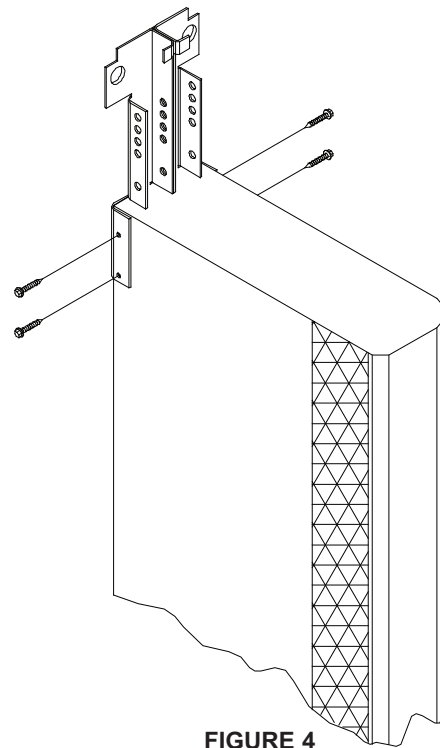

FIGURE 4

protection of the side member from being compressed completely to building wall.

**(Warning: Failure in not to install the bumpers and/or incorrectly installing of the bumpers could result in damage and/or failure of the unit. Always follow standard bumper fastening methods as described per each individual bumper models.)**

## 4" Side Frame Widths (40" or Less Projection)

These instructions list how to install a set of 4" side frames that are on a stand alone unit and < 40" in projection.

1. Reference the standard installation instructions 1531-0002 and 1321-0008 (blockout applications) along with these instructions before proceeding.
2. After Step 7 in 5656-0007 installation instructions, install the bumper provided as instructed in the bumper installation instructions 1531-0002. These bumpers must be installed.
3. Always install the side member in it's correction location and mount the bumper relative to the side member. Never install or adjust side member to bumper location. This bumper is required for the

## 4" Side Frame Widths (Greater than 40" Projection)

These instructions list how to install a set of 4" side frames that are on a stand alone unit and > 40" in projection.

1. Follow the standard installaion instructions for the 4" side frames.
2. Securely attach the side frame blockout at the further most point out from the building wall to either the bumpers, the building foundation, overhang, or any other appropriate rigid structure undersneath the side frames. This is required to stabilize the side frames while in use.

**(Warning: Failure to attach blockouts to the bumpers will result in damage and/or failure of the unit.)**

# 610 Series Side Frame Installation

---

## 4" Side Frame Widths

1. Reference the standard installation instructions 5656-0007 and 1531-0002 along with these instructions before proceeding.
2. All 4" side frame width blockout must use brackets to attach blockout to the building wall. This due to the lack of space between the boards in the construction of the blockouts.

**(Warning: Drilling out a space between the boards within the blockout, then thru bolting, is acceptable as long as the strength and integrity of the blockout is maintained.)**

## Fastening Methods

---

### Concrete Block or Brick Wall

1. Install fastener into mortar joint if possible. Use 3/8" x 4" lag screw with expansion shields, 3/8" x 4" one piece anchor with expansion collar, or equivalent fastener.
2. Through bolt fastening is required if the mortar joint will not support the members. Bore a hole through the building wall. Use a 3/8" dia. threaded rod with a washer, nut and jam nut on each end - it may be necessary to install a back-up plate - steel or wood - when the wall will not support the bolt.
3. Use a minimum of 6 brackets on each side member assembly.

### Concrete Tilt-Up Walls (Precast)

1. Use a 3/8" x 4" lag bolt with expansion shields, 3/8" x 4" one piece anchor bolts with expansion collar, or equivalent fastener. If building wall is too thin to effectively hold the lag bolt or anchor bolt, the through bolt method of attachment is required.

### Metal Side Building

1. Through bolt method of attachment is required for this building style. It will be necessary to install a back-up plate that is fastened directly to structural members when it is not possible to fasten directly to structural building members. Use a 3/8" diameter bolt with a washer and lock nut to fasten the unit to the structural members of the building or to the back-up plates. If necessary, use a 3/8" diameter

threaded rod with a washer and lock nut on each end.

### Bracketing Details

The side members are furnished with brackets to suit the application.

1. Position the side members on their marks.
2. Mark the side member for bracket installation. The brackets should be positioned 12" - 15" from the top and bottom, and also centered on the side member. (See Figure 6) For example, line up the mounting hole on the bracket with a mortar joint on the wall and attach the mounting bracket to the side member backer board.
3. Attach the brackets to the side member backer. Use the supplied 1/4" x 1 1/4" wood screws for wood backers, or #12 x 3/4" tek-screws for steel backers.

# 610 Series Side Frame Installation

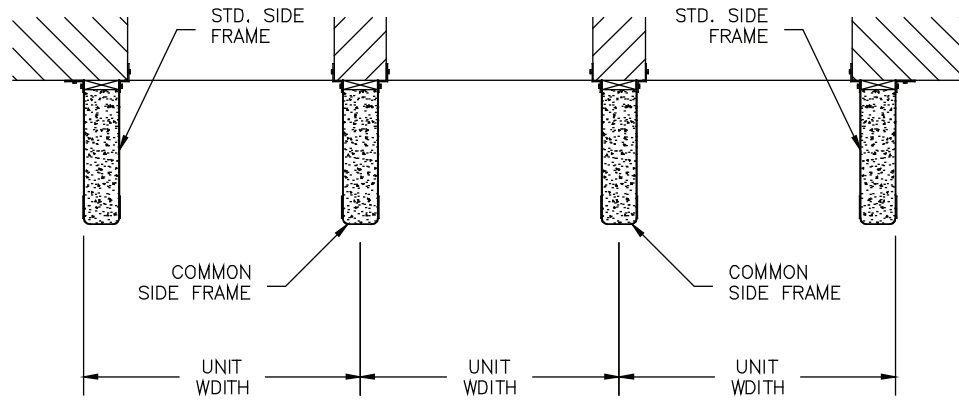

FIGURE 5

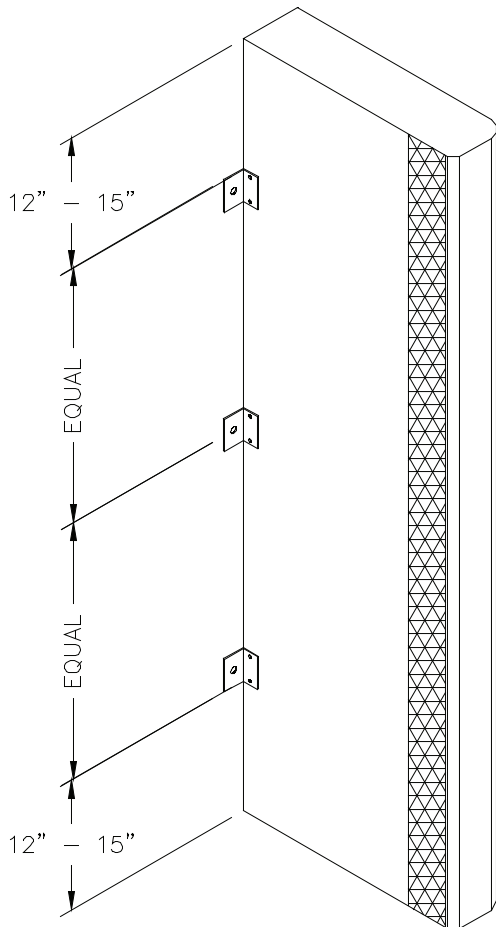
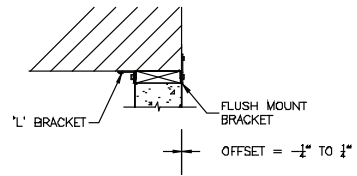
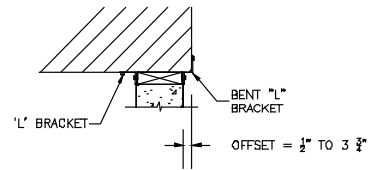

FIGURE 6

## FLUSH MOUNTING



## OFFSET MOUNTING



## OFFSET MOUNTING

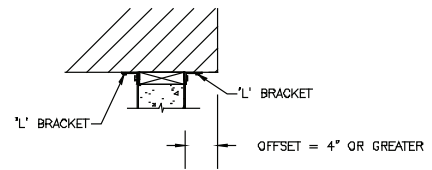

## "COMMON MEMBER MOUNTING

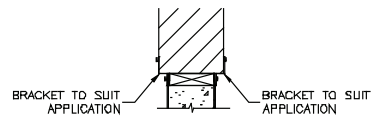

FIGURE 7

# 610 SERIES SIDE CURTAIN

## Table of Contents

File Information . . . . .	E1
General Precautions . . . . .	E1
Introduction . . . . .	E1
Illustrations . . . . .	E1
Installation Instructions . . . . .	E1
Standard Eliminator™ II . . . . .	E1
Common Member Eliminator™ II . . . . .	E2
Standard Eliminator™ -Gapmaster™II . . . . .	E2

## File Information

Document Name: 2860-0003  
Date Last Revised: 08/19/04  
Revision Letter: None

## General Precautions

**! WARNING!!!**

Post safety warning and barricade work area, at dock level and ground level to prevent unauthorized use of the dock position while service work is being performed.

## Introduction

The following installation instructions are complete for all applications of the side frames that are normally available. Any application of the side frame that is outside of normal application guidelines, should be referred to Order Engineering for installation instructions. These instructions also assume that the installer is outside the building facing the loading dock position

## Illustrations

Illustrations for this document are contained on drawing #2860-0004

## Installation

### Standard Eliminator™ II

These instructions illustrate how to install a pair of Eliminator™ II Side Curtains that are on a stand alone Unit.

1. Align top edge of side curtain to top edge of side frame at the same time aligning the velcro flap on the outside of the side curtain to the velcro on the outside of the side frame. (See Figure 1)
2. Make sure that the velcro flap on the outside of the side curtain completely covers the velcro on the side frame. (See Figure 2)
3. Continue to align the velcro flap to the outside of the side frame velcro at the top, and continue working downward to the bottom of the side frame. Keep continuous downward pressure on side curtain to avoid wrinkles in fabric.
4. Starting at the top, repeat Steps 1 & 2, to the inside velcro flap on the side curtain. However, due to variations, the velcro flap on the side curtain may not always cover the velcro on the inside face of the side perfectly. It is important to make sure the side curtain is perpendicular to the side frame when finished. (**Note: Always align outside velcro flap first.**)

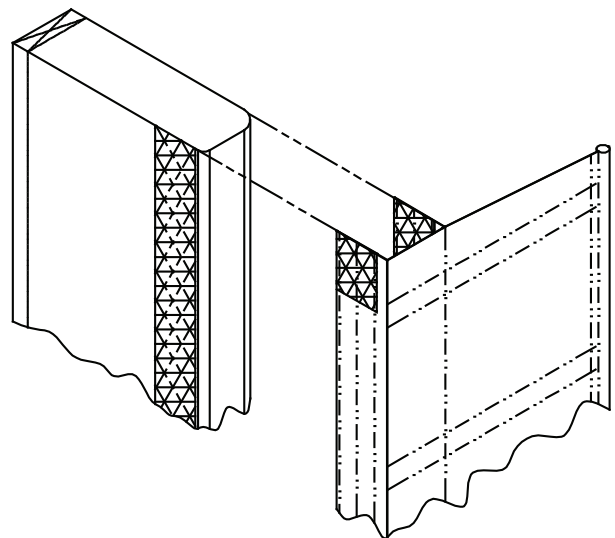

FIGURE 1

# 610 Series Side Curtain Installation

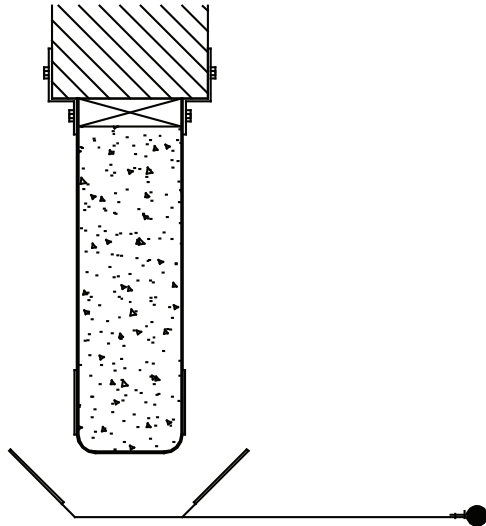

FIGURE 2

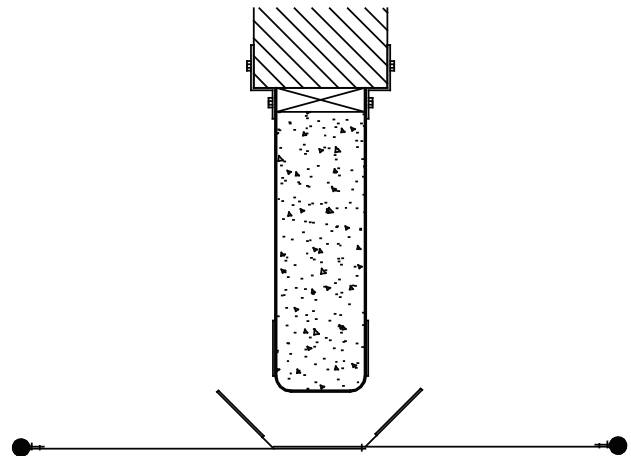

FIGURE 3

## Common

### Member Eliminator™ II

These instructions illustrate how to install a pair of Eliminator™ II Side Curtains on a common member side frame.

1. Align top edge of side curtain to top edge of side frame at the same time aligning one of the velcro flaps on the inside of the side curtain to the velcro on the inside of the side frame on the same side. (See Figure 3)
2. Make sure that the velcro flap completely covers the velcro on the side frame.
3. Continue to align the velcro flap to the side frame velcro at the top, and continue working downward to the bottom of the side frame. Keep continuous downward pressure on side curtain to avoid wrinkles in fabric.
4. Starting at the top, repeat Steps 1 & 2, to the other inside velcro flap on the side curtain assembly. However, after the velcro is attached, an adjustment may be needed to align the curtains properly. It is important to make sure that the side curtains are perpendicular to the side frame when finished.

## Standard

### Eliminator™ -GapMaster™ II

These instructions illustrate how to install a pair of Eliminator™-GapMaster™ II Side Curtains that are on a stand alone unit.

1. Align top edge of side curtain to top edge of side frame at the same time aligning the velcro flap on the outside of the side curtain to the velcro on the outside of the side frame. (See Figure 4)

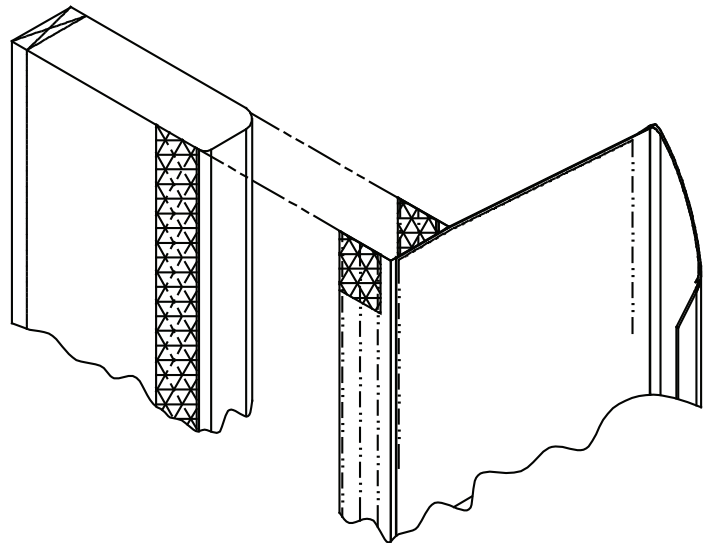

FIGURE 4

# 610 Series Side Curtain Installation

---

2. Make sure that the velcro flap on the outside of the side curtain completely covers the velcro on the side frame. (See Figure 5)
3. Continue to align the velcro flap to the outside of the side frame velcro at the top, and continue working downward to the bottom of the side frame. Keep continuous downward pressure on side curtain to avoid wrinkles in fabric.
4. Starting at the top, repeat Steps 1 & 2, to the inside velcro flap on the side curtain. However, the Eliminator™-GapMaster™ II side curtains are intentionally made to “toe” or angle inward toward the door opening or building wall. (See Figure 5) The outside velcro flap on side curtain is made longer than the inside velcro flap. This is done to reduce the effects of the hook pushing the curtain face out on the header assembly. It is important to make sure the side curtains are installed in this fashion. The inside velcro flap on the side curtain will overlap and go past the velcro on the inside of the side frame. This is normal.

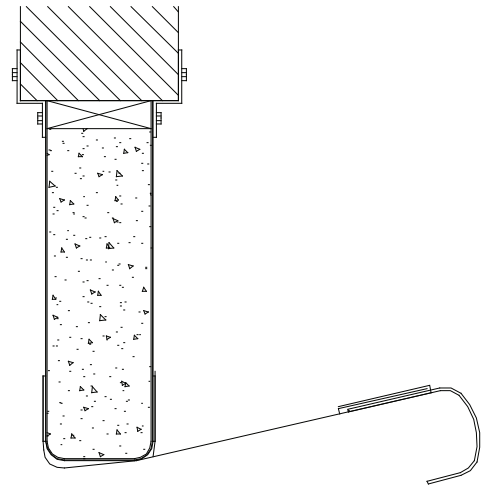

FIGURE 5

# 610 SERIES CANOPY STYLE HEADER

## Table of Contents

File Information	F1
General Precautions	F1
Introduction	F1
Illustrations	F1
Installation Instructions	F1
Standard Canopy Style Header	F1
Flat Pitch "Over the Sides"	F4
Integral Hood	F4
Common Member	F5
"Drive Thru" Face Curtain Brackets	F7
Fastening Methods	F7

## File Information

Document Name:	1610-0003
Date Last Revised:	06/22/11
Revision Letter:	D

## General Precautions



**WARNING!!!**

Post safety warning and barricade work area, at dock level and ground level to prevent unauthorized use of the dock position while service work is being performed.

## Introduction

The following installation instructions are complete for all applications of the canopy style header that are normally available. Any application of the canopy style header that is outside of normal application guidelines, should be referred to Order Engineering for installation instructions. These instructions also assume that the installer is outside the building facing the loading dock position.

## Illustrations

Illustrations for this document are contained on drawing #1610-0004

## Installation

### Standard Canopy Style Header

These instructions illustrate how to install a standard pitch canopy style header on a stand alone unit and assume that the header mounting brackets are installed on side frames.

1. Lift the top curtain/bar assembly while still packaged together and locate across the already installed side frames. Position it on top so as the side arms on the top frame are facing the wall and land between the mounting brackets on side frames. (See Figure 1)

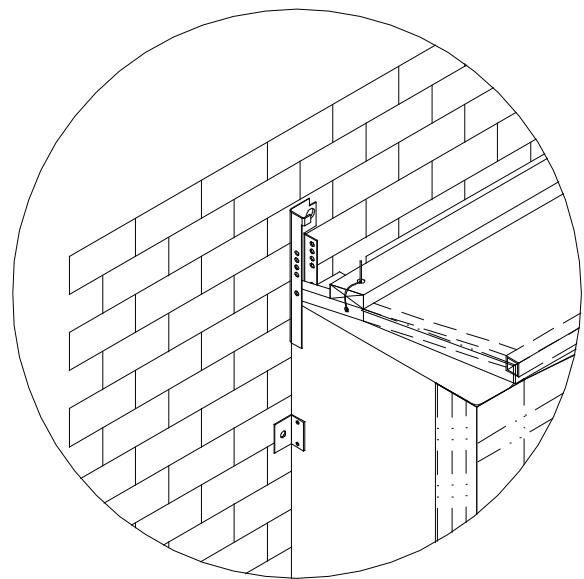

FIGURE 1

2. Starting from the either side, cut the tie to release the backer board free of the packaged assembly. Once free, slide the backer board towards the middle of side frame.
3. Insert the clevis pin in from outside until it comes through the inside of the bracket. Install the supplied bridge pin so it cannot slide back out. Do this for both sides. (See Figure 2)

# 610 Series Canopy Style Header Installation

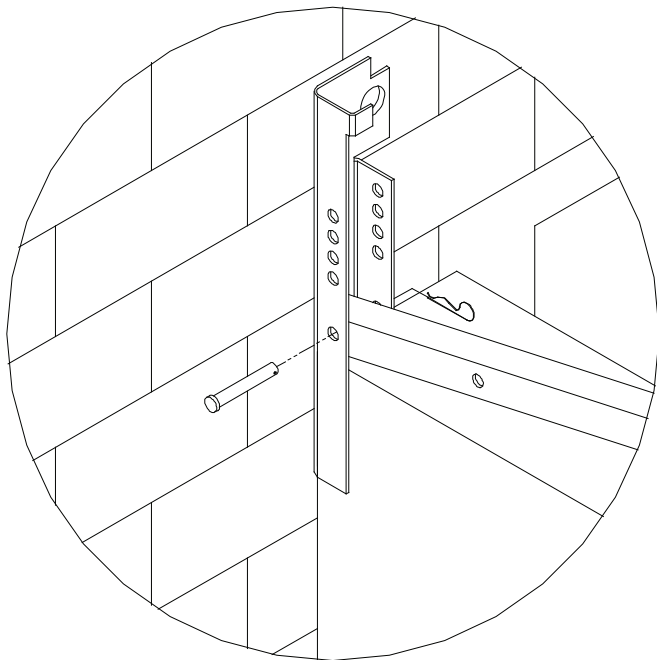

FIGURE 2

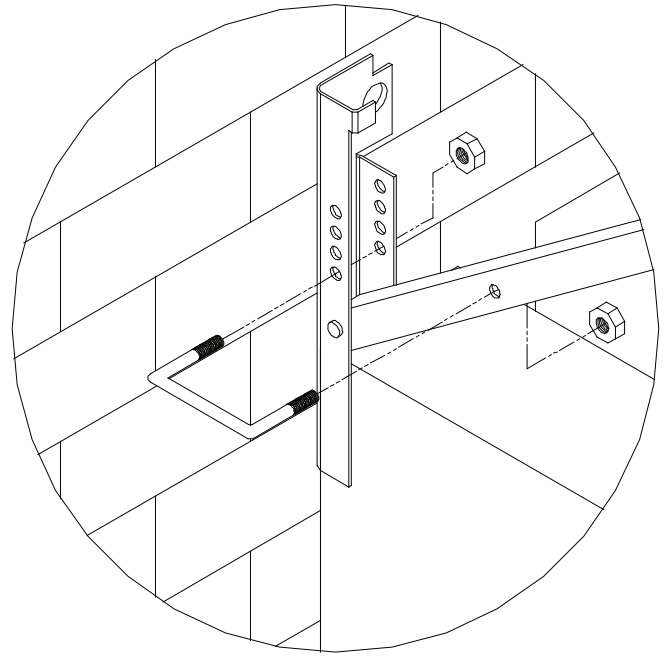

FIGURE 3

4. Push the backer board back towards the mounting bracket.
5. At this point, the header mounting brackets can be drilled or you can wait until after Step 7. To do it now, make sure the distance between mounting brackets is correct for the unit to be installed. (Reference 5656-0007, Figure 3) Drill appropriate hole for the style of anchor to be used, into the center of the 1" diameter hole on the header mounting bracket.
6. Repeat this procedure for the other side.
7. While still on the side you just finished, slide one end of the installation safety "U" bolt 1/3 the way into the hole located on the side arm of the top frame assembly. Lift the front bar assembly until the "U" bolt aligns with the desired hole on the header mounting bracket. (See Figure 3) (Note: The correct hole is when the "U" bolt can be installed and leave an ample amount of slack in the cover in order to get backer board into the header mounting bracket.) Install the "U" bolt all the way through the holes. Attach the supplied nuts to the "U" bolt threads. For normal installations, the nuts just can be hand tightened
8. Slowly lower the front bar down allowing the "U" to take up the load.
9. Position yourself under the middle of the header assembly. Slowly pick up the backer board and position it behind the tabs on the header mounting brackets. Insert one side first, then the other. Make sure nailed end of backer board faces downward and goes into bracket first. Then seat both completely. Do not push too hard, mounting bracket is not mounted to wall yet. The backer bar should rest on flange part on the mounting bracket. (See Figure 4)
10. Install a minimum of (5) anchors into the wall that the header is to be mounted to. (Refer to "Fastening Methods" section for correct anchors and attachment methods for the building style the curtain is being installed on.) If not done already, two of the (5) anchors need to be mounted on the ends of the backer board. (See Figure 5) These holes are pre drilled at the factory for correct location. These anchors provide load bearing for the backer board and they also anchor the mounting brackets to wall.

## **! WARNING!!!**

**Do this slow, because the mounting brackets are not anchored. Dropping the front bar could cause damage to unit**

## **! WARNING!!!**

**These two anchors must be installed through the bracket. Failing to do so, could cause injury and failure of the unit to function properly.**

# 610 Series Canopy Style Header Installation

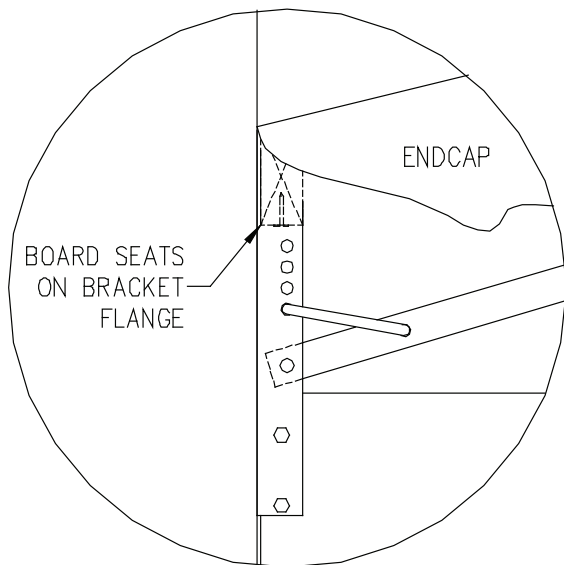
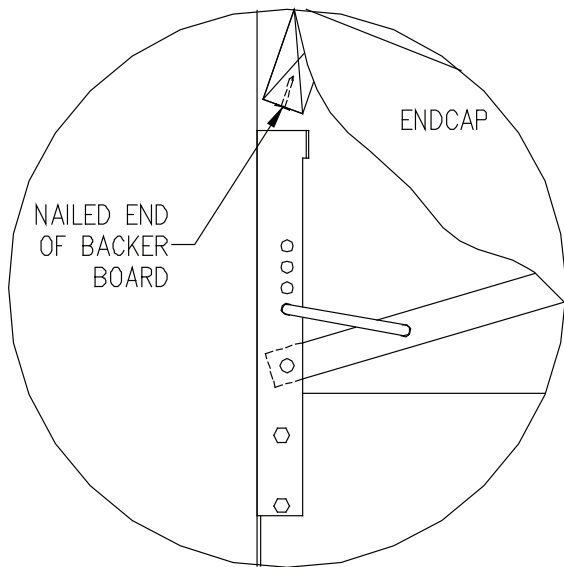

**FIGURE 4**

Install three more anchors into the backer board in the middle area of the unit. Install (1) centered into the backer board based on the unit width, the other two can be centered in the spaces left between each end anchor and the center anchor. The three anchor locations between the mounting brackets can vary in location by +/-2" max.

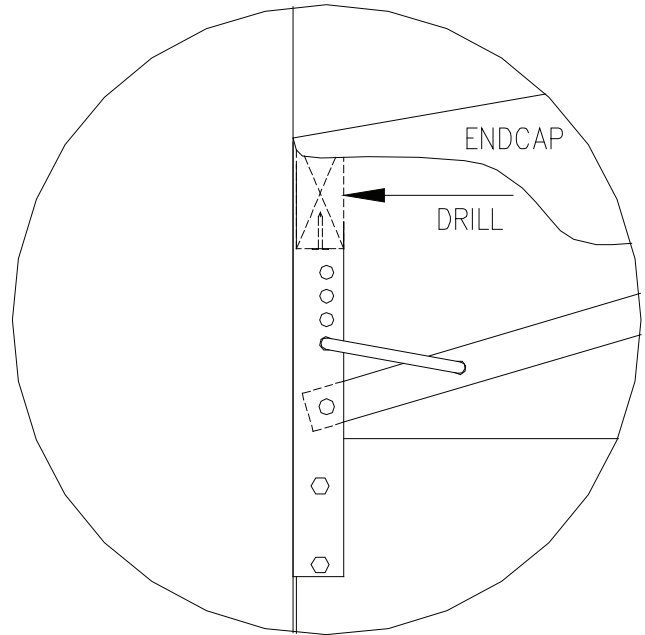

**FIGURE 5**

## **! WARNING!!!**

The header unit is a self supporting unit and requires proper installation because of the load imposed on the frame. Installing less than the recommended amount of (5) anchors, changing anchoring locations and/or insufficient anchors installation methods will be dangerous, and have possible unit failure. Note: Metal sided buildings are required to have backup plates installed and/or be installed into suitable existing building girt or purlins to sufficiently support the header assembly for heavy loads situations.

11. Once all the anchors are installed. Go back to right side of the header assembly and release the safety "U" bolt. Again, release the load of the front bar to mounting bracket slowly.
12. Once the front bar is self supporting, check the locations of the curtain corners. Make sure there are no hang ups of fabric. The header is self supporting and heavy loads can be seen, it is important that the corners fit properly. Once, the corners are correct, bounce the header up and down slightly. Do this by pushing up the fabric in the middle of the header from underneath the inside of the top. This helps pull the fabric around front bar before curtain face is installed. Do this lightly, push up front bar maximum of about 1/2".

# 610 Series Canopy Style Header Installation

13. Caulk along the entire edge of the canopy top at the building wall, making sure the ends are covered. Use a good grade of flexible caulk.
14. Pull the end caps, located at each end, down to cover the side frame. Attach the end cap to the side frame backer using one of screws holding on the mounting bracket. Attach the velcro on the inside of the endcap to the velcro on the top flap of side member.
15. Finally, wrap the end caps front flaps onto the front bar velcro. (See Figure 6) Align edge on end cap to top edge of the front bar itself. Do not align to velcro. Also, do not pull end cap tightly around corner. Allow the end cap to wrap corner loosely. This allows the header to flex and proper movement of side members relative to header during normal operation. (See Figure 6)

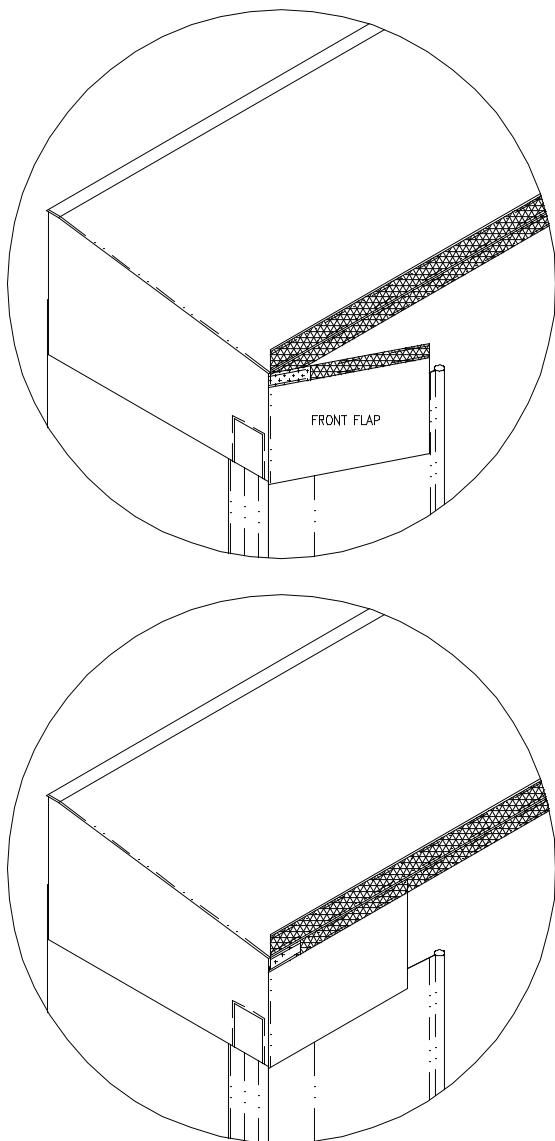

FIGURE 6

## Instructions

### Flat Pitch - Over the Sides

The instructions for a flat pitch are the same as for a standard pitch. The only differences is the header mounting bracket which is made shorter to achieve the flat top (Standard flat pitch comes without a gutter)

## Instructions

### Integral Hood

The instructions for a integral hood are the same as for a standard pitch, except as noted below. The major difference is the header mounting bracket which is made longer to achieve the greater pitch.

1. Before starting Step 5 of the standard canopy style header installation procedure, install an extra anchor/fastener through the brackets at the top of mounting bracket just below the area used for the backer board. (See Figure 7) With the increased height of the mounting bracket, extra support is needed to hold bracket to wall before attaching the front bar assembly. The front bar assembly imposes a load on the bracket and with the increased height, the load is increased. Make sure bracket is in the

## **! WARNING!!!**

**This anchor/fastener is required for installation. Failing to do so, could cause injury.**

correct location before attaching. Verifying bracket spacing at this time is suggested.

2. Return to Step 5 of standard pitch canopy style header installation procedure.

# 610 Series Canopy Style Header Installation

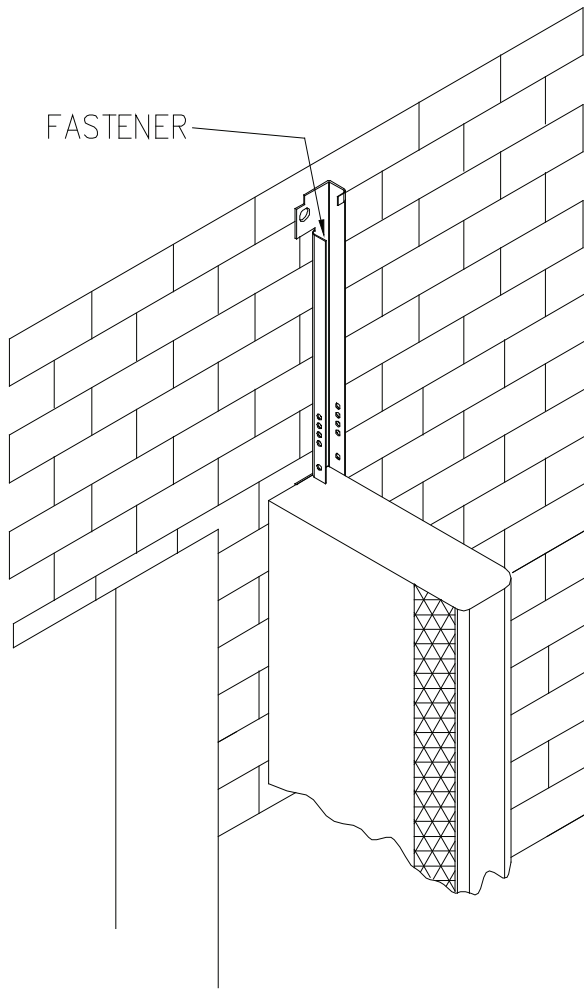

FIGURE 7

Always verify mounting distances between header mounting brackets. Too much variances in mounting distances can cause installation problems with common member units.)

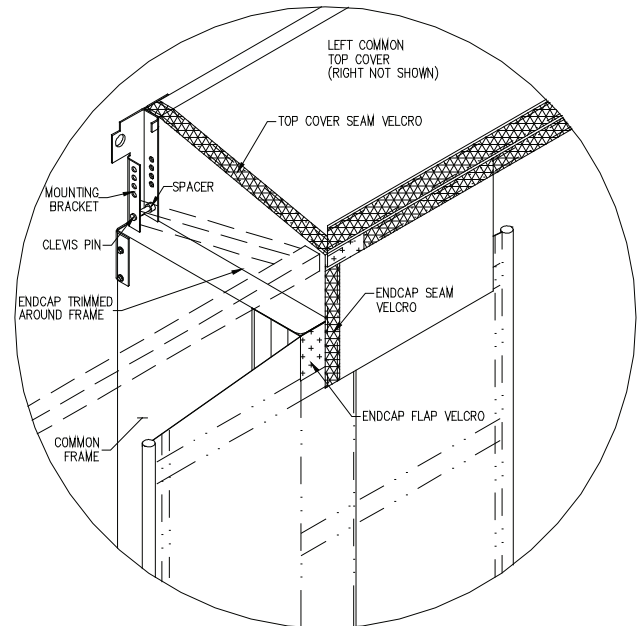

FIGURE 8

## Instructions Common Member

These instructions illustrate how to install a standard canopy style header, a flat pitch or an integral hood with a common member side frame and assumes that the header brackets are installed on side frames.

1. Starting from either side of the common member side frame, lift the top curtain/bar assembly while still packaged together and locate across the already installed side frames. Position it on top so as the side arms on the top frame are facing the wall and land between the mounting brackets on side frames, particularly on side of the common member. (See Figure 8)

**(Note: When installing common member canopy style headers, it is easier to start from the common member units and working your way to the standard units. Start from the center units (if applicable) and work your way out.**

2. Next, lift the top curtain/bar assembly that correspond to the other side of the common member unit. Follow the same procedure as the first for locating this assembly.
3. Cut the ties to release the backer board free of the packaged assembly. Once free, slide the backer board towards the middle of side frame.
4. Starting at the common member side frame, insert the clevis pin in from one side of the common mounting bracket through both individual header side arms and out the other side the bracket. (See Figure 9) While inserting the pin, install the nylon spacers between the side arm (not shown) and middle section of the bracket. One spacer goes on each side of the middle section. The spacers are used only on the common member mounting brackets and are there to keep each header assembly on the common member side frame spaced apart from each other. Install the supplied bridge pin so it cannot slide back out. Do this for each common member and then for the standard side frames.
5. Push the backer boards back towards the mounting bracket.

# 610 Series Canopy Style Header Installation

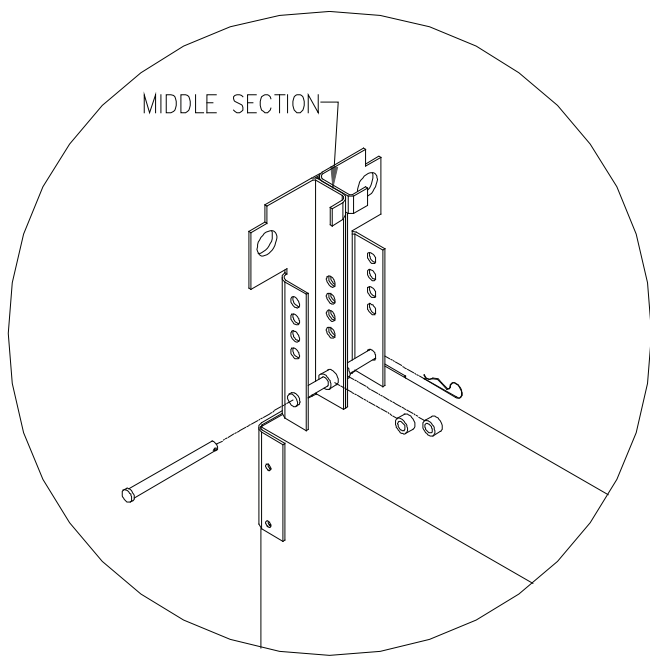

**FIGURE 9**

6. For one side of the common member unit only, continue with Steps 5-12 of the standard canopy style header installation procedure. Then return to step 7 of these instructions.
7. Pull the end cap located on the common member side frame end, down into position. (See Figure 8) The endcap is designed to fit around the mounting bracket and top of side frame. There should be approximately 1" of material left over. This material can be used to trim to fit or left loose.
8. Finally, wrap the end cap front flap onto the front bar of header assembly at the same time attaching it to the endcap flap velcro located at the top, front face of the side curtain. (See Figure 6 & 8) Align edge on end cap to top edge of the front bar itself. Do not align to velcro. Also, do not pull end cap tightly around corner. Allow the end cap to wrap corner loosely. This allows the header to flex and proper movement of side members relative to header during normal operation. For common member units, the endcap front face attaches to side frame via the velcro on the top, front face of the side curtain while on standard units it is attached to velcro on the side.
9. Repeat this procedure for the other corresponding header assembly used on the common member side frame. (Note: The canopy covers of the common member unit may need to be adjusted for the two tops to fit properly. Adjust by repositioning polystrip loop in front bar frame assembly. Canopy cover ends should just touch or have a small space between them)

10. Attach the endcap seam flap. (See Figure 10) Do

this by centering it between the two vertical velcro strips sewn on the endcaps front face. Starting at the bottom, align the seam flap to the bottom of the endcap and go up. Do not lay seam flap completely flat, but allow some slack between the velcro seams for header movement. The seam flap should tuck under the front bar flaps on canopy covers. The face curtains will mount under the front bar flaps, but over top of the endcaps and the seam.

11. The curtain face can either be installed now or after the last steps in these instructions.
12. Attach the top cover seam flap. (See Figure 10) This seam flap needs to go from the canopy back edge at wall, and follow the velcro on the top cover down and over front bar flap. Do not lay seam flap completely flat, but allow some slack between the velcro seams for header up and down movement. The end of the seam flap should end up even with the edge of the front bar flap. Adjust and trim at building wall if necessary.
13. Nail the back of the top cover seam flap at the building wall. Put (1) nail on each side into the header backer boards of each canopy. (See Figure 10)
14. Caulk along the entire edge of the canopy top at the building wall, making sure the ends are covered. Use a good grade of flexible caulk.

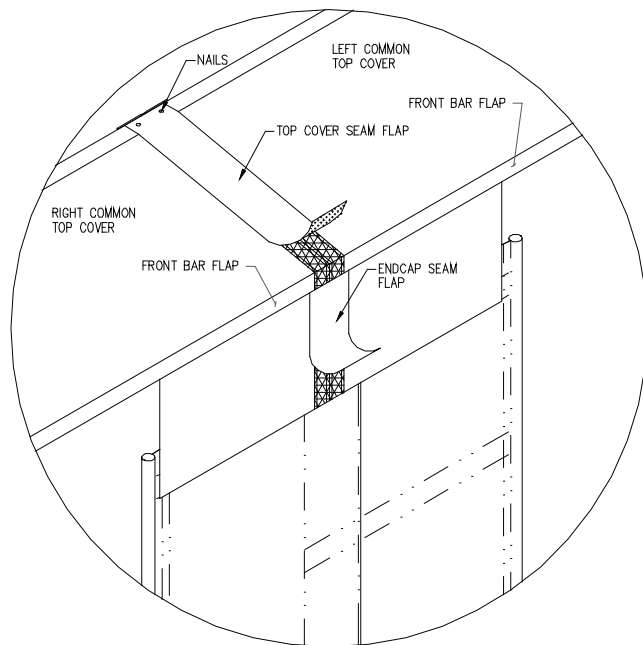

**FIGURE 10**

# 610 Series Canopy Style Header Installation

---

## Instructions

### "Drive Thru" Face Curtain Brackets

These instructions illustrate how to install face curtain brackets that are required for the proper function of the C4 Style Face Curtain when applied in the "Drive Thru" application. **Failure to install these brackets could result in face curtain damage during operation.**

There are two methods of attaching brackets to canopy frame, either before face curtain installation or after. These instructions are applicable for either way, but are written specifically for installation of the brackets before the face curtain installation. Make appropriate changes if attaching after face curtain installation.

1. Before attaching face curtain to canopy header, attach the (3) face curtain brackets to canopy front bar.
2. First, find the center of the canopy front bar where face curtain is to be attached and mark the location on the backside of the front bar, underneath the canopy. This marks the location of the first and center bracket. (See Figure 11) (Note: this can be done on the ground for ease of installation)
3. From the center location, make (2) more marks, 34" away in each direction. These mark the outside bracket locations. (See Figure 11)
4. Using the provided self drilling/tapping screws, attach each bracket the backside of the front bar. The brackets go thru the canopy cover mounting flap and thru the angle welded on the front bar. (See Figures 11, 12 & 13)
5. The brackets need to be relatively centered on the stays on the face curtain. They will be mounted slightly forward and should contact the face curtain when the face curtain gets attached. (See Figure 13) Make sure the brackets are securely attached to front bar and screws are seated all the way in. **DO NOT OVER TIGHTEN AND STRIP SCREWS!**
6. Attach the face curtain per the standard instructions.  
(Note: The brackets can be attached after the face curtain, except it is a little more difficult.)

## Fastening Methods

---

### **Concrete Block or Brick Wall**

Through bolt fastening is required. Bore a hole through the building wall. Use a 3/8" diameter threaded rod with a washer, nut and jam nut on each end - it may be necessary to install a back-up plate inside the building wall when the wall will not support the bolt.

### **Concrete Tilt-Up Walls (Precast)**

Use a 3/8" lag bolt with expansion shields, 3/8" one piece anchor bolts with expansion collar, or equivalent fastener. If building wall is too thin to effectively hold the lag bolt or anchor bolt, the through bolt method of attachment is required.

\* See anchor manufacturer's recommendation for minimum anchor embedment to determine appropriate anchor length.

### **Metal Side Building**

Through bolt method of attachment is required for this building style. It will be necessary to install a back-up plate that is fastened directly to structural members when it is not possible to fasten directly to structural building members. Use a 3/8" diameter bolt with a washer and lock nut to fasten the unit to the structural members of the building or to the back-up plates. If necessary, use a 3/8" diameter threaded rod with a washer and lock nut on each end.

# 610 Series Canopy Style Header Installation

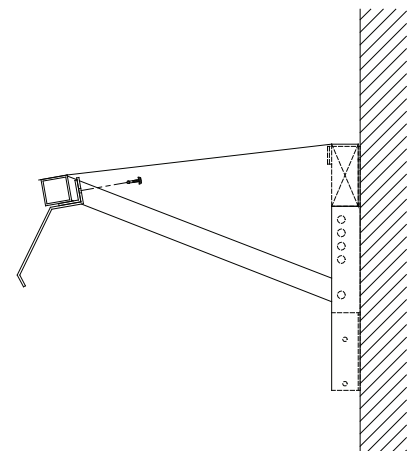
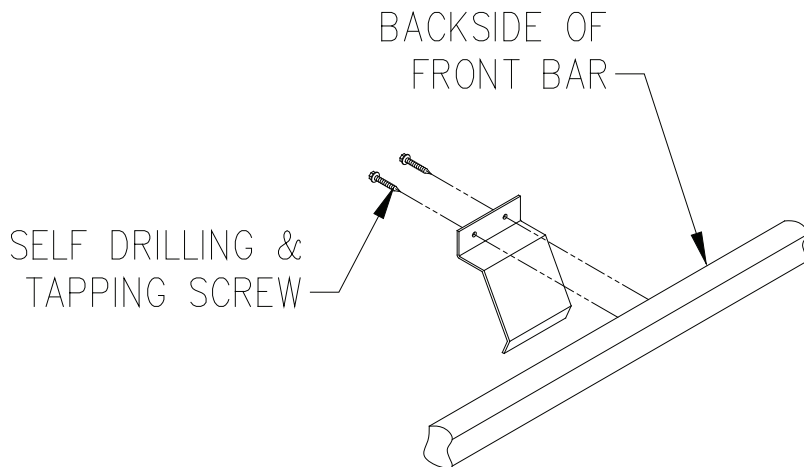
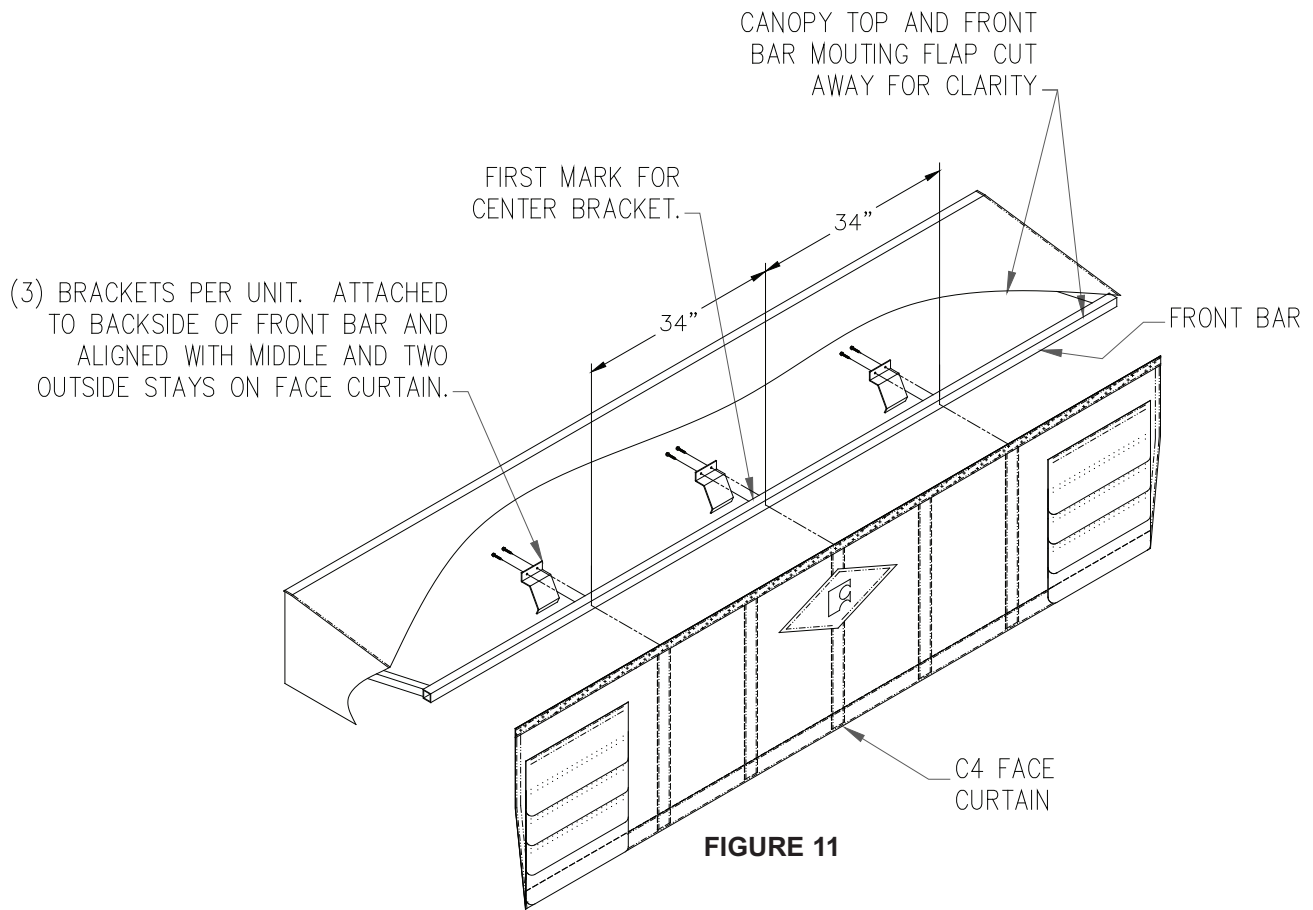

# 610 SERIES C-STYLE CURTAIN

## Table of Contents

File Information . . . . .	G1
General Precautions . . . . .	G1
Introduction . . . . .	G1
Illustrations . . . . .	G1
Installation Instructions . . . . .	G1
C Style Curtain . . . . .	G1
Windstraps, standard . . . . .	G2
Windstraps, Common Member . . . . .	G2
Pull Rope Cleat . . . . .	G2
Operation of Pull Rope . . . . .	G3

## File Information

Document Name:	2861-0002
Date Last Revised:	03/01/05
Revision Letter:	A

## General Precautions



**WARNING!!!**

**Post safety warning and barricade work area, at dock level and ground level to prevent unauthorized use of the dock position while service work is being performed.**

## Introduction

The following installation instructions are complete for all applications of the C-style curtain that are normally available. Any application of the C-style curtain that is outside of normal application guidelines, should be referred to Order Engineering for installation instructions. These instructions also assume that the installer is outside the building facing the loading dock position.

## Illustrations

Illustrations for this document are contained on drawing #2861-0003

## Installation

### C-Style Curtain

These instructions illustrate how to install a standard C-style curtain face on a stand alone unit and assumes that the header brackets are installed on side members.

1. Located on the canopy top cover front flap is a small tab that locates the center of the unit. Marking this location makes it easier to install curtain face. (Note: Verification of this location can be done by measuring across the top of the front of the unit and dividing this measurement by 2.)
2. Locate center of c-style curtain face by locating a small tab at center. Marking this location makes it easier to install curtain face. Also, there are tabs that locate other attachment points on curtain face. Marking these locations will make it easier to install curtain face.
3. Using the velcro on the curtain face and velcro on the front bar, temporarily hang the curtain face from the canopy top cover. Make sure curtain face top edge is aligned with the front bar. There will be slight variations in the velcro location on the front bar, so make sure you align the two edges and not the velcro(s). Also, make sure that the curtain face is underneath the canopy top cover front flap and that it is centered on the mark made in the previous step. (See Figure 1) (Go to 5162-0004 for gutter installation instructions)
4. **Attach the curtain face to the front bar using the supplied tek-screws and washers.** Fasteners should align with tabs marked at specified locations on curtain face and also half way down the front bar. The screws are intended to drill through the Velcro, the stay and the front bar at the same time. There are no pre drilled holes, so take care in centering the fasteners correctly. Make sure that the large thin washer is between the front curtain and the tek-screw head. Install screws in every stay location, and three to four screws on each end, past the last stay on each side. The last screw on the outside is always located 1" off the curtain face outside edge. (Note: do not get last screw too close to outside. Leave 1" of curtain remaining.) Install the rest of the screws evenly in space provided. Make sure at least three screws are installed through the end cap front flap and of those three screws, at least one catches the last inch of the end cap towards the middle. In some situations, all of these screws will land in end cap front flap.

# 610 Series C-Style Curtain

5. Lay the canopy top cover front flap with velcro over the newly installed curtain face and screws. Take care in positioning the flap so it is even along the front of the unit. This flap keeps the water from entering behind the front curtain.
6. Locate pull ropes previously installed at factory. Attach each pull rope to corresponding loop on curtain face backside. Make sure knot is secure.

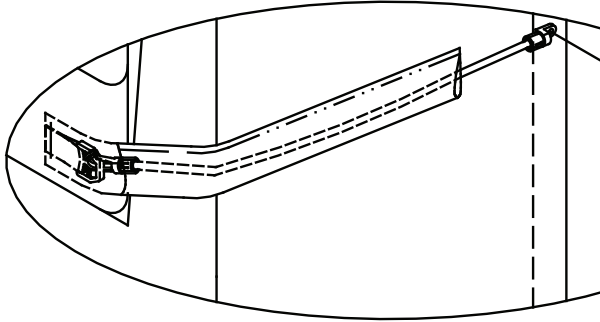

FIGURE 1

## Instructions

### Windstraps, "Standard"

These instructions illustrate how to install windstraps on a standard unit. This does not apply to "Common Member" installations.

1. Locate the windstrap attachment rings on each front end edge of the head curtain. (See Figure 2)
2. Feed the hook end of the windstrap through the fabric pocket on the vertical edge of the curtain, and attach the hook end of the windstrap to the attachment rings.
3. Pull the windstrap toward the side member backer board. **Make sure that the windstrap is horizontal, not angled up or down.**
4. Using the supplied screws attach the eyelet end of the windstrap to the backer board of the side member. There should be some slack in the windstrap after installation. (See Figure 2)

**NOTE: - DO NOT ATTACH USING HAMMER & NAILS. - DO NOT OVER TIGHTEN SCREWS. EYELET SHOULD SWIVEL FREELY AFTER INSTALLATION.**

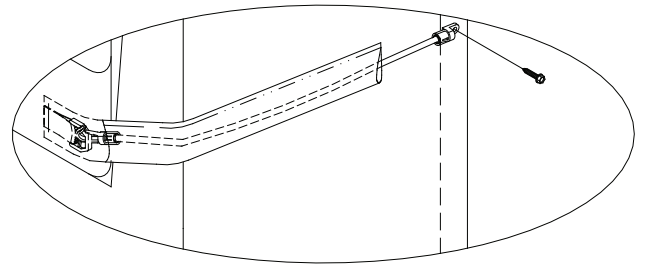

FIGURE 2

## Instructions

### Windstraps, "Common Member"

These instructions illustrate how to install windstraps on a "Common Member" c style curtain.

1. Locate the windstrap attachment rings on each front edge of the head curtain. (See Figure 3)
2. Attach the hook end of the windstrap to the attachment rings. (See Figure 3)

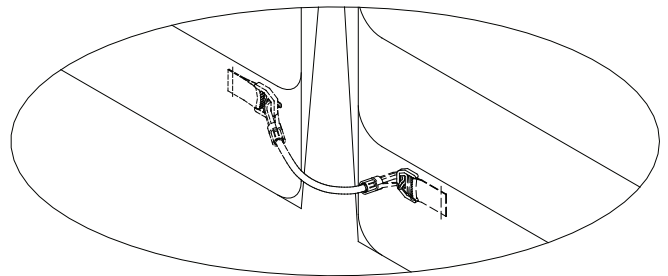

FIGURE 3

## Instructions

### Pull Rope Cleat

1. Position pull rope cleat at a comfortable height on the left side member backer board.
2. Secure cleat into position using the supplied screws. (See Figure 4)
3. Anchor pull ropes to the cleat.  
**Note: Certain applications may make it necessary to locate the pull rope cleat elsewhere for accessibility.**

# 610 Series C-Style Curtain

---

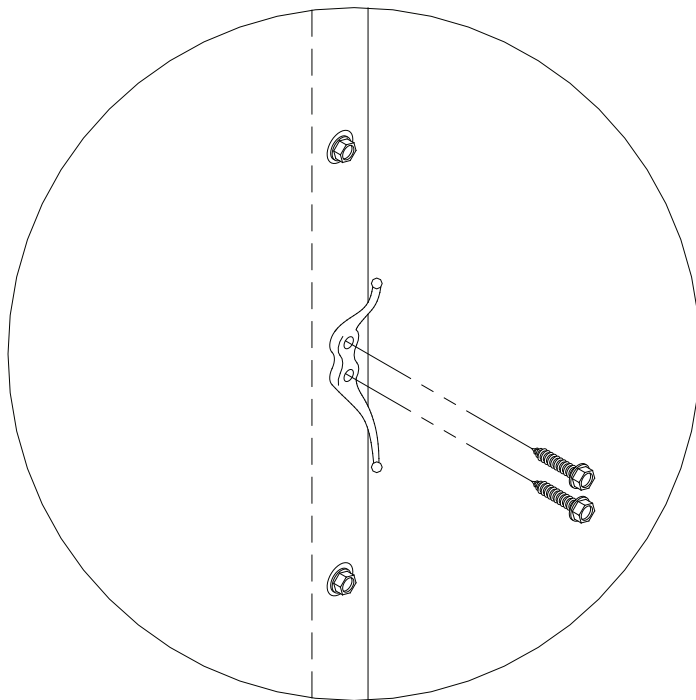

FIGURE 4

## Instructions

### Operation of Pull Ropes

Most C style curtains are factory equipped with pull ropes. This allows the curtains to be adjusted in the field to allow a wide variety of trucks heights to be serviced and sealed by the same dock and dock seal or shelter.

These pull ropes should be operated according to the following diagram in order to raise the center section of the curtain out of the door opening of the trailer. After the truck leaves the dock, the pull ropes should be lowered in preparation for the next truck.

Secondary pull ropes (Optional) should be operated in the same manner to further raise the curtain out of the door opening of the trailer. (See Figure 5)

# 610 Series C-Style Curtain

---

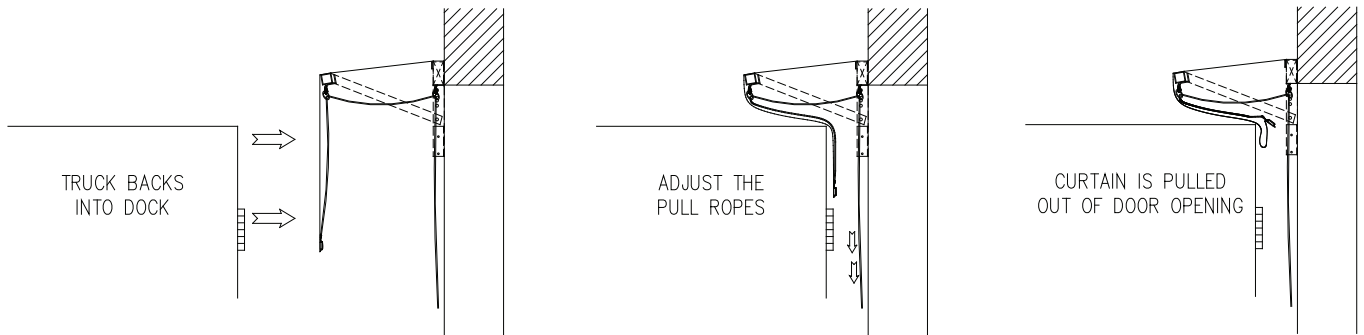

**FIGURE 5**

---

---

# 610 SERIES C4-STYLE CURTAIN

---

---

## Table of Contents

---

File Information . . . . .	H1
General Precautions . . . . .	H1
Introduction . . . . .	H1
Illustrations . . . . .	H1
Installation Instructions . . . . .	H1
C4 Style Curtain (Up to 15'3" Off Grade) . . . . .	H1
C4 Style Curtain (15'4" Off Grade and Over) . . . . .	H2
C4 Style Curtain (15'4" Off Grade and Over Common Member) . . . . .	H2

## File Information

---

Document Name:	2862-0002
Date Last Revised:	04/13/07
Revision Letter:	C

## General Precautions

---



**Post safety warning and barricade work area, at dock level and ground level to prevent unauthorized use of the dock position while service work is being performed.**

## Introduction

---

The following installation instructions are complete for all applications of the C4-Style Curtain that are normally available. Any application of the C4-Style curtain that is outside of normal application guidelines, should be referred to Order Engineering for installation instructions. These instructions also assume that the installer is outside the building facing the loading dock position.

## Illustrations

---

Illustrations for this document are contained on drawing #2862-0003

## Installation

### C4-Style Curtain (Up to 15'3" Off-Grade)

---

These instructions illustrate how to install a standard C4-Style curtain face mounted up to and including 15'-3" off grade on a stand alone unit and assumes that the header brackets are installed on side members.

1. Located on the canopy top cover front flap is a small tab that locates the center of the unit. Marking this location makes it easier to install curtain face. (Note: Verification of this location can be done by measuring across the top of the front of the unit and dividing this measurement by 2.)
2. Using the velcro on the curtain face and velcro on the front bar, temporarily hang the curtain face from the canopy top cover. Make sure curtain face top edge is aligned with the front bar. There will be slight variations in the velcro location on the front bar, so make sure you align the two edges and not the velcro(s). Also, make sure that the curtain face is underneath the canopy top cover front flap and that it is centered on the mark made in the previous step. The middle stay on the C4 Style curtain face should align with the mark made in step 1. See Figure 1) (Go to 5162-0004 for gutter installation instructions)
3. **Attach the curtain face to the front bar using the supplied tek-screws and washers.** Fasteners should align with center of stays and be located half way down the front bar. The screws are intended to drill through the Velcro, the stay and the front bar at the same time. There are no pre drilled holes, so take care in centering the fasteners correctly. Make sure that the large thin washer is between the front curtain and the tek-screw head. Install screws in every stay location, and three to four screws on each end, past the last stay on each side. The last screw on the outside is always located 1" off the curtain face outside edge. (Note: Do not get last screw to close to outside. Leave 1" of curtain remaining.) Install the rest of the screws evenly in space provided. Make sure at least three screws are installed through the end cap front flap and of those three screws, at least one catches the last inch of the endcap towards the middle. In some situations, all of these screws will land in end cap front flap.
4. Lay the canopy top cover front flap with velcro over the newly installed curtain face and screws. Take care in positioning the flap so it is even along the front of the unit. This flap keeps the water from entering behind the front curtain.

# 610 Series C4-Style Curtain

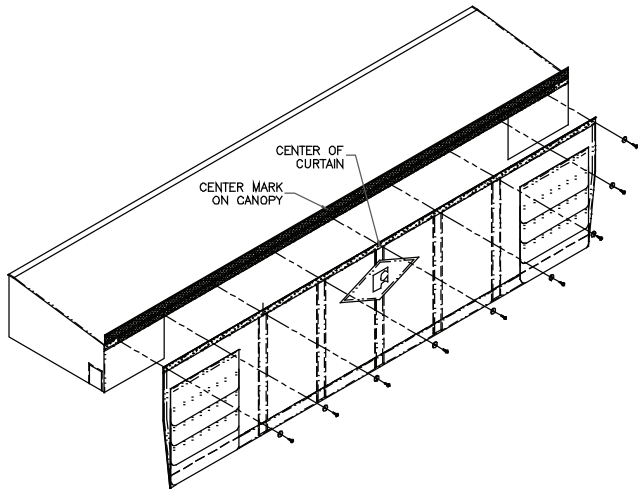

**FIGURE 1**

5. Install Windstraps - Reference Figure 2.

The first step requires cutting two vertical slits in the outside edge of the side curtain with a utility knife. If the slits are already present and at the correct location as described in Figure 1, this step can be skipped. Generally, the slits will only need to be cut during installation if you are installing a replacement head curtain.

## IMPORTANT!!!

**Cut through side curtain only. Do not cut through side pad cover.**

To do this, release the outboard flap of the side curtain from the side pads in the locations of the slits. Each slit should be 2" long. The center of the top slit should be located 3" below the top edge of the side curtain and 4 1/2" in from back edge of outboard flap. The lower slit should be located approximately 6" above the bottom edge of the head curtain and 4 1/2" in from back edge of outboard flap.

After the slits are cut, position the top velcro patch between the outboard flap of the side curtain and the velcro on the outside of the side pad. Make sure the patch is oriented such that the velcro on the side pad and the outboard flap of the side curtain will latch onto the velcro on the respective sides of the patch. The D-ring that is attached to the velcro patch should penetrate through the slit that was cut near the top of the side curtain.

The velcro patch with the bungee cord attached is positioned by the lower slit. It can be installed by feeding the hook end of the bungee cord through the slit from the back side of the curtain. Continue feeding the bungee cord through until the D-ring on the patch penetrates through the slit. Again, make sure the patch is oriented such that the velcro on the side pad and the outboard flap of the side curtain will latch onto the velcro on each side of the patch. Press the patch onto the velcro on the outboard flap of the side curtain and press the flap back down onto the side pad.

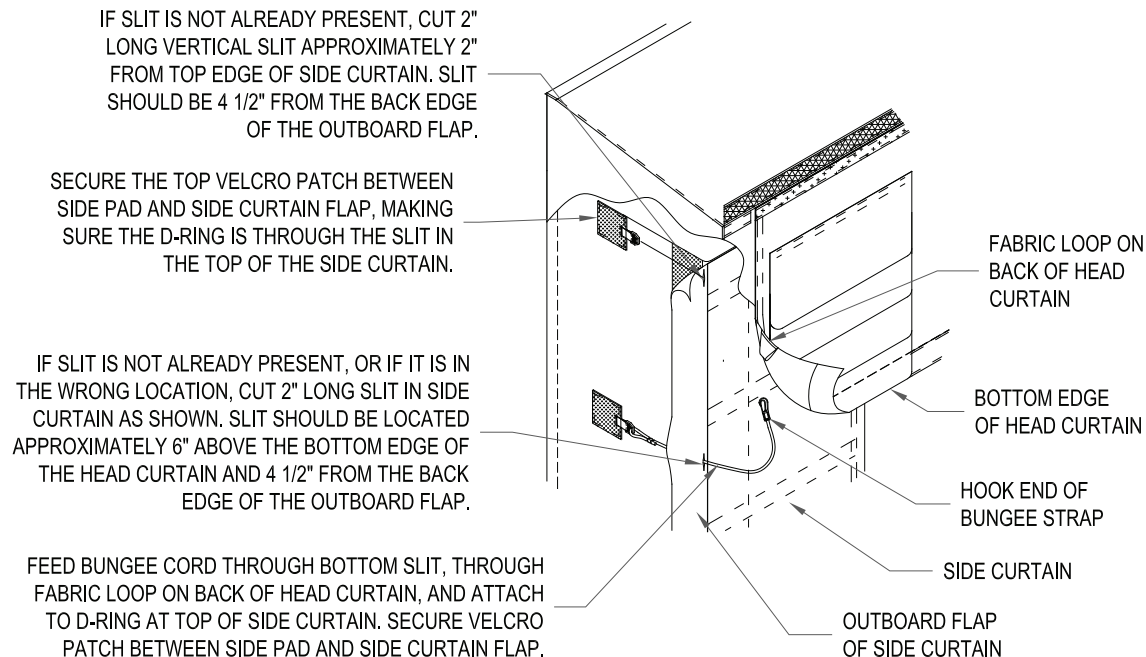

**FIGURE 2**

# 610 Series C4-Style Curtain

Feed the hook end of the bungee cord through the fabric loop on the back side of the head curtain.

Attach the hook on the bungee cord to the D-ring that is coming out the top slit.

Complete this procedure on both sides of the curtain.

## C4-Style Curtain (15'-4" Off-Grade and Over)

These instructions illustrate how to install a C4-Style curtain face mounted 15'-4" off grade and over on a stand alone unit and assumes that the header brackets are installed on side members. These instructions use part of the standard C4 Style curtain instructions seen above.

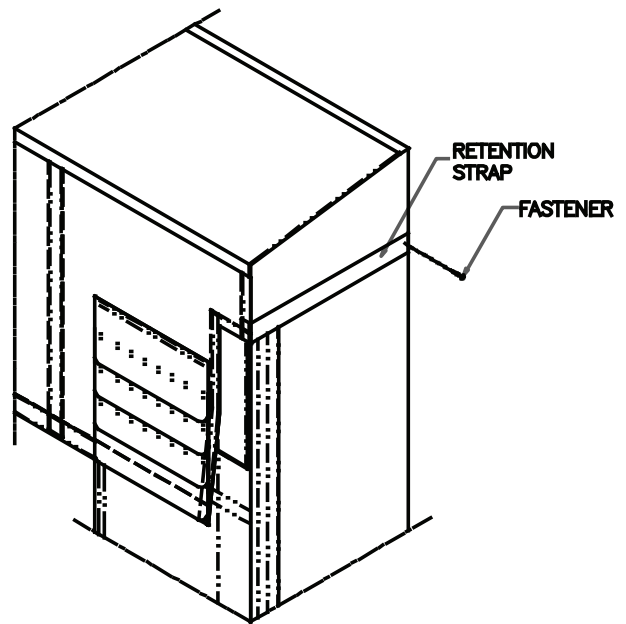

FIGURE 3

1. Located on the canopy top cover front flap is a small tab that locates the center of the unit. Marking this location makes it easier to install curtain face. **(Note: Verification of this location can be done by measuring across the top of the front of the unit and dividing this measurement by 2.)**
2. Line the curtain face up with the outside edges of the unit. (See Figure 3)
3. Using the velcro on the curtain face and velcro on the front bar, temporarily hang the curtain face from the canopy top cover. Make sure curtain face top edge is aligned with the front bar. There will be slight variations in the velcro location on the front bar, so make sure you align the two edges and not the velcro(s). Also, make sure that the curtain face is underneath the canopy top cover front flap and that it is centered on the mark made in the previous step. The middle stay on the C4 Style curtain face should align with the mark made in step 1.
4. Continue with final steps in the standard instructions for a "C4-Style Curtain" seen above, then return to Step 5 of these instructions. **(Note: More attachment screws and washers are required since curtain width is larger. Follow instructions, adding extra screws in spaces needed.)**
5. Once the curtain face is attached properly, finish by attaching the face retention strap to the side frame backer board. Use the supplied roofing nail. **(Note: If retention strap lands in area on header mounting bracket, attach using existing woods screws that secure mounting bracket to backer board, or use a tek-screw and attach to mounting bracket itself) Figure 2**

# 610 Series C4-Style Curtain

## C4-Style Curtain

(15'-4" Off-Grade and Over)  
Common Member

These instructions illustrate how to install a C4-style curtain face mounted 15'-4" off grade and over, is a common member on a stand alone unit and assumes that the header brackets are installed on side members.

1. Follow the instructions for a c4-style curtain face mounted 15'-4" off grade and over except follow Step 2 of these instructions instead of Step 5.
2. The common member ends of the curtain face will need to be attached to each other using the velcro sewn on at the factory. (See Figure 4)

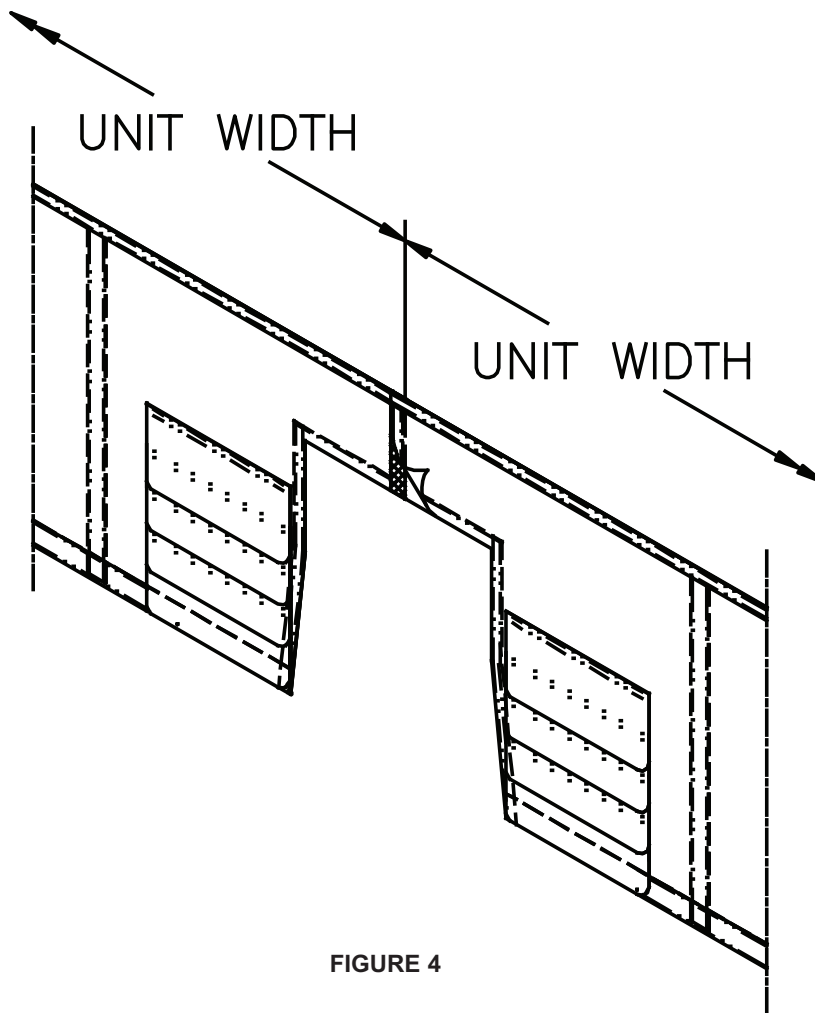

FIGURE 4

# 610 SERIES GUTTER ASSEMBLY

## Table of Contents

File Information	.I1
General Precautions	.I1
Introduction	.I1
Illustrations	.I1
Installation Instructions	.I1
Gutter Assembly	.I1-2

## File Information

Document Name:	5162-0004
Date Last Revised:	03/01/05
Revision Letter:	A

## General Precautions



**WARNING!!!**

Post safety warning and barricade work area, at dock level and ground level to prevent unauthorized use of the dock position while service work is being performed.

## Introduction

The following installation instructions are complete for all applications of the gutter option that are normally available. Any application of the gutter option that is outside of normal application guidelines, should be referred to Order Engineering for installation instructions. These instructions also assume that the installer is outside the building facing the loading dock position.

## Illustrations

Illustrations for this document are contained on drawing #5162.0005

## Installation

### Gutter Assembly

These instructions illustrate how to install a gutter assembly on a canopy style header. **(Note: Gutter goes underneath canopy flap) See Figure 2**

1. Before installing any of the screws that attach the curtain face, install only the center attachment screw for the curtain face. **(Note: Make sure the screw is centered on the bar or the gutter may get mounted to high.)** Do this without the gutter strip. This screw locates and temporarily holds the gutter strip in place during it's installation. (See Figure 1)
2. Now remove this screw. Locate the gutter strip center hole over the newly made hole from the tek-screw and screw in place. (See Figure 1) Before completely tightening the screw, rotate gutter strip into approximate parallel position to canopy front bar bottom edge. Then tighten the screw so it can hold gutter up, but take care in not stripping the screw out.

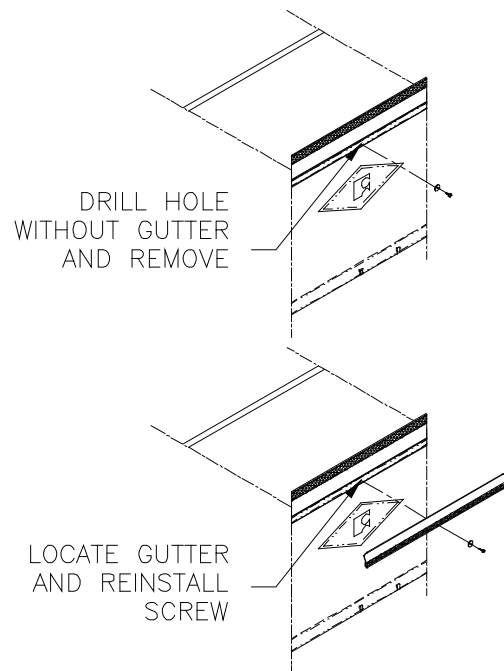

FIGURE 1

## 610 Series Gutter Assembly

2. Once the first tek-screw is in place, again align the gutter from side to side, parallel to the front bar bottom edge. (See Figure 2) Starting from center and going out in each direction, install the the first 2-3 screws into the holes already in the gutter strip that land on the marked locations determined in the curtain face installation instructions. Do not install screws past the this point. This makes sure that the gutter does not get misaligned and lays flat. (Note: Starting from the outside in, can create bulges in gutter plate.)
3. Once the screws are in place, install the remaining screws on the outside that land in end cap front flap area and at the end of the front curtain. Make sure that a tek-screw lands in the following locations:
  - one screw lands at the end of the front curtain on each side. Approximately 1" off edge.
  - one screws lands at last hole on gutter strip to hold it securely to front bar.
  - one screws lands approximately 1" from the end of end cap front flap to keep it from pulling down.
4. After all the tek-screws are installed, lay the top cover front flap with velcro over the newly installed gutter strip, curtain face and screws. (See Figure 2) Take care in positioning the flap so it is even along the front of the unit. Do not pull flap tight over gutter plate. It should fit correctly slightly loose and the velcro on flap should just cover and hide the bottom edge of gutter assembly by approximately 1/2". Also, the flap should not be too loose, so adjust its position as needed.

**(Note: Screws go behind canopy flap and are hidden, they are not to be installed on the outside of canopy flap).**

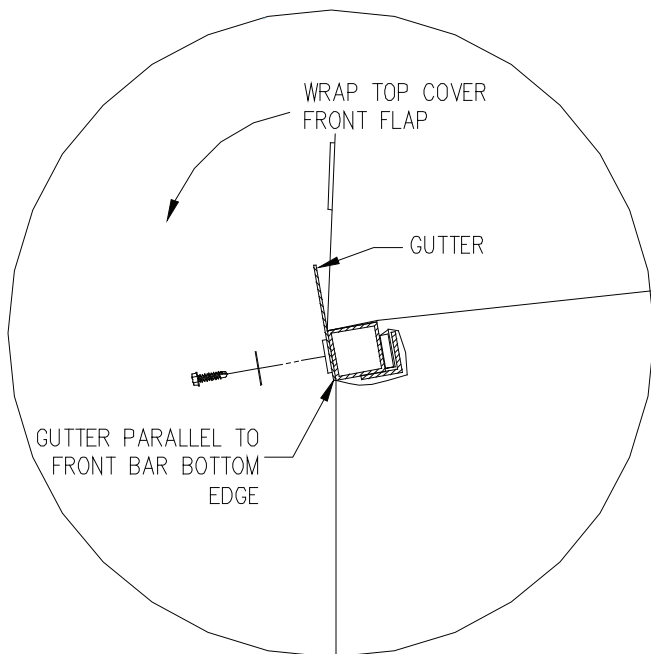

FIGURE 2

# 610 SERIES BUMPER

## Table of Contents

File Information	J1
General Precautions	J1
Introduction	J1
Illustrations	J1
Installation Instructions	J1
610 Series Bumper	J1

## File Information

Document Name:	1531-0002
Date Last Revised:	06/22/11
Revision Letter:	A

## General Precautions



**WARNING!!!**

Post safety warning and barricade work area, at dock level and ground level to prevent unauthorized use of the dock position while service work is being performed.

## Introduction

The following installation instructions are complete for all applications of the gutter option that are normally available. Any application of the gutter option that is outside of normal application guidelines, should be referred to Order Engineering for installation instructions. These instructions also assume that the installer is outside the building facing the loading dock position.

## Illustrations

Illustrations for this document are contained on drawing #1531-0003

## Installation: 610 Bumper

These instructions illustrate how to install a 610 Series bumper under a 610 Series Side Frame.

1. Bumper should be mounted to the foundation wall.
2. Position bumpers so that they are centered with the side frames, and located 1" - 2" below dock level. (See Figure 1)
3. Secure bumpers to the foundation wall with the

appropriate fasteners for the type of building they are being installed on. Use a minimum of (4) fasteners per bumper. See Fastening Methods section of this installation.

4. Install one bumper per side frame.

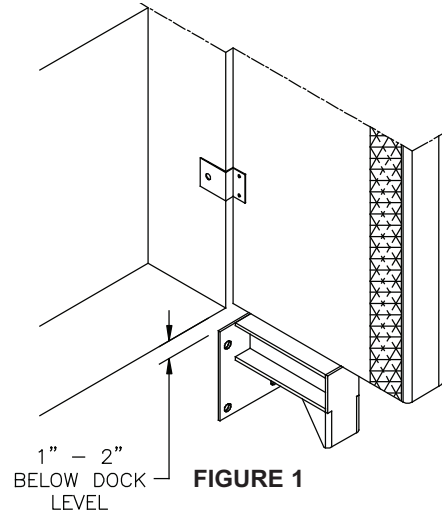

## Fastening Methods

### Concrete Block or Brick Wall

Through bolt fastening is required. Bore a hole through the building wall. Use a 3/8" diameter threaded rod with a washer, nut and jam nut on each end - it may be necessary to install a back-up plate inside the building wall when the wall will not support the bolt.

### Concrete Tilt-Up Walls (Precast)

Use a 3/8" lag bolt with expansion shields, 3/8" one piece anchor bolts with expansion collar, or equivalent fastener. If building wall is too thin to effectively hold the lag bolt or anchor bolt, the through bolt method of attachment is required.

\* See anchor manufacturer's recommendation for minimum anchor embedment to determine appropriate anchor length.

### Metal Side Building

Through bolt method of attachment is required for this building style. It will be necessary to install a back-up plate that is fastened directly to structural members when it is not possible to fasten directly to structural building members. Use a 3/8" diameter bolt with a washer and lock nut to fasten the unit to the structural members of the building or to the back-up plates. If necessary, use a 3/8" diameter threaded rod with a washer and lock nut on each end.

# COLLAPSIBLE STYLE DRAFT PAD

## Table of Contents

EGM draft pad pre-assembly.....	1
EGM draft pad installation.....	2

## File Information

Document Name: 4109-0004  
Date Last Revised: 07/11  
Revision Letter: B

## General Precautions



**WARNING!!!**

Post safety warning and barricade work area, at dock level and ground level to prevent unauthorized use of the dock position while service work is being performed

## Introduction

The following installation instructions are complete for all applications of the Collapsible Style Draft Pad that are normally available. Any application of the Collapsible Style Draft Pad that is outside of normal application guidelines, should be referred to Order Engineering for installation instructions. These instructions also assume that the installer is outside the building facing the loading dock position.

## Illustrations

Illustrations for this document are contained on drawing # 4109-0005

## Installation

### Retrofit panel installation:

If velcro attachment flap is not located on side pad cover, the use of a retrofit panel is required.

Install retrofit panel as shown in Figure 1. Rear edge should be screwed to side pad backer in 3 places. Front edge should be located between side pad cover and side curtain attachment flap.

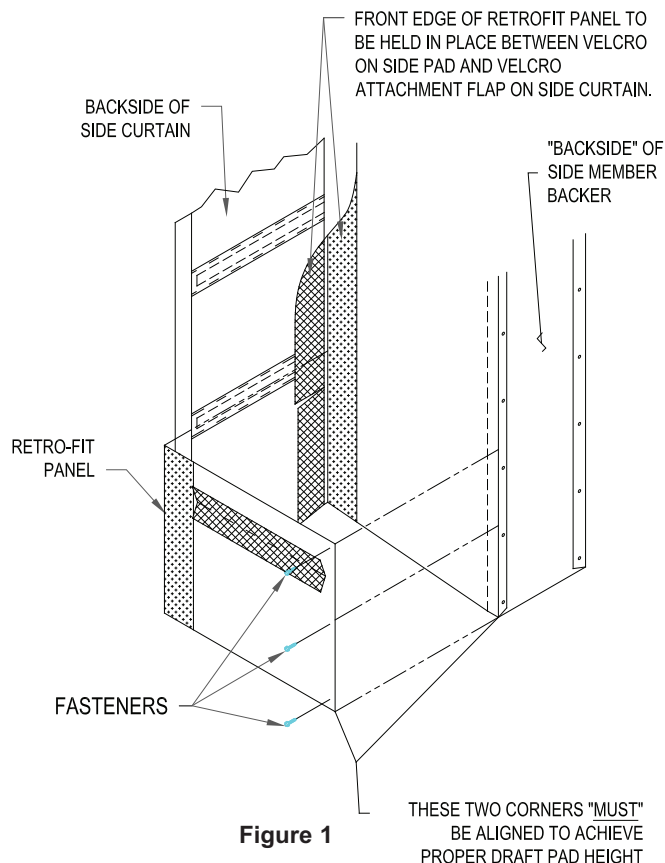

Figure 1

# Collapsible Style Draft Pad

## DRAFT PAD INSTALLATION:

1. Align velcro at top of draft pad with velcro flap on side member (and back of side curtain if applicable). Press velcro connections tightly closed.

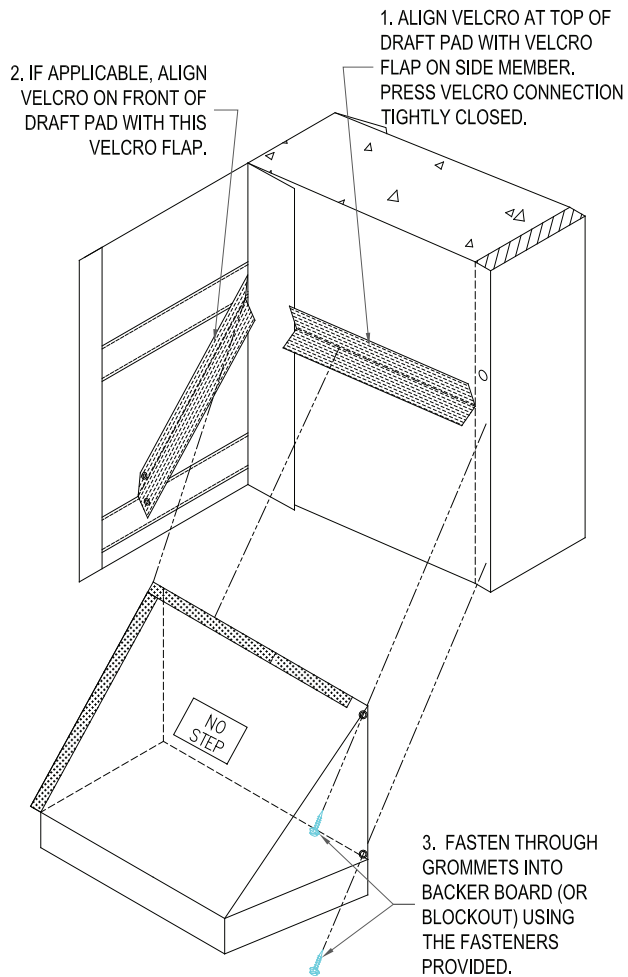

Figure 2

2. Fasten through grommets into backer board using the fasteners provided. See Figure 2.
- 3A. If there is not a velcro attachment flap on the back of the side curtain as shown in Figure 2, secure front edge of draft pad as shown in Figure 3. Installation is then complete.

- 3B. If there is a Velcro attachment flap on the back of the side curtain, align the Velcro along the front edge of the draft pad with the Velcro attachment flap on the back of the side curtain. Reference Figure 4.

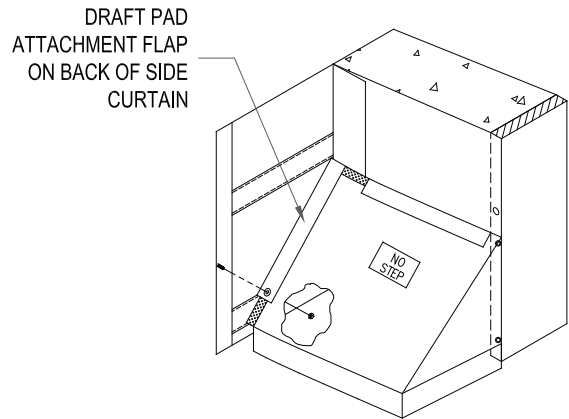

Figure 4

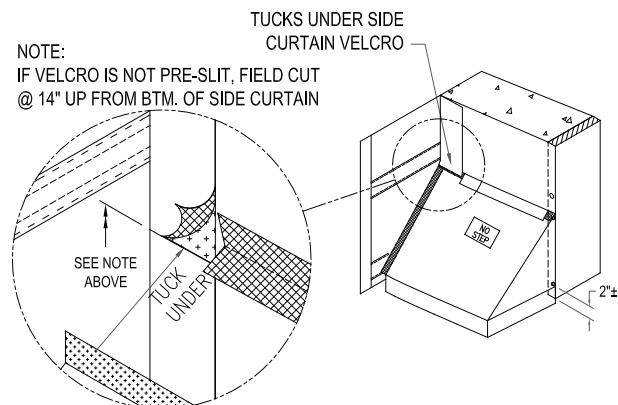

Figure 3

# OPTIONS INSERTED AS REQUIRED

---

## OPTIONS AVAILABLE FOR THIS UNIT:

HEADER BLOCKOUTS

SIDE FRAME BLOCKOUTS

FOAM BACKERS

FOAM BACKER BLOCKOUTS

\*Note these are included as required.

# NOTES

---

# NOTES

---

---

# **Frommelt®**

# **ELIMINATOR™ II- COMBOSHELTER™ II**

**610 Series**

**Installation Instructions & Owner's Manual**

**“Our mission is to improve industrial safety, productivity and security worldwide through quality and innovation.”**

**Frommelt Products Corporation**  
**A Rite-Hite® Company**

**8900 North Arbon Drive**  
**P.O. Box 245020**  
**Milwaukee, WI 53224-9520**