

FASTRAX[®] FR LD

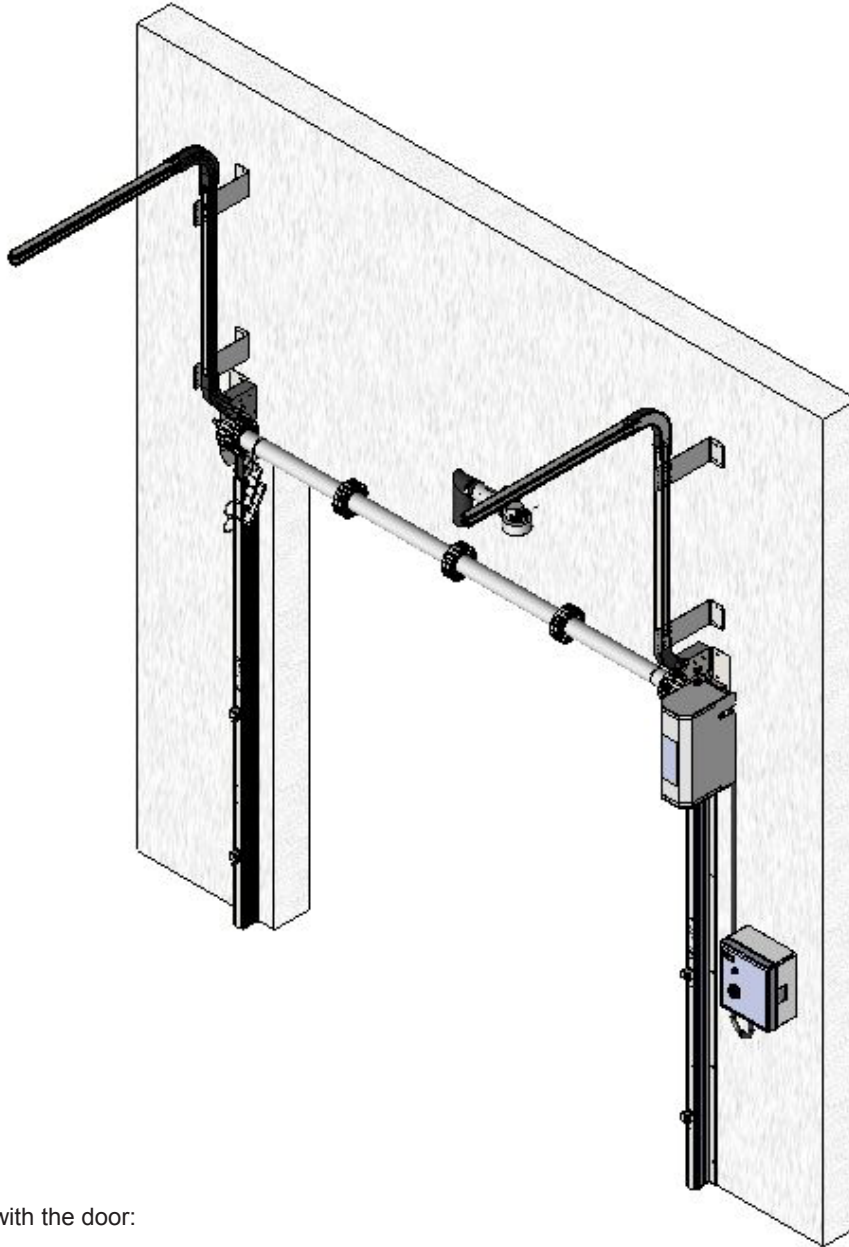

This manual to remain with the door:
Date Installed: _____



This Manual Covers All Doors Shipped To Date.

TABLE OF CONTENTS

CHAPTER 1

SUGGESTED MOUNTING METHODS 10
 DOOR JAMB 15
 POLY LUMBER (OPTIONAL)..... 17
 THERMAL AIR SEAL - SINGLE BLOWER..... 18
 THERMAL AIR SEAL - DUAL BLOWER 20

CHAPTER 2

LOWER TRACK INSTALLATION 21
 UPPER TRACK WRAP BACK 24
 UPPER TRACK VERTICAL LIFT 25
 UPPER TRACK HIGH LIFT 26
 UPPER TRACK STANDARD LIFT 28
 UPPER TRACK 45° TILT LIFT 30

CHAPTER 3

DRIVE TUBE INSTALLATION 31
 MOTOR / ENCODER INSTALLATION 32
 CURTAIN INSTALLATION 34

CHAPTER 4

ELECTRICAL INSTALLATION 37
 I-COMM II LOGIC CHART 41
 I-COMM II LAYOUT 42
 I-COMM ENCODER SETUP 43
 I-COMM ENCODER DISPLAY SETUP DESCRIPTIONS .. 45
 I-COMM DISPLAY MESSAGES 46
 I-COMM II FOLDERS 47
 I-COMM II INPUT / OUTPUT VALUES 49
 I-COMM FOLDERS 51
 I-COMM PROCEDURES 51
 230/460V INVERTER (VFD) PROGRAMMING 52
 230/460V INVERTER (VFD) CODES 53
 575V INVERTER (VFD) PROGRAMMING 55

CHAPTER 5

DOOR OPERATION 57
 FINAL CHECKLIST 59

CHAPTER 6

OPTIONAL BRAKE RELEASE / CHAIN HOIST 60
 OPTIONAL WELD PLATE INSTALLATION 62
 LABELS / I-ZONE / SHROUD 63

CHAPTER 7

MAINTENANCE PROCEDURES 64
 MAINTENANCE INFO 65
 MAINTENANCE ITEMS 65
 TROUBLESHOOTING 68

CHAPTER 8

ELECTRICAL CABLE IDENTIFICATION 71
 WIRELESS ACTIVATION 72
 OPTIONAL REMOTE MOUNTED CONTROLS 73

CHAPTER 9

MANDATORY FIELD WIRING DIAGRAM >43" O.D.H... 75
 MANDATORY FIELD WIRING DIAGRAM <43" O.D.H... 76
 230/460V ELECTRICAL WIRING DRAWING 77
 575V ELECTRICAL WIRING DRAWING 78
 ACTIVATION WIRING 79
 VIRTUAL VISION J-BOX 80
 VIRTUAL VISION ELECTRICAL DRAWING 81
 DEFROST JUNCTION BOX WIRING 208/230/460/575V...82
 ELECTRICAL DRAWING SINGLE BLOWER 120V 83
 ELECTRICAL DRAWING SINGLE BLOWER 220/400V .. 84
 ELECTRICAL DRAWING DUAL BLOWER 230/460V 85
 ELECTRICAL DRAWING DUAL BLOWER 120V 86
 ELECTRICAL DRAWING DUAL BLOWER 220/400V 87

CHAPTER 10

CONTROL BOX SERVICE PARTS 88
 DRIVE SYSTEM SERVICE PARTS 89
 MISC SERVICE PARTS 91
 CURTAIN SERVICE PARTS 92
 WRAP BACK & HARDWARE SERVICE PARTS 95
 AIR SEAL & WRAP BACK SERVICE PARTS 97
 JUNCTION BOX SERVICE PARTS 98
 ACTIVATION 99

CHAPTER 11

ARCHITECTURAL DRAWING DUAL BLOWER 101
 ARCHITECTURAL DRAWING WRAP BACK 102
 ARCHITECTURAL DRAWING VERTICAL 103
 ARCHITECTURAL DRAWING HIGH LIFT 104
 ARCHITECTURAL DRAWING STANDARD 105
 ARCHITECTURAL DRAWING 45° TILT 106

WARRANTY BACK PAGE

SPECIAL FEATURES

i-COMM™ Universal Controller	Adjustable Speeds
Heavy-Duty Industrial Materials	Encoder Positioning
No Springs, Pulleys or Weights	Virtual Vision
InsulMax Curtain with Auto Re-feed™	Powder Coated Materials
I-Zone™ Area Detection System	Soft-Edge™ Technology
Flexible "You Build It" Track Design	High Pressure Capability
DuraMax Curtain w/Auto Re-feed™	Pre-wired Control Cable

RECOMMENDED SERVICE PARTS

Fuse, 1 Amp, 250V, Time Delay	51000002 (2)
Fuse, 2 Amp, 250V, Time Delay	51000005 (2)
Kit, Drive Sphere, Qty 20	53700561 (1)
Photoeye Source	53700702 (1)
Photoeye Receiver	53700703 (1)
Encoder Kit, Gearbox, #50	53700784 (1)
Encoder Kit, Gearbox, #63	53700878 (1)
Kit, i-COMM ii, Replacement	53700860 (1)

NOTICE TO USER

Our mission is to “Improve Industrial Safety, Security and Productivity Worldwide Through Quality and Innovation.”

Thank you for purchasing the LiteSpeed™ door from RITE-HITE DOORS, INC. The FasTrax FR LD door is a unique fabric door that can fit most opening configurations while helping to keep different atmospheres separate.

This manual should be thoroughly read and understood before beginning the installation, operation or servicing of this door. This owners manual MUST be stored near the door.

Complete final checklist prior to leaving site. RITE-HITE DOORS, INC. reserves the right to modify the electrical and architectural drawings in this manual, as well as the actual parts used on this product, which are subject to manufacturing changes and may be different than shown in this manual. Due to unique circumstances with varying requirements, separate prints may be included with the unit. The information contained in this manual will allow you to operate and maintain the door in a manner which will insure maximum life and trouble free operation.

Your local RITE-HITE Representative provides the Planned Maintenance Program (P.M.P.) which can be fitted to your specific operation. If any procedures for the installation, operation, or maintenance of the LiteSpeed have been left out of this manual, are not complete, or if you have suggestions, contact RITE-HITE DOORS, INC. Technical Support at 1-563-589-2722.

LOCKOUT/TAGOUT PROCEDURES

The Occupational Safety and Health Administration (OSHA) requires, in addition to posting safety warnings and barricading the work area (including, but not limited to, trucking office and loading docks), that the power supply has been locked in the OFF position or disconnected. It is mandatory that an approved lockout device is utilized. An example of a lockout device is illustrated. The proper lockout procedure requires that the person responsible for the repairs is the only person who has the ability to remove the lockout device.

In addition to the lockout device, it is also a requirement to tag the power control in a manner that will clearly note that repairs are under way and state who is responsible for the lockout condition. Tagout devices have to be constructed and printed so that exposure to weather conditions, or wet and damp locations, will not cause the tag to deteriorate or become unreadable.

Rite-Hite does not recommend any particular lockout device, but recommends the utilization of an OSHA approved device (refer to OSHA regulation 1910.147). Rite-Hite also recommends the review and implementation of an entire safety program for the Control of Hazardous Energy (Lockout/Tagout). These regulations are available through OSHA publication 3120.

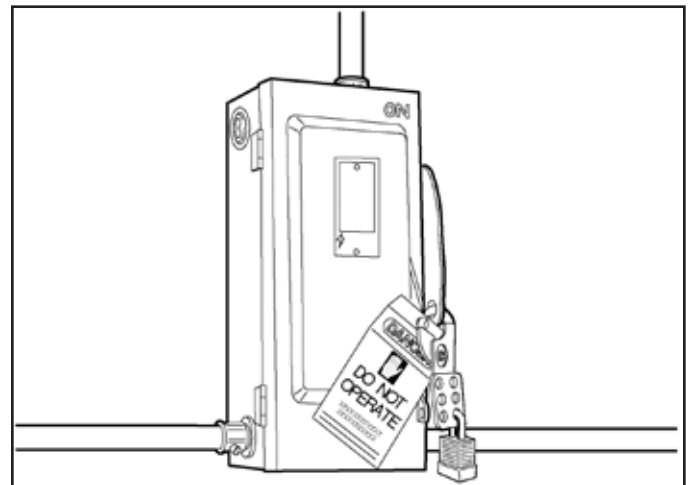

SAFETY WARNINGS

SAFETY IDENTIFICATION

DANGER

Danger indicates the presence of a hazard that *will cause severe personal injury or death.*

WARNING

Warning indicates the presence of a hazard that *can cause severe personal injury or death.*

CAUTION

Caution indicates the presence of a hazard that *will or can cause minor personal injury.*

NOTICE

Notice communicates installation, operation, or maintenance information that is safety related but not hazard related and may cause equipment or property damage.

NOTE: A Note is used to inform you of important installation, operation, or maintenance information.

GENERAL SAFETY ALERTS

DANGER

A qualified electrician should install the wiring in accordance with local and national electrical codes.
Use lockout and tagout procedures to prevent death or severe personal injury.

DANGER

When working with electrical or electronic controls, make sure that the power source has been locked out and tagged according to OSHA regulations and approved local electrical codes.

DANGER

To reduce risk of injury or death, an earth ground connection **MUST BE** made to the green/yellow control box ground terminal.
If metal conduit is used as the ground connector, an N.E.C. approved ground bushing and green/yellow wire **MUST BE** properly attached to the conduit for connection to the ground terminal.

WARNING

Failure to restrict the curtain speed can result in damage to product or injury to personnel. The curtain may close very quickly if the brake is fully released.
Releasing the brake partially will allow the door to close smoothly.

! CAUTION

To prevent unauthorized use, barricade the door opening on both sides until the door has been completely installed.

NOTICE

Be extremely careful when drilling conduit holes into the control box. Drilling too deeply or allowing debris to fall into electrical components may cause severe equipment damage or component failure.

DO NOT turn control box upside down when drilling holes. Holes on top of control box may allow dust and moisture to enter the control box.

The safest location for conduit is at the bottom of the control box. Failure to install conduit at the bottom of the control box may void the warranty.

NOTICE

In freezer and cooler applications where a conduit passes from a warm to cold temperature zone, the conduit must be sealed with an approved material per 300.7(a) of the National Electric Code (NFPA 70).

It is important to verify the following basic information before starting with the installation.

1. Alternate dimensions in brackets are in [millimeters].
2. Make sure that you are working at the correct location and that you have the required work permits.
3. Inspect the site to make sure that there are no overhead obstructions (sprinkler pipes, air handling systems, electrical supply lines, etc.) that might interfere with the installation.
4. Detour material handling equipment during the installation.
5. Make sure that the correct electrical power is supplied to the door control box and can be shut off without interfering with other plant operations.
6. In the case of multiple doors being installed, it is imperative to install the proper control box with the matching door unit. The serial # for your door is on a label located on the side of the control box and lower track, **“Figure 4–2” on page 39.**
7. Install activation and optional equipment after verifying door operation.
8. To verify proper installation, use **“Final Checklist” on page 59.**

NOTE: Electrical prints included in the parts or control box supersede any prints included in this owners manual on **page 75—page 87.** Always check for electrical prints.

! DANGER

Un électricien qualifié doit installer le câblage conformément aux codes électriques locaux et nationaux. Utilisez procédures de cadenassage et d'étiquetage d'interdiction pour éviter des blessures graves ou la mort.

! DANGER

Pour réduire le risque de blessure ou de décès, une connexion de mise à la terre doit être faite au vert/jaune borne de masse du boîtier de commande. Si conduit métallique est utilisé comme le connecteur de mise à la terre, un N. E. C. sol approuvé la bague et fil vert/jaune doit être correctement relié à la conduite à la borne de connexion de terre.

! DANGER

Lorsque vous travaillez avec électrique ou commandes électroniques, assurez-vous que la source d'alimentation a été verrouillé et étiqueté conformément aux réglementations de l'OSHA et approuvées codes électriques locaux.

! AVERTISSEMENT

Le non-respect de restreindre le rideau vitesse peut entraîner des dommages au produit ou blesser le personnel. Le rideau peut fermer très rapidement si le frein est complètement desserré. Relâchant le frein partiellement permettra à la porte pour la fermer sans heurts.

! ATTENTION

Pour empêcher toute utilisation non autorisée, barricade l'ouverture des portes des deux côtés jusqu'à ce que la porte a été complètement installé.

NOTICE

Être extrêmement prudent lors du perçage de trous dans le boîtier de commande. Perçage trop profondément ou permettant aux débris d'automne en composants électriques peut provoquer de graves dommages à l'équipement ou la panne d'un composant. **NE PAS** tourner la commande case à l'envers lors du perçage des trous. Les trous sur le haut de la boîte de commande peut permettre à la poussière et à l'humidité d'entrer dans le boîtier de commande. La plus sûre pour emplacement conduit est au bas de la boîte de commande. Échec de l'installation conduit au bas de la boîte de commande peut annuler la garantie.

NOTICE

Dans un congélateur et d'un refroidisseur applications où une conduite passe d'un chaud froid de zone de température, le conduit doit être scellé avec un matériau approuvé par 300,7 (a) du Code électrique national (NFPA 70).

CHAPTER 1

SUGGESTED MOUNTING METHODS

Acceptable Anchor Types

These anchor types provide the necessary strength for secure attachment of the unit to the building wall.

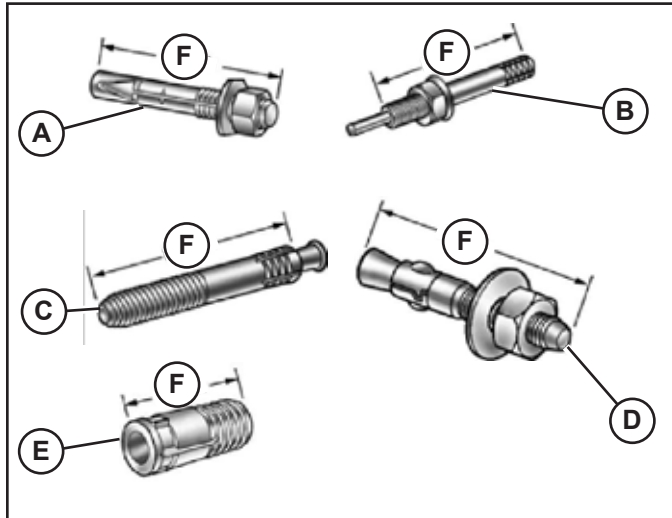

A - Sleeve Anchor	D - Wedge Anchor
B - Hammer Anchor	E - Expansion Anchor
C - Stud Anchor	F - Length

NOTE: Length (F) of anchor should be long enough to engage concrete structure by a minimum of 2" [51 mm]. Length should be increased to allow anchor to extend through any brick or aggregate surface on exterior into concrete structure by a minimum of 2" [51 mm].

Unacceptable Anchor Types

These anchor types are not strong enough for this application and do not provide the ability to tightly secure the unit to the building wall.

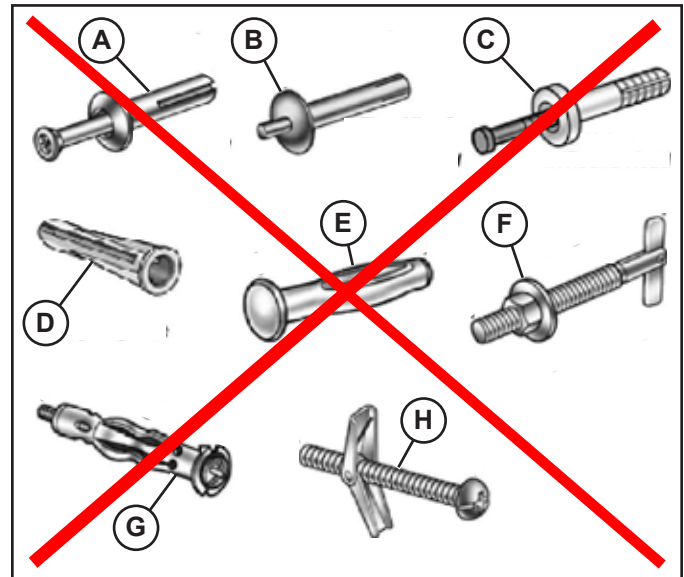

A - Removable Zinc Alloy	E - Split Drive Anchor
B - Zinc Alloy & Aluminum w/Wide Head	F - Threaded Toggle Anchor
C - Nylon w/Round Head	G - Hollow Wall Anchor (Molly Bolt)
D - Conical Polyethylene	H - Toggle Bolt

Figure 1-1

Acceptable Fasteners

Threaded rod can be used and cut to length in the field to suit the application. Hex head bolts can be used, but length must be determined ahead of time to ensure the fasteners will work with the application.

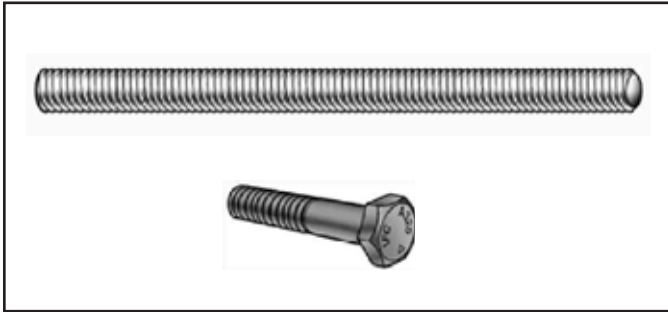

Figure 1-2

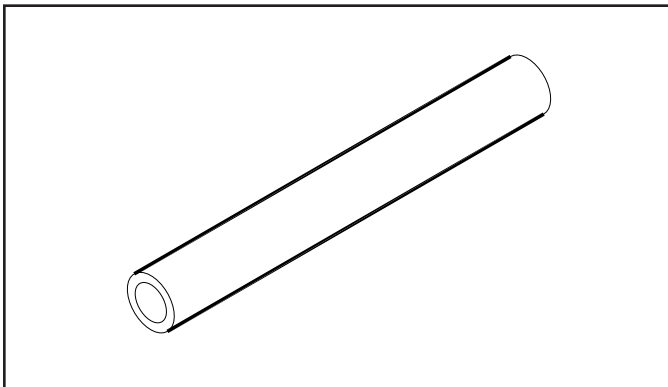

Figure 1-3: Wall Sleeve - 3/8" [10 mm] ID Ø

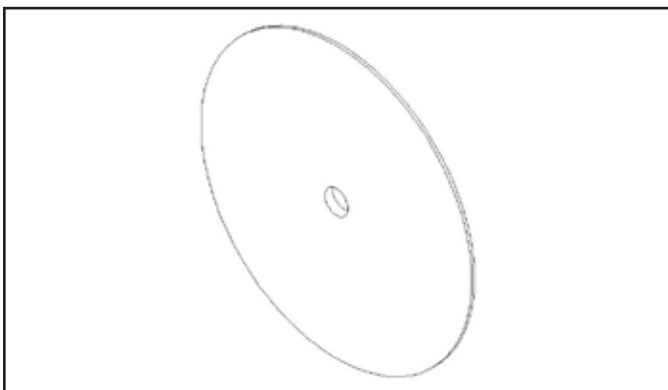
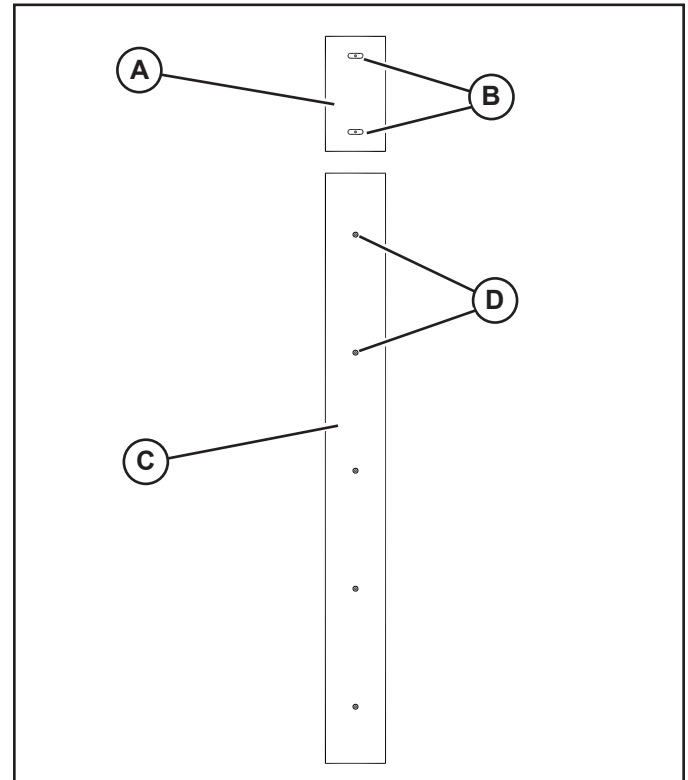

Figure 1-4: Backing Plate - 1/8" [3 mm] x 6" [152 mm] Ø

Typical Fastener Spacing



<i>A - Header</i>	<i>B - 3/8" [10 mm] Minimum fastener</i>
<i>C - Lower track</i>	<i>D - Lower track Fasteners</i>

Figure 1-5

If the wall is constructed of wood, stone block or insulation, follow this fastening method. Typically lower tracks on doors are required to be thru-bolted a minimum of every 4' [1219 mm] with lag screws filling in the remaining holes. Should a door fail to open when a vehicle is approaching the non-mounted side and impact the door, the fastening method must hold to prevent the door from coming off the wall. This is the responsibility of the installer.

Lower track requires 1/4" [6 mm] minimum fasteners (D) with thru-bolts a minimum of every 4' [1219 mm]. Wall sleeves (Figure 1-3) and Backing Plates (Figure 1-4) may be required if wall crushes when fasteners are tightened.

FASTRAX® FR LD

Block Wall

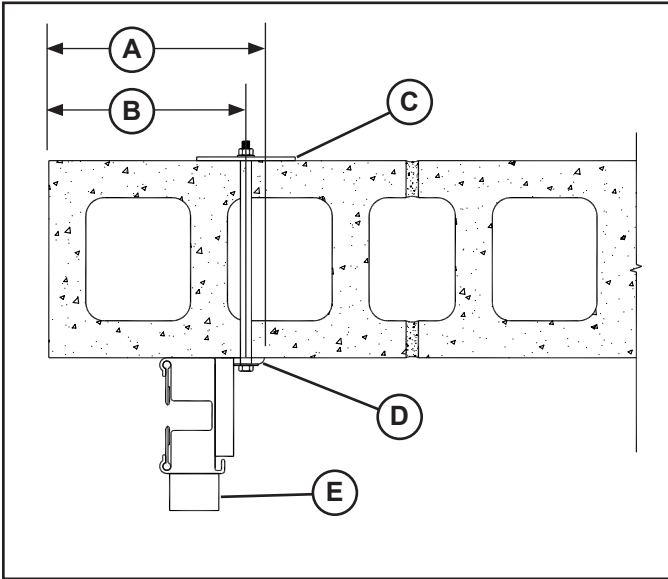

A - 8 3/4" [222 mm] Flat Space Required

B - 8" [203 mm]

C - Minimum 1/8" x 6"ø [6x152 mm] Backer Plate (Supplied by Others)

D - Minimum Fasteners Required
 3/8" [10 mm] for Header Bracket
 1/4" [6 mm] for Lower track
 Fasteners (Supplied by Others)

E - Lower track

Ribbed Metal Wall

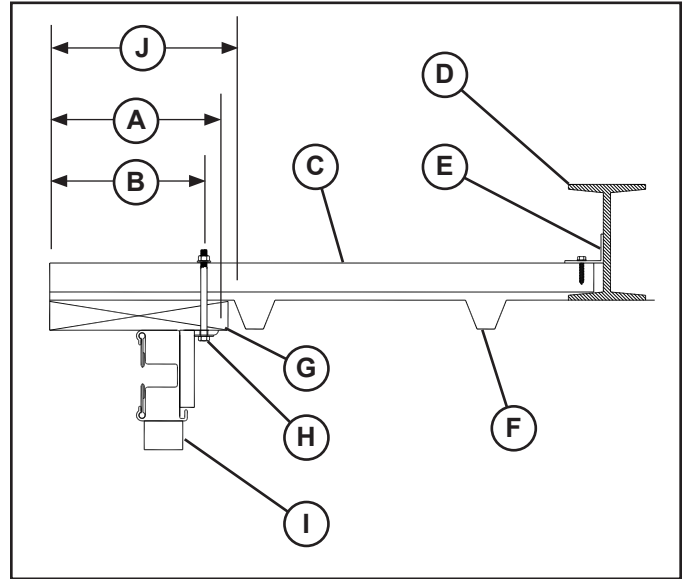

A - 8 3/4" [222 mm] Flat Space Required

B - 8" [203 mm]

C - 2"x6" [51x152 mm] or Structural Steel Channel Backer (Supplied by Others)

D - Building Structural Member

E - Angle Bracket (Supplied by Others)

F - Corrugated Metal Siding

G - Filler Board Ordered Through Rite-Hite or Supplied by Others

H - Minimum Fasteners Required
 3/8" [10 mm] for Header Bracket
 1/4" [6 mm] for Lower track
 Fasteners (Supplied by Others)

I - Lower track

J - 23" [584 mm] - Approximate flat space required for motor assembly install

Insulated Panel Wall

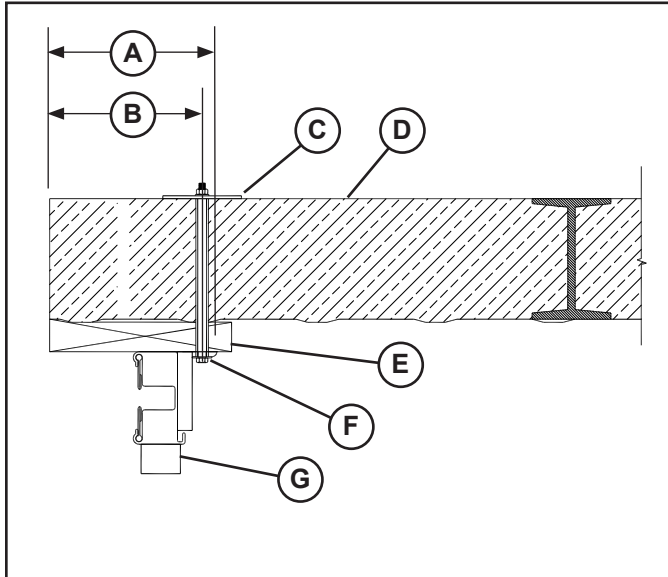

<i>A - 8 3/4" [222 mm] Flat Space Required</i>
<i>B - 8" [203 mm]</i>
<i>C - Minimum 1/8" x 6"ø [6x152 mm] Backer Plate (Supplied by Others)</i>
<i>D - Insulation</i>
<i>E - Filler Board Ordered Through Rite-Hite or Supplied by Others</i>
<i>F - Minimum Fasteners Required 3/8" [10 mm] for Header Bracket 1/4" [6 mm] for Lower track Fasteners (Supplied by Others)</i>
<i>G - Lower track</i>

Drywall

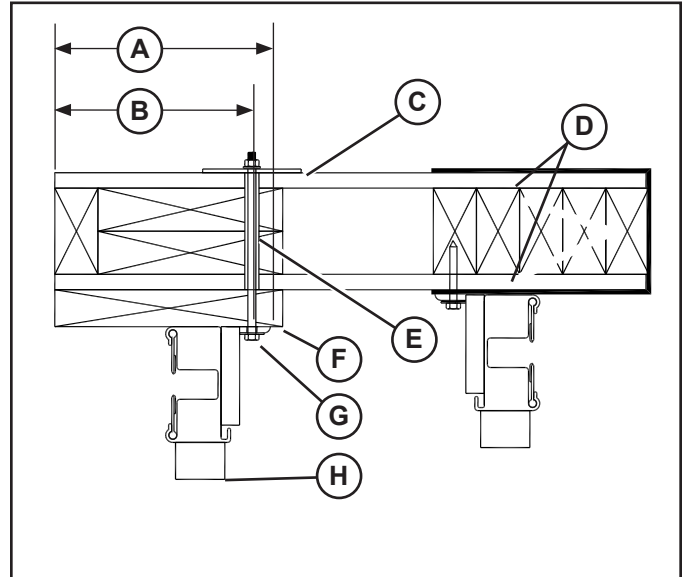

<i>A - 8 3/4" [222 mm] Flat Space Required</i>
<i>B - 8" [203 mm]</i>
<i>C - Minimum 1/8" x 6"ø [6x152 mm] Backer Plate (Supplied by Others)</i>
<i>D - Drywall</i>
<i>E - Wall Sleeve</i>
<i>F - Filler Board Ordered Through Rite-Hite or Supplied by Others</i>
<i>G - Minimum Fasteners Required 3/8" [10 mm] for Header Bracket 1/4" [6 mm] for Lower track Fasteners (Supplied by Others)</i>
<i>H - Lower track</i>

FASTRAX® FR LD

Concrete Wall

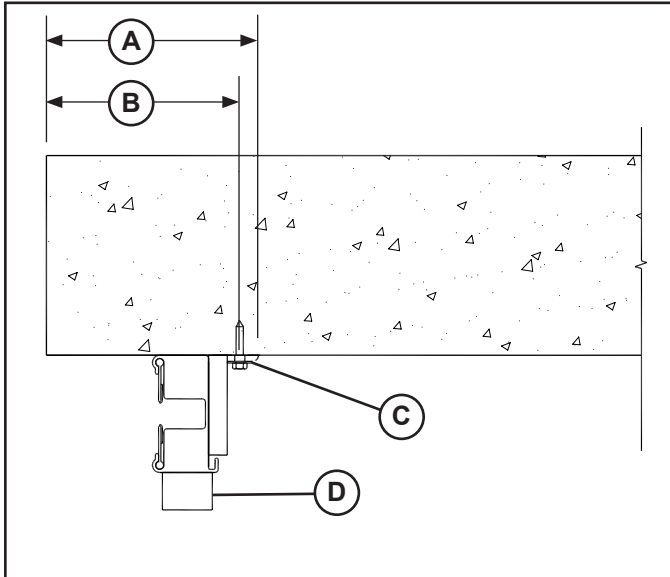

A - 8 3/4" [222 mm] Flat Space Required

B - 8" [203 mm]

*C - Minimum Fasteners Required
3/8" [10 mm] for Header Bracket
1/4" [6 mm] for Lower track
Fasteners (Supplied by Others)*

D - Lower track

Steel Member

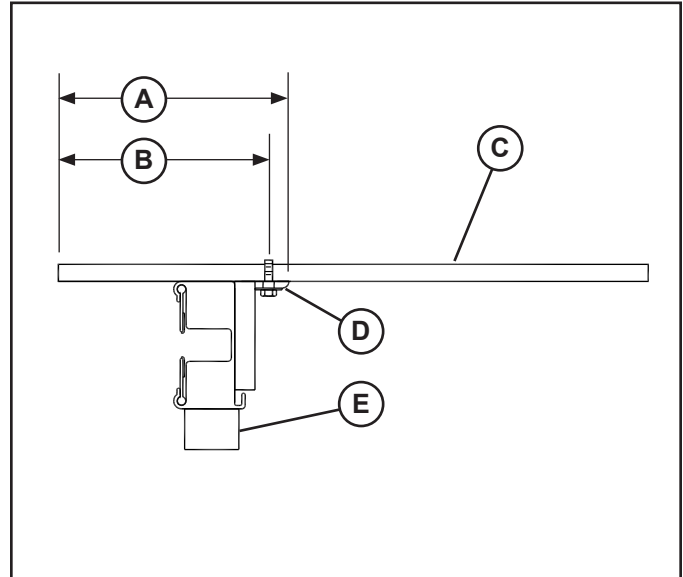

A - 8 3/4" [222 mm] Flat Space Required

B - 8" [203 mm]

C - 5/16" [8 mm] Minimum Steel Member

*D - Minimum Fasteners Required
3/8" [10 mm] for Header Bracket
1/4" [6 mm] for Lower track
Fasteners (Supplied by Others)*

E - Lower track

DOOR JAMB

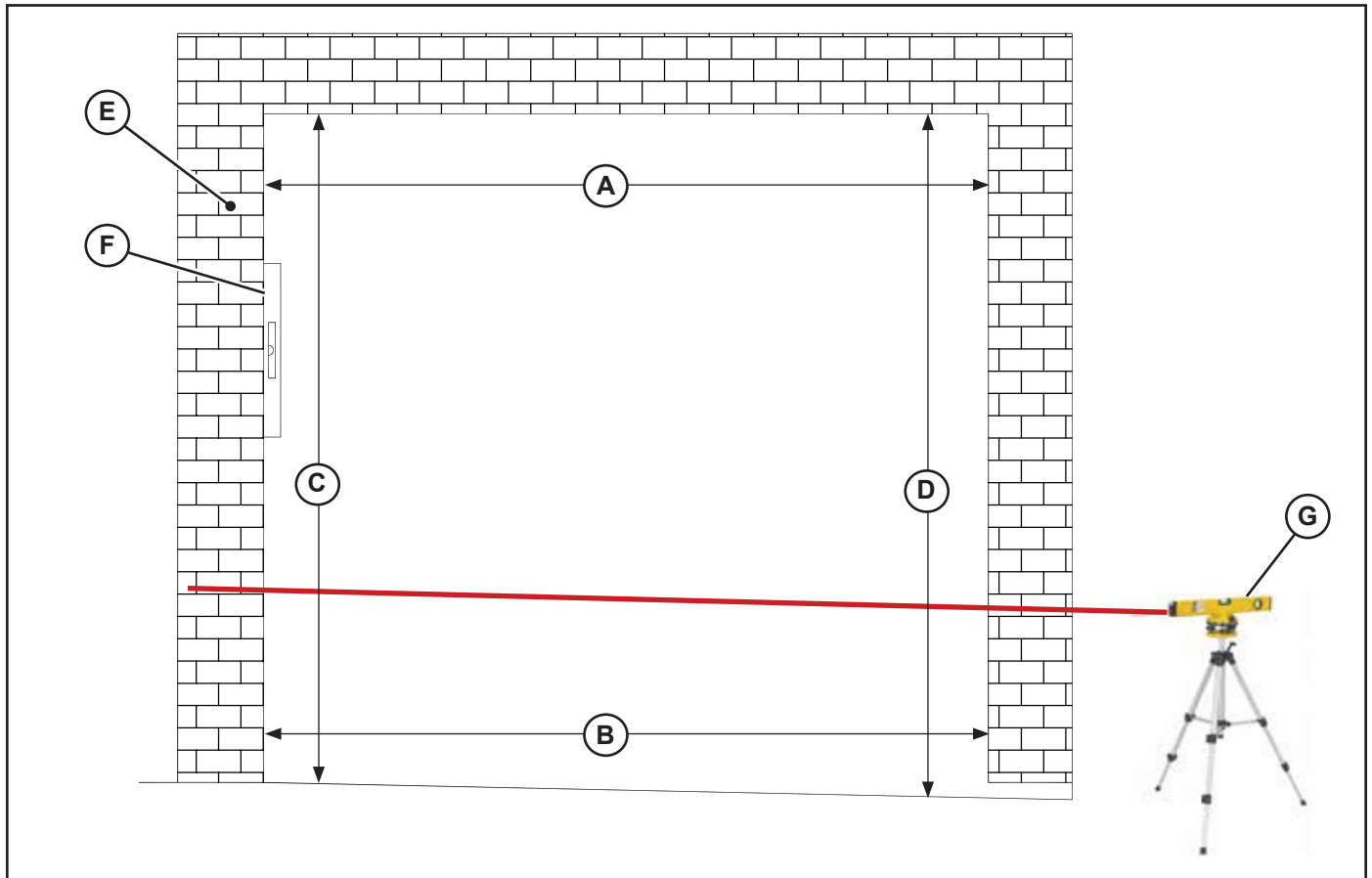

Figure 1-6

NOTE: For space clearance requirements, see Architectural Drawings on [pages 101–106](#).

1. Measure door opening width at the top (A).
2. Measure door opening width at the floor (B).
3. Measure door opening height at left side (C). In the diagram above, this is the “High Side.”
4. Measure door opening height at right side (D). In the diagram above, this is the “Low Side.”
5. Dimensions from steps 1–4 should be within $\pm 1/2$ ” [13 mm] of the dimensions listed on the serial number label. If the measurements do not agree, STOP! Contact your **RITE-HITE** representative.
6. Surface (E) MUST be flat, smooth and collinear with opposite side.
7. Using a 6’ [1829 mm] carpenter’s level (F), verify that the door jambs and header are plumb and perpendicular.
8. Using a laser level (G), place a mark where the laser is sighted on each side of the jamb to determine if the floor is level. Measure both sides from floor to the mark and if the floor is not level to within $1/8$ ” [3 mm], shim under the lower track that will be located on the “Low Side” (greatest measurement) of the door opening.

FASTRAX® FR LD

INSTALLATION TOOLS REQUIRED

25' [7620 mm] Tape measure	Laser Level
6' [1829 mm] Carpenters level	Ladder (6'–8') [1829 mm—2438 mm]
Scissors Lift	Plumb Bob
"C" Clamps	Hammer Drill
Drill (cordless or electric)	Drill Bits
Phillips Bit for Drill	Straight Edge
Wire Strippers	5/16" [10 mm] Nut Driver
Small Straight/Phillips Screwdrivers	Allen Wrench Set (2 mm, 1/8" [3 mm] & 5/32" [4 mm])
7/16" [11 mm], 1/2" [13 mm], 9/16" [14 mm], 3/4" [19 mm] Socket/wrench	

NOTICE

It is imperative that the tracks be mounted at the proper width.

If mounted too wide, excess wear is placed on the drive spheres.

If too narrow, the curtain may appear wavy or crease in the center.

NOTE: If door is equipped with Weld Plate option, proceed to [page 62](#).

POLY LUMBER (OPTIONAL)

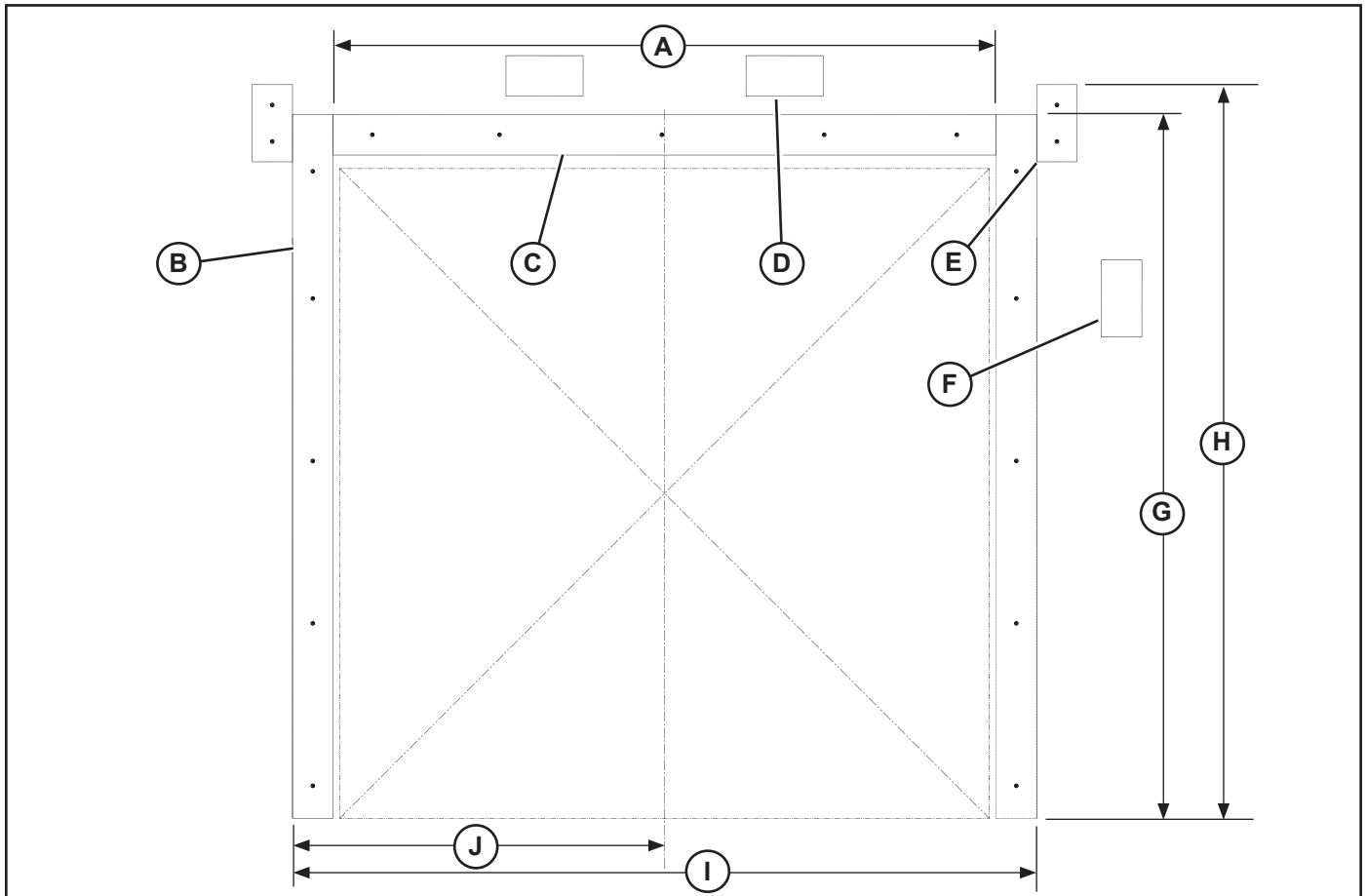

Figure 1-7

Reference dimension (A) = Ordered Door Width + 2 1/2" [64 mm].

1. (J) Measure 1/2 Ordered Door Width + 8 3/4" [222 mm].
2. (I) Measure Ordered Door Width + 17 1/2" [445 mm].
3. (G) Measure Ordered Door Height + 13" [330 mm].
4. (H) Measure Ordered Door Height + 15 1/2" [394 mm].
5. Caulk behind vertical poly lumber pieces (B) to prevent air transfer.
6. Caulk behind horizontal poly lumber (C) and install for lintel seal and lintel rollers.
7. Install short poly lumber pieces (E).
8. Install short piece(s) of poly lumber (D) for the air seal heater.
9. Install short poly lumber piece (F) for chain hoist.

THERMAL AIR SEAL - SINGLE BLOWER

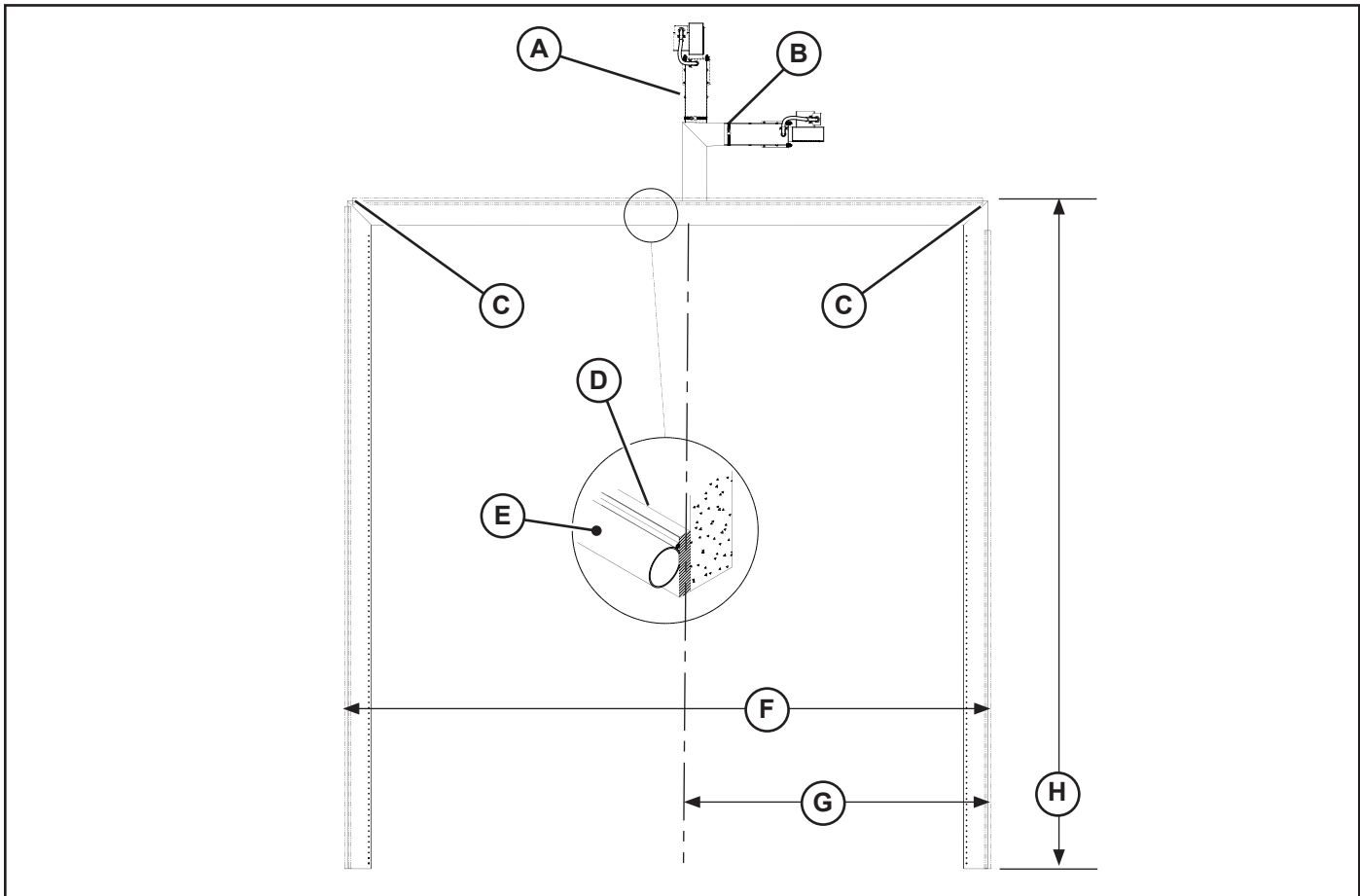

Figure 1-8

1. (G) Measure outside edge of aluminum retainer $1/2$ O.D.W. + 4 $1/2$ " [114 mm].
2. (F) Measure Ordered Door Width + 9" [229 mm].
3. (H) Measure outside edge of aluminum retainer at O.D.H. + 13" [330 mm]
4. Using hardware provided, fasten aluminum retainer (D) with thermal seal (E) to the poly lumber or wall.
5. (B) Clamp blower to air seal outlet with cable ties. Assure vertical section is tight and kink free to maintain proper air flow.

IMPORTANT !!!! Screws (C) MUST be in Place at Corners to Prevent Air Seal From Migrating.

Thermal Air seal outlet (A) is high temp fabric. Do not replace or add to it. If need be, the 90° elbow can be removed and the blower mounted vertically.

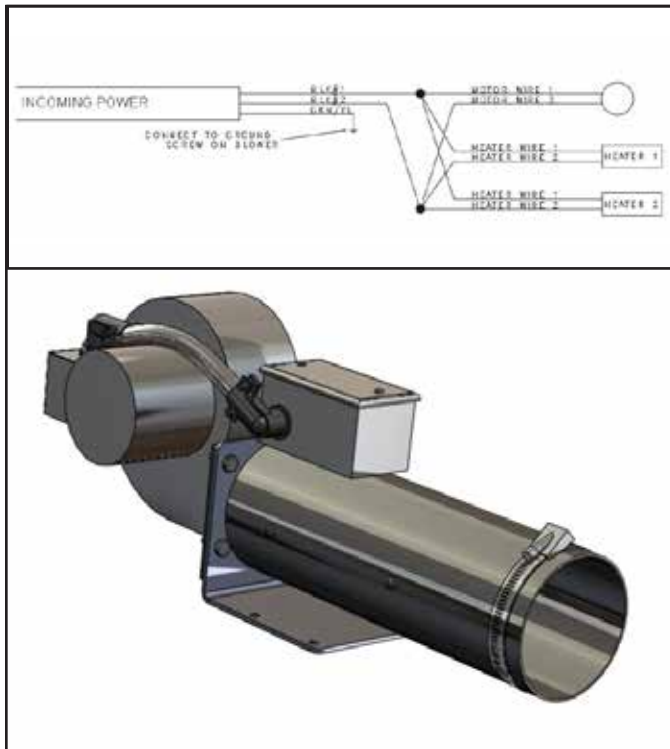

Figure 1-9: Thermal Air Seal Blower Installation

6. Fasten blower to the air seal and to the wall, and wire blower.

NOTICE

**Surface of tube can be hot.
Avoid contact.**

NOTICE

The Thermal Air Seal Blower should only be used when attached to a Rite-Hite air seal.

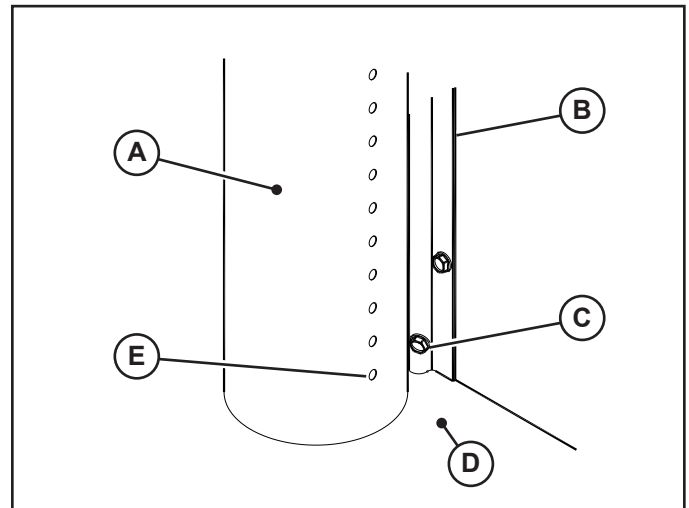

A - Air Seal
B - Rail
C - Fastener
D - Floor
E - Perforated Air Seal Holes

Figure 1-10

7. Caulk behind rail to prevent air infiltration.
8. Verify fastener thru retainer and seal rope.

NOTE: Heater / Blower must be permanently connected to power supply. Installer must supply wiring materials. (See drawing)

SPECIFICATIONS:

Self contained heater provides fan forced heat to a door perimeter seal.

Indoor Use Only

Part Number: 110V - 53700760

Part Number: 220V - 53700761

Part Number: 110V Canada - 53700783

Model: PTC

Voltage: 110 or 220V AC

Phase: 1

Frequency: 60 Hz

Power Consumption: 1450W

UL Listed - File E336487

[Drawing 7822E025]

THERMAL AIR SEAL - DUAL BLOWER

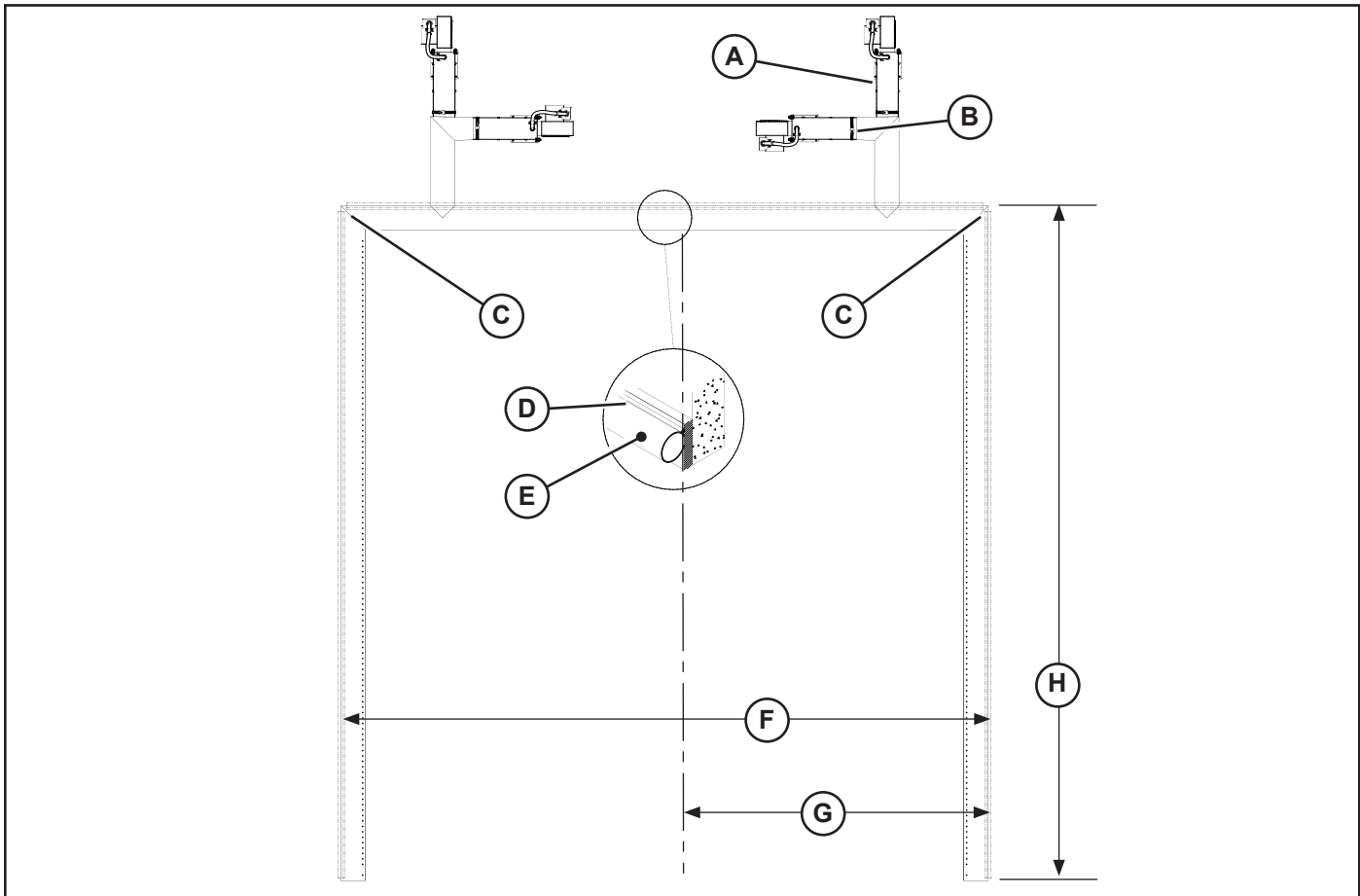

Figure 1-11

1. (G) Measure outside edge of aluminum retainer $1/2$ O.D.W. + $4\ 1/2$ " [114 mm].
2. (F) Measure Ordered Door Width + 9" [229 mm].
3. (H) Measure outside edge of aluminum retainer at O.D.H. + 13" [330 mm]
4. Using hardware provided, fasten aluminum retainer (D) with thermal seal (E) to the poly lumber or wall.
5. (B) Clamp blower to air seal outlet with cable ties. Assure vertical section is tight and kink free to maintain proper air flow.

IMPORTANT !!!! Screws (C) MUST be in Place at Corners to Prevent Air Seal From Migrating.

Thermal Air seal outlet (A) is high temp fabric. Do not replace or add to it. If need be, the 90° elbow can be removed and the blower mounted vertically.

CHAPTER 2

LOWER TRACK INSTALLATION

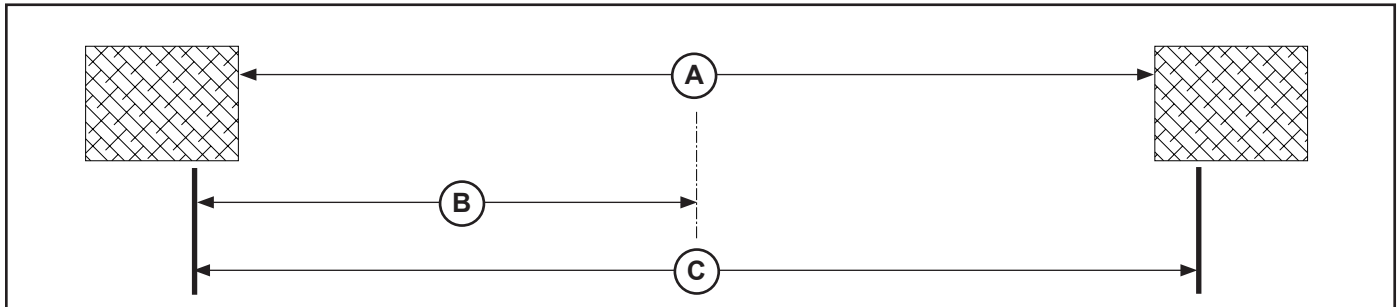

Figure 2-1

1. Measure Door Opening Width (A), find center, and place mark on the floor.
2. From centerline, measure over 1/2 Ordered Door Width + 4 1/2" [114 mm] (+ 1/16" [1.5 mm], - 0") (B) and place a mark on the floor.
3. From this mark, measure over Ordered Door Width + 9" [229 mm] (+ 1/8" [3 mm], -0") (C) and place a mark on the floor.

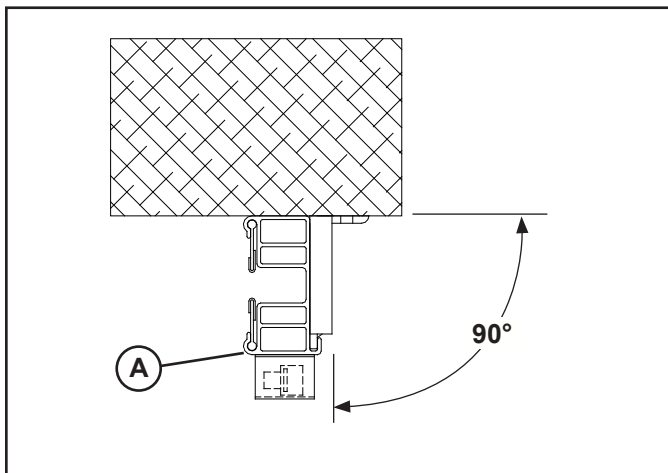

Figure 2-2

4. Place drive side lower track at the previously made mark on the floor.
5. Lower track must be 90° to wall. Measure the angle from the front edge of the lower track (A). Use shims as required to square the track. If possible, clamp the track in place.
6. Using a 6' [1829 mm] level, make sure that the track is plumb in both directions.

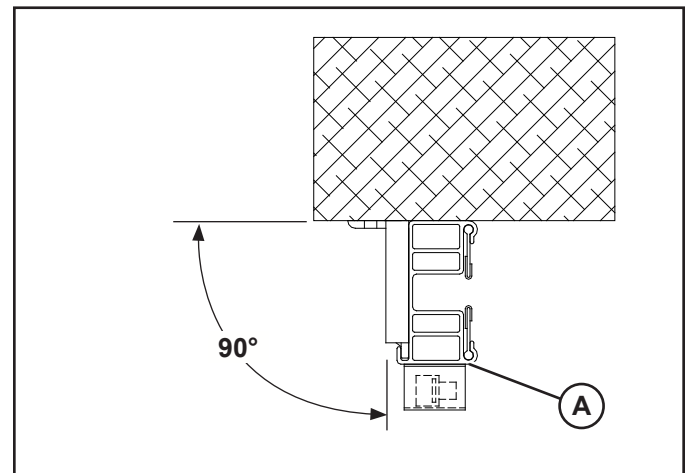

Figure 2-3

7. Place non-drive side lower track at the previously made mark on the floor.
8. Lower track must be 90° to wall. Measure the angle from the front edge of the lower track (A). Use shims as required to square the track. If possible, clamp the track in place.
9. Using a 6' [1829 mm] level, make sure that the track is plumb in both directions.

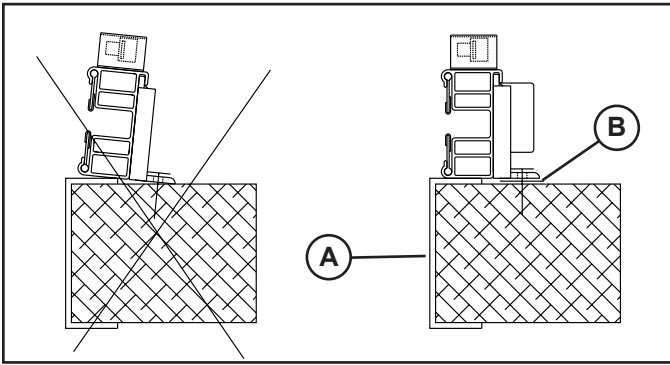

Figure 2-4

10. If wall has a jamb cap (A), shim behind the lower track (B).

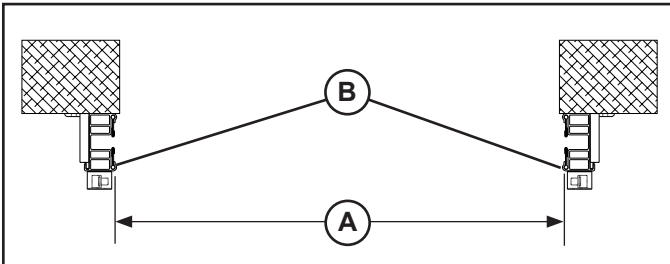

Figure 2-5

11. **Verify Critical Dimension (A):** Ordered Door Width plus 1/2" [13 mm] (+ 1/8" [3 mm], -0"). Take this measurement from the front edge of the lower tracks (B).

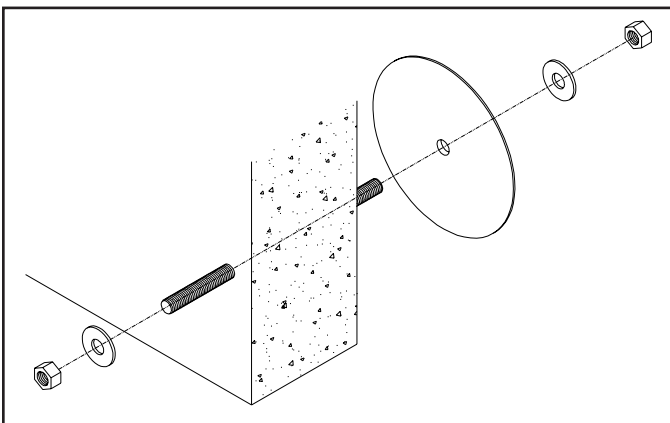
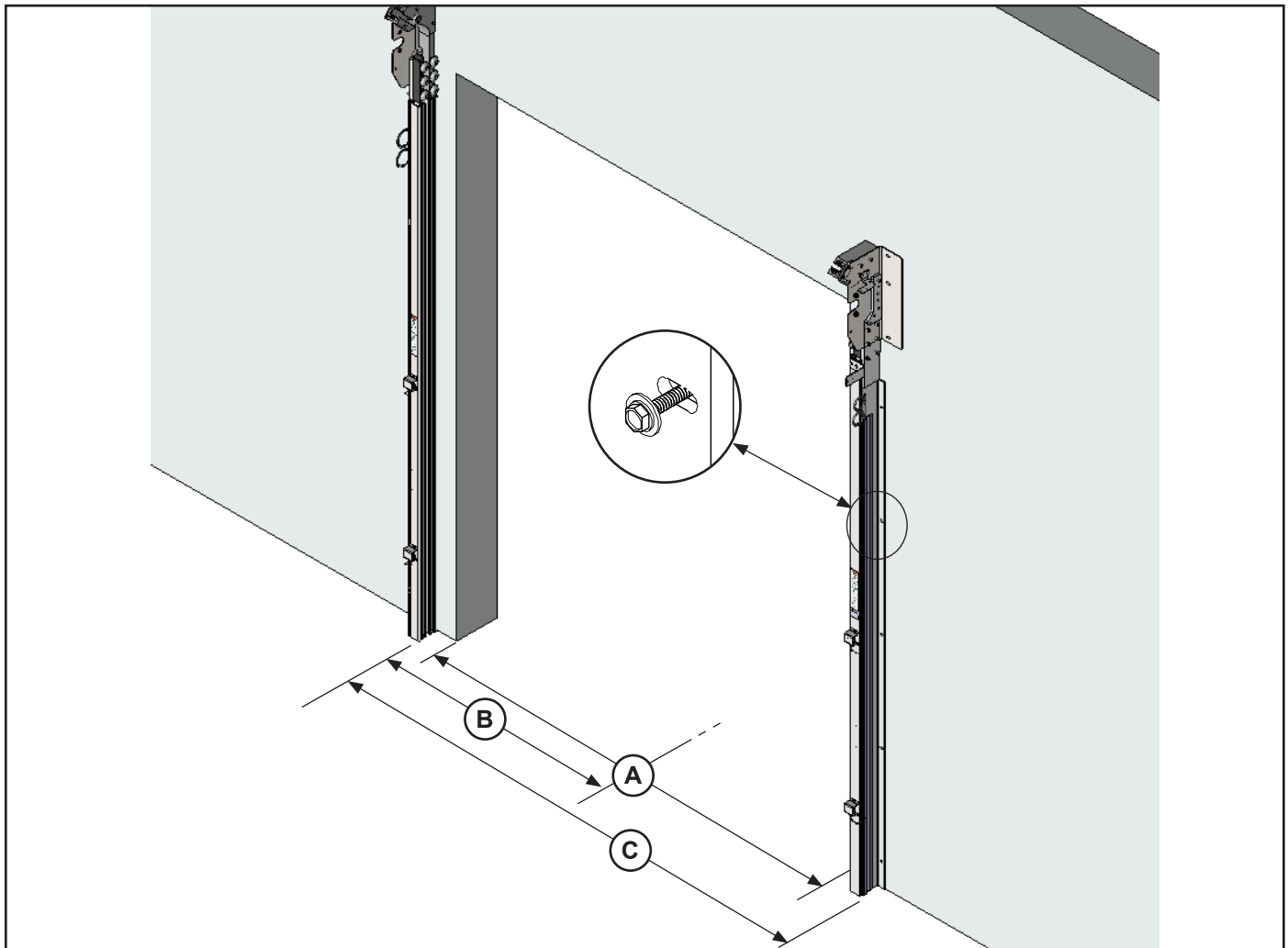

Figure 2-6

12. If backer plates are being used, they must be clean and either be painted or a non-ferrous material.



A - Ordered Door Width

B - 1/2 O.D.W. + 4 1/2" [114 mm] (+ 1/16" [1.5 mm], -0")

C - Ordered Door Width + 9" [229 mm] (+ 1/8" [3 mm], -0")

Figure 2-7

13. Using the pre-drilled slots in the track as a guide, mark and drill a hole and place a fastener in the center of the slot at the top, (middle), bottom and tighten. Slot location will vary based on ordered height.

If the hole goes completely through the wall, use thru-bolts and backing plates to secure the track to the wall, "Figure 2-6".

Sleeves may be required if wall collapses when tightening thru-bolt. It is the responsibility of the installer to ensure proper lower track spacing and adequate method of fastening to the wall.

14. After the door is installed and operational make sure the curtain is not too tight or loose. Place fasteners in the remaining holes. It is imperative that all the holes are utilized to prevent lower track movement.

15. For optional weld plates, refer to [page 62](#).

UPPER TRACK WRAP BACK

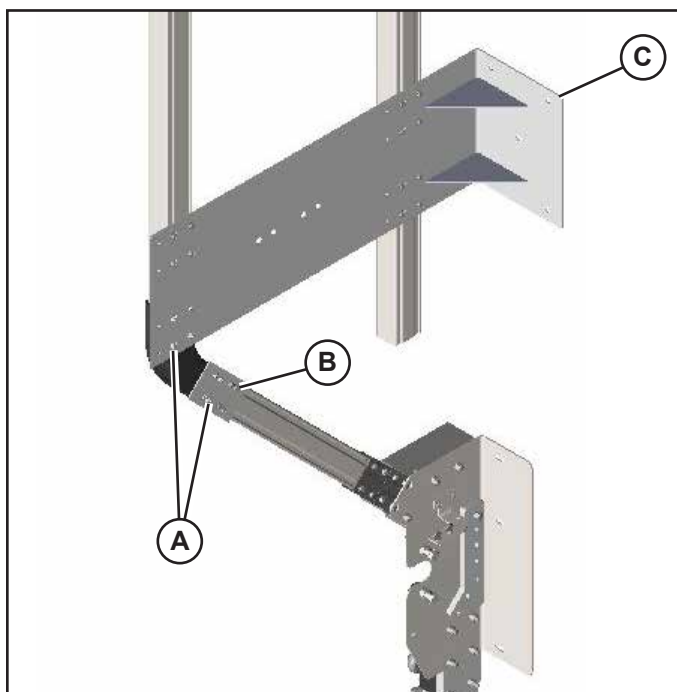

Figure 2-8

1. Pilot holes (.201Ø x 1 1/4" [5x32 mm] deep) (A) MUST be pre-drilled into upper track radius. Make sure drill is perpendicular and level. (4) lag screws per location. DO NOT drill into curtain groove.
2. Use Self/Tap Drill screws (B) in aluminum track, (4) places each location.
3. Fasten upper wall mount bracket (C) to track and wall. Minimum 6"x 6" [152 x 152 mm] backer plate required on hollow / insulated walls. Can be mounted leg in or leg out.

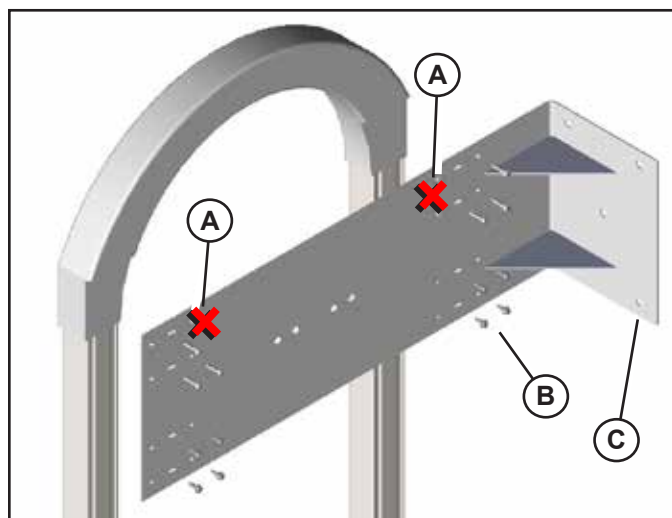

Figure 2-9

4. (B) Use Self/Tap Drill screws in aluminum track, (4) places each location.
5. Fasten upper wall mount bracket (C) to track and wall. Minimum 6"x 6" [152 x 152 mm] backer plate required on hollow / insulated walls. Can be mounted leg in or leg out.
6. Pilot holes (.201Ø x 1 1/4" [5x32 mm] deep) MUST be pre-drilled into upper track radius. Make sure drill is perpendicular and level. (3) lag screws per location; do not use upper inside holes (A). DO NOT drill into curtain groove.



Figure 2-10

7. Attach spreader bar (A) between wrap back brackets.

UPPER TRACK VERTICAL LIFT

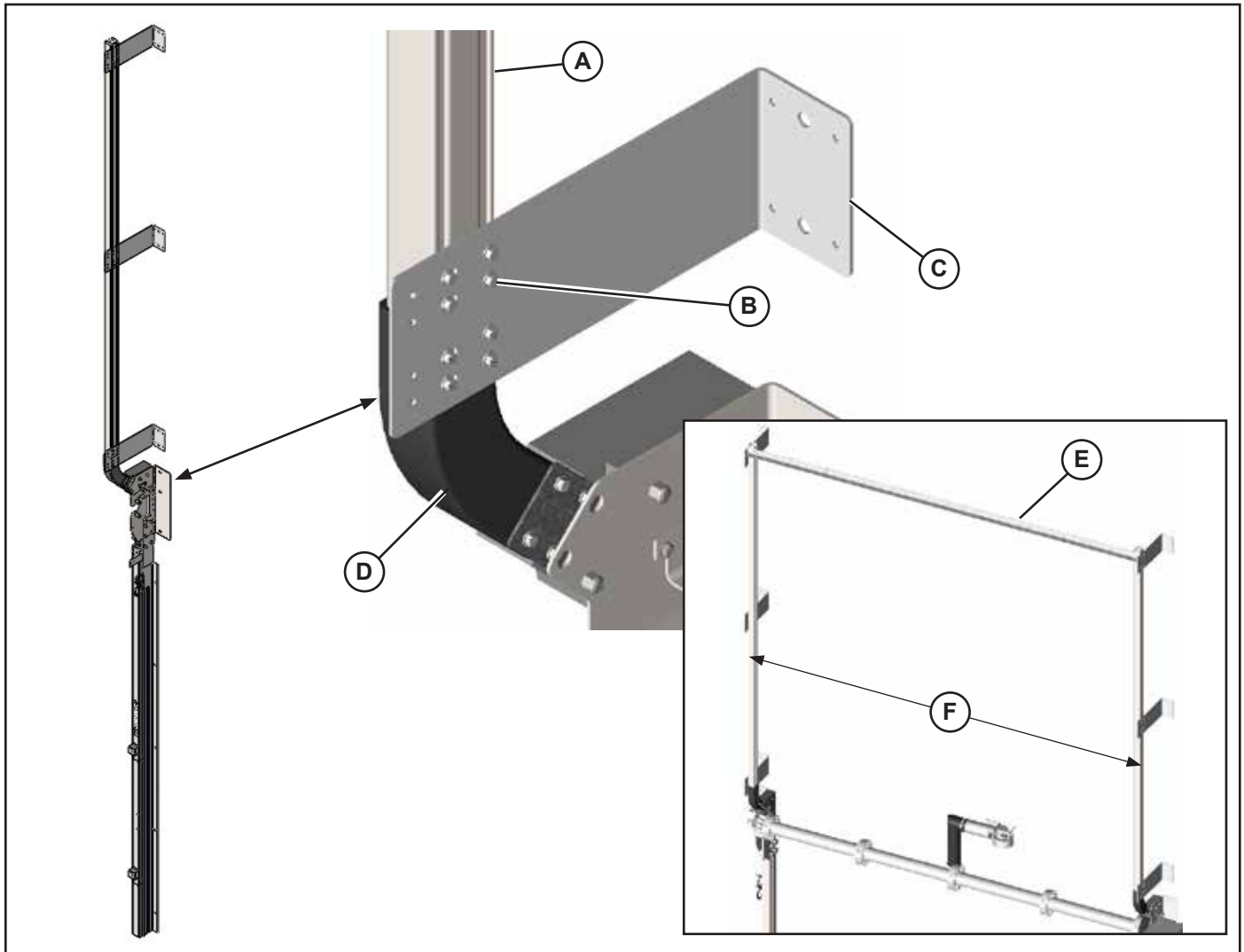

Figure 2-11

1. The proper radius (D) is already assembled to the lower track.
2. Pilot holes (.201Ø x 1 1/4" [5x32 mm] deep) MUST be pre-drilled into lower track radius (B). Make sure drill is perpendicular and level. DO NOT drill into curtain groove
3. Place mounting bracket (C) in position and mark holes to be drilled in wall.
4. Locate the 2 pieces of upper track (A) and the supplied wall mount brackets. Slide end of upper track into the lower track radius, level, plumb and fasten to wall mount bracket using self/tap drill screws.
5. From outside to outside of tracks measure (F): O.D.W. +14" [357 mm] (+1/8" [3 mm]/-0).
6. Attach punched angle spreader bar (E) between upper track.

! CAUTION

Make sure to place screws so they go into the outer cavities of the upper track and not into the curtain groove. The drill MUST be held perpendicular and level to ensure screw does not go into groove.

UPPER TRACK HIGH LIFT

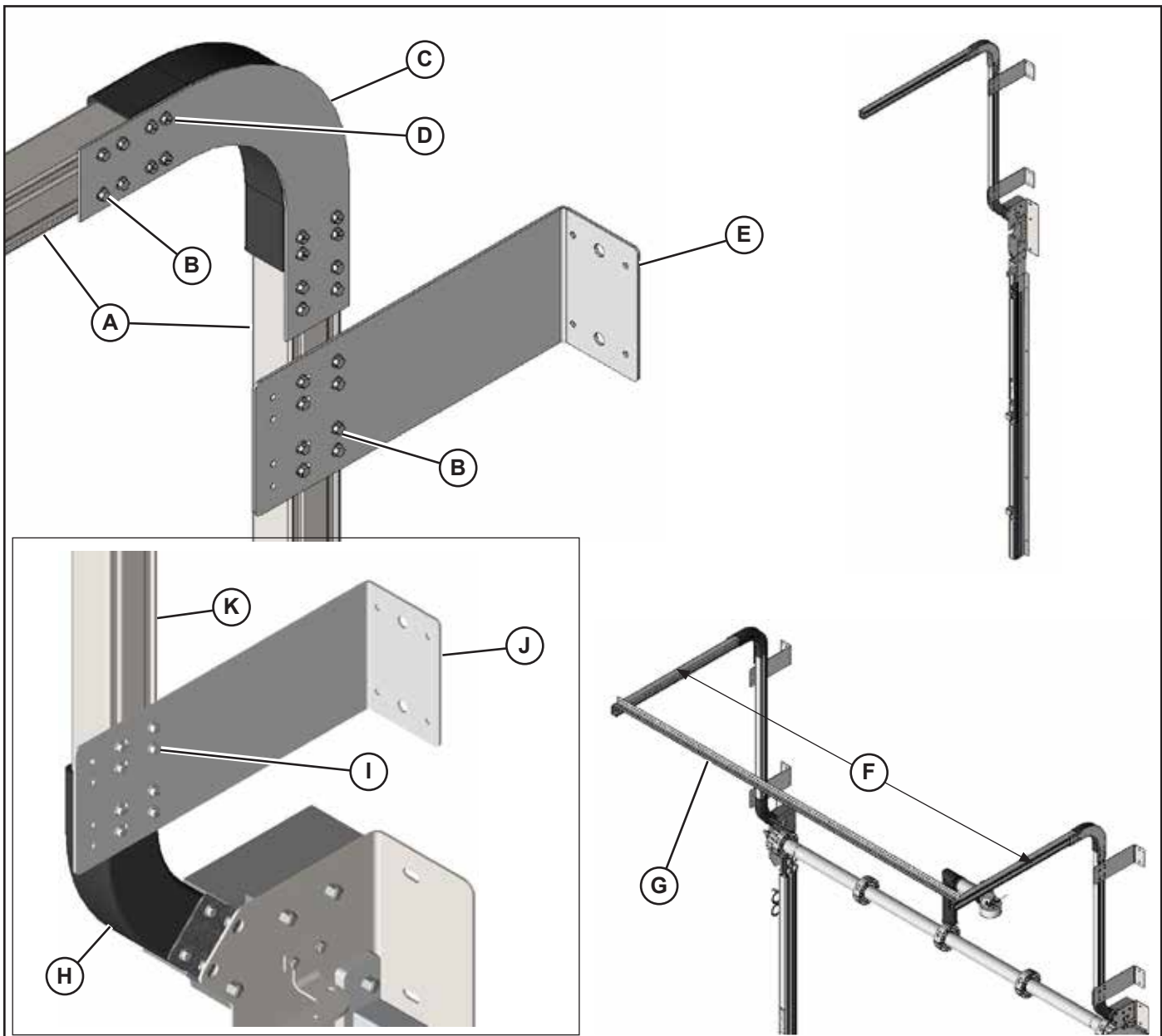

Figure 2-12

1. The proper radius (H) is already assembled to the lower track.
2. Pilot holes (.201Ø x 1 1/4" [5x32 mm] deep) MUST be pre-drilled into lower track radius (I). Make sure drill is perpendicular and level. DO NOT drill into curtain groove
3. Place mounting bracket (J) in position and mark holes to be drilled in wall.
4. Locate the 2 pieces of upper track (K) and the supplied wall mount brackets. Slide end of upper track into the lower track radius, level, plumb and fasten to wall mount bracket using self/tap drill screws.
5. Use Self/Tap Drill screws (B) in horizontal and vertical track.

NOTE: In the illustration above, (A) is High Lift Track.

6. Fasten upper wall mount bracket (E) to track and wall, below radius and splice bracket. Minimum 6"x 6" [152 x 152 mm] backer plate required on hollow / insulated walls.
7. Use track splice bracket (C) to join lower and upper track. Drill .201Ø [5 mm] pilot hole 1 1/4" [32 mm] deep for lag screws.
8. Use lag screws (D) in radius bracket.
9. From outside to outside of tracks (F) measure O.D.W. +14" [357 mm] (+1/8" [3 mm]/-0).
10. Attach punched angle spreader bar (G) between upper track.

 **CAUTION**

Make sure to place screws so they go into the outer cavities of the upper track and not into the curtain groove. The drill MUST be held perpendicular and level to ensure screw does not go into groove.

UPPER TRACK STANDARD LIFT

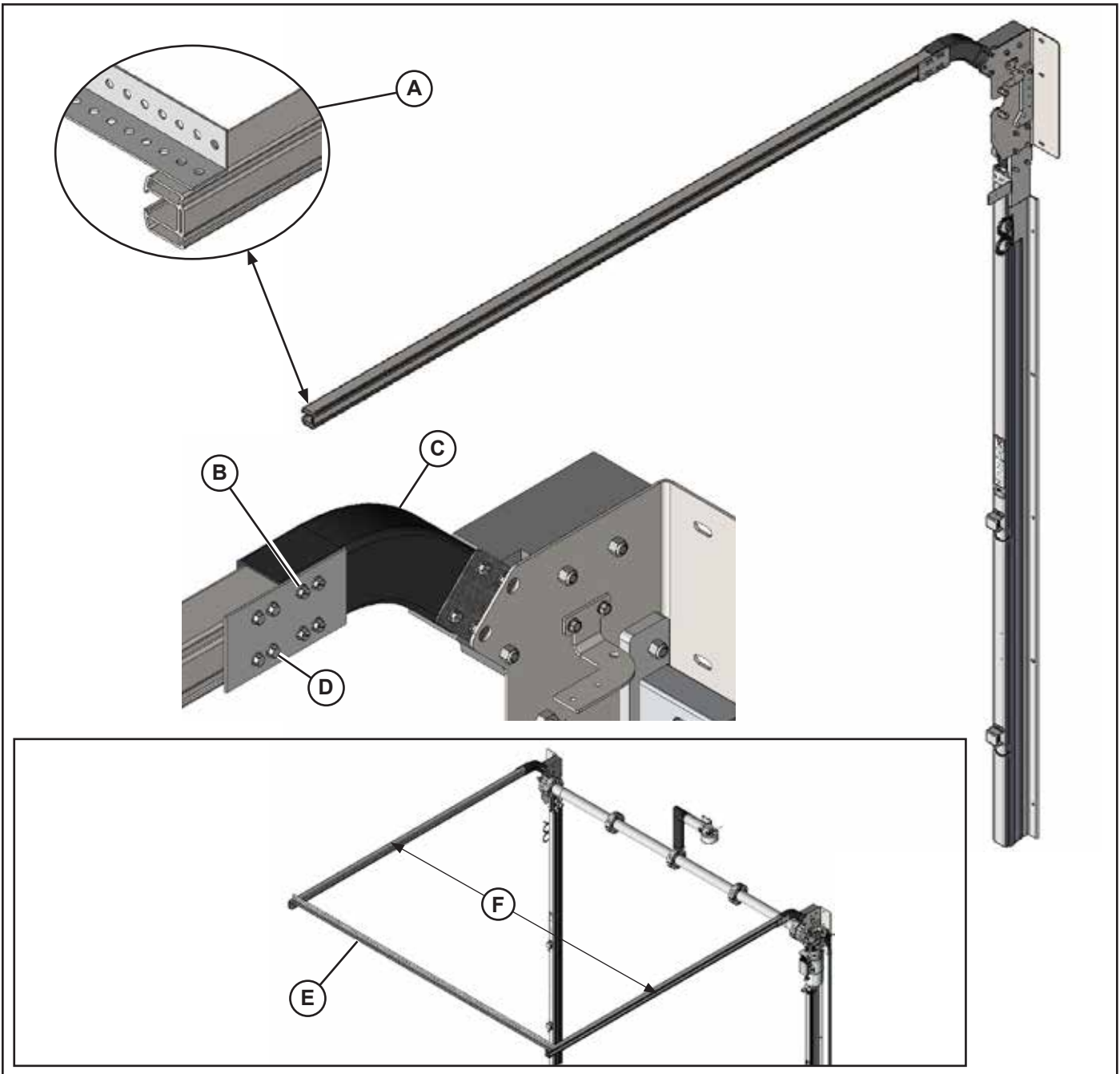

Figure 2-13

1. The proper radius (C) is already assembled to the lower track.
2. DO NOT use self tap screws at location (B), but self tap screws are acceptable for use at location (D).

Locate splice bracket and fasten between the upper and lower track. Pilot holes (.201Ø x 1 1/4" [5x32 mm] deep) MUST be pre-drilled into lower track radius. Make sure drill is perpendicular and level. DO NOT drill into curtain groove.

3. At the end of the track, place punched angle (A) and drive a self-tap screw into the curtain groove to prevent curtain top roller from coming out of track.
4. From outside to outside of tracks (F) measure O.D.W. + 14" [357 mm] (+ 1/8"[3 mm]/-0).
5. Attach punched angle spreader bar (E) between upper track.

 **CAUTION**

Make sure to place screws so they go into the outer cavities of the upper track and not into the curtain groove. The drill MUST be held perpendicular and level to ensure screw does not go into groove.

UPPER TRACK 45° TILT LIFT

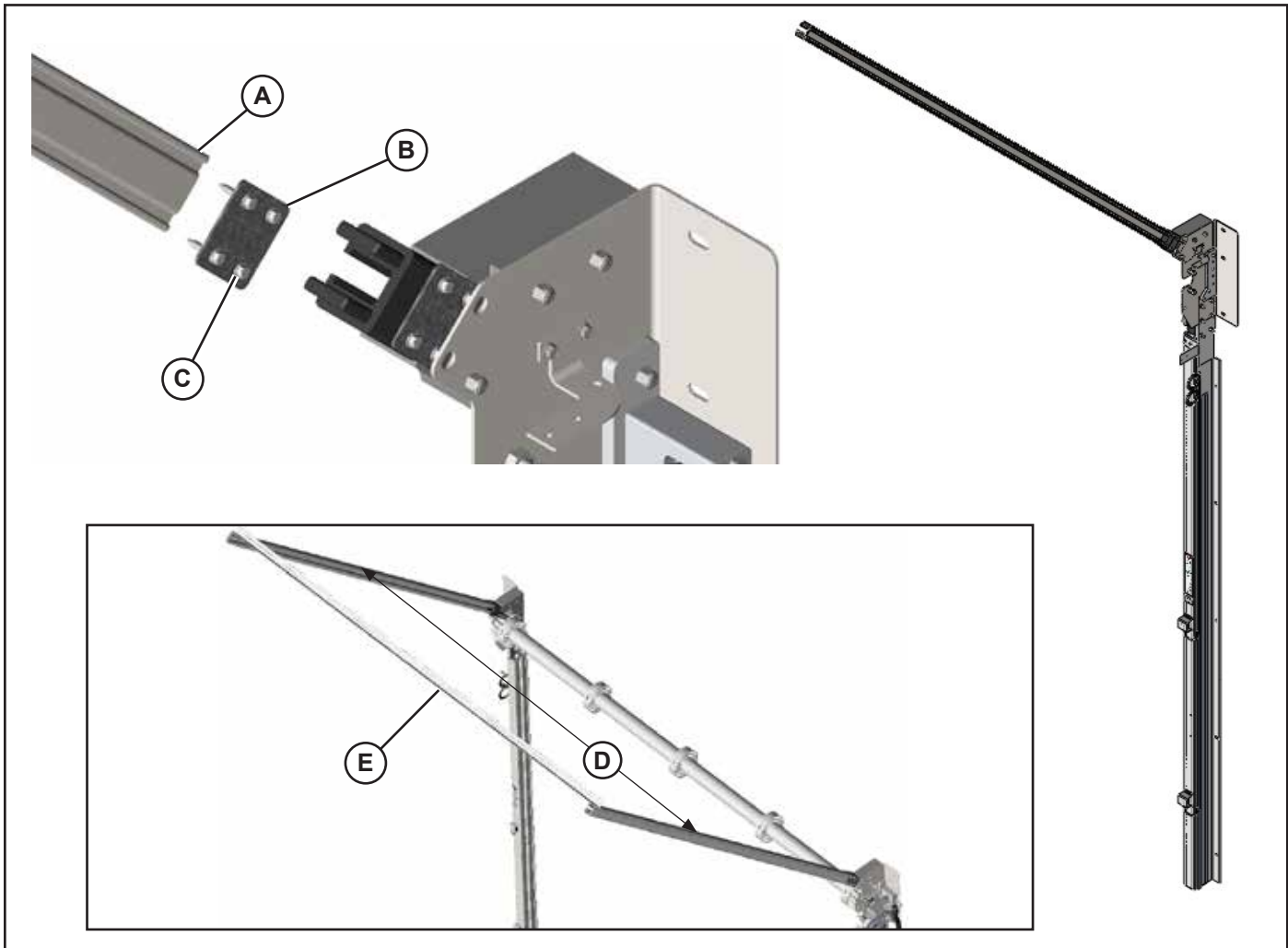

Figure 2-14

1. Use track splice bracket (B) to join lower and upper track (A). Drill .201Ø [5 mm] pilot hole 1 1/4" [32 mm] deep for self drill/tap screws (C).
2. From outside to outside of tracks (D), measure O.D.W. + 14" [357 mm] (+ 1/8" [3 mm]/-0).
3. Attach punched angle spreader bar (E) between upper track.

! CAUTION

Make sure to place screws so they go into the outer cavities of the upper track and not into the curtain groove. The drill MUST be held perpendicular and level to ensure screw does not go into groove.

CHAPTER 3

DRIVE TUBE INSTALLATION

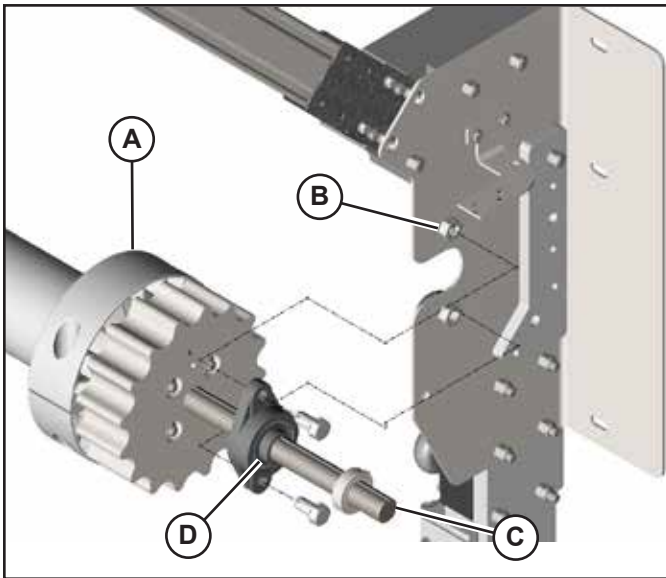

Figure 3-1

1. Remove the (4) 1/2" [13 mm] bolts and lock washers (B) from the bearing mount weld nuts on drive and non-drive sides.
2. Drive end of shaft (C) is longer than the non-drive side. If chain hoist option is included, the longer shaft is still on the drive side.
3. Loosen set screws on bearings (D) prior to lifting drive tube.
4. Lift drive tube (A) in place and fasten the drive and non-drive bearings onto the mounting plate with the (4) 1/2" [13 mm] bolts and lock washers removed earlier.

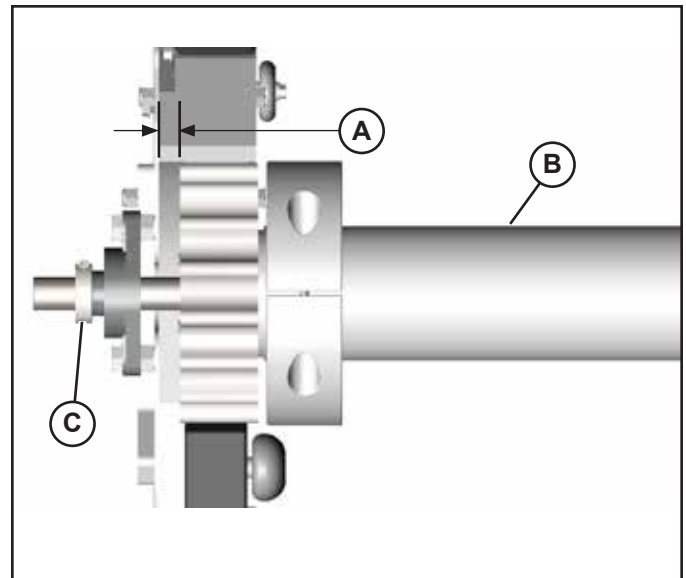
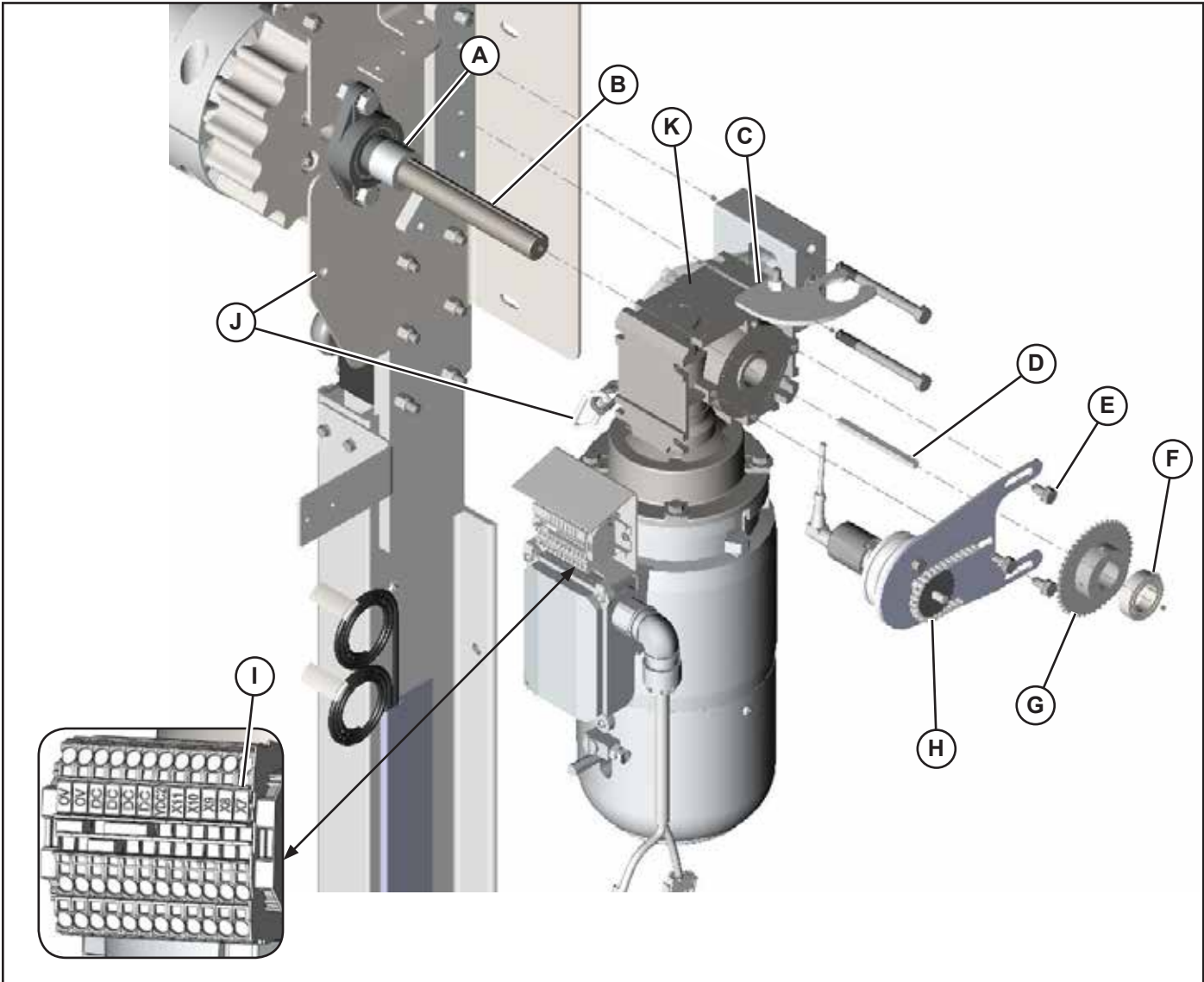

Figure 3-2

5. ****Critical Centering Dimension** (A)**
Loosen lock collar set screws on bearings. Measure from inside mounting plate to face of drive gear, approximately 5/8" [16 mm]. Tighten bearing set screws when this dimension is equal on both sides.
6. Slide lock collar (C) next to bearing and tighten lock collar set screws.
7. Place a level on the drive tube (B) to verify tube is level to within 1/8" [3 mm]. If not, shim lower track as needed.

MOTOR / ENCODER INSTALLATION



A - Spacer	G - Encoder Drive Sprocket
B - Drive Shaft	H - Encoder Chain
C - Conduit Bracket	I - X7 Terminal
D - Key	J - Chain Connector
E - Top Bolt	K - Gearbox # 50
F - Lock Collar	L - Gearbox # 63

Figure 3-3

8. Remove lock collar (F) from drive shaft (B). Slide gearbox housing onto shaft until it is against the spacer.
9. Rotate the drive tube until the key-way slots are aligned and install key (D). Re-install lock collar (115 in/lbs) [13 N-m].
10. Finger tighten top bolt (E) on encoder mounting plate to gearbox.
11. Slide encoder drive sprocket (G) onto the drive shaft.
12. Install encoder chain (H) around sprockets.
13. Finger tighten remaining two mounting plate bolts.
14. Measure from each sprocket to plate to align. Tension chain and tighten mounting plate bolts.
15. Tighten set screw on drive sprocket using a 3/32" allen wrench. (Do NOT overtighten—5 in/lbs [0.56 N-m]) Sprocket does NOT require a key.

NOTE: If side clearance is not available (minimum 18" [457 mm]) to install gearbox after drive tube is installed, place gearbox onto shaft prior to installing drive tube. A lifting device will be necessary for this procedure.

NOTE: X7 terminal (I) can be used for activation devices.

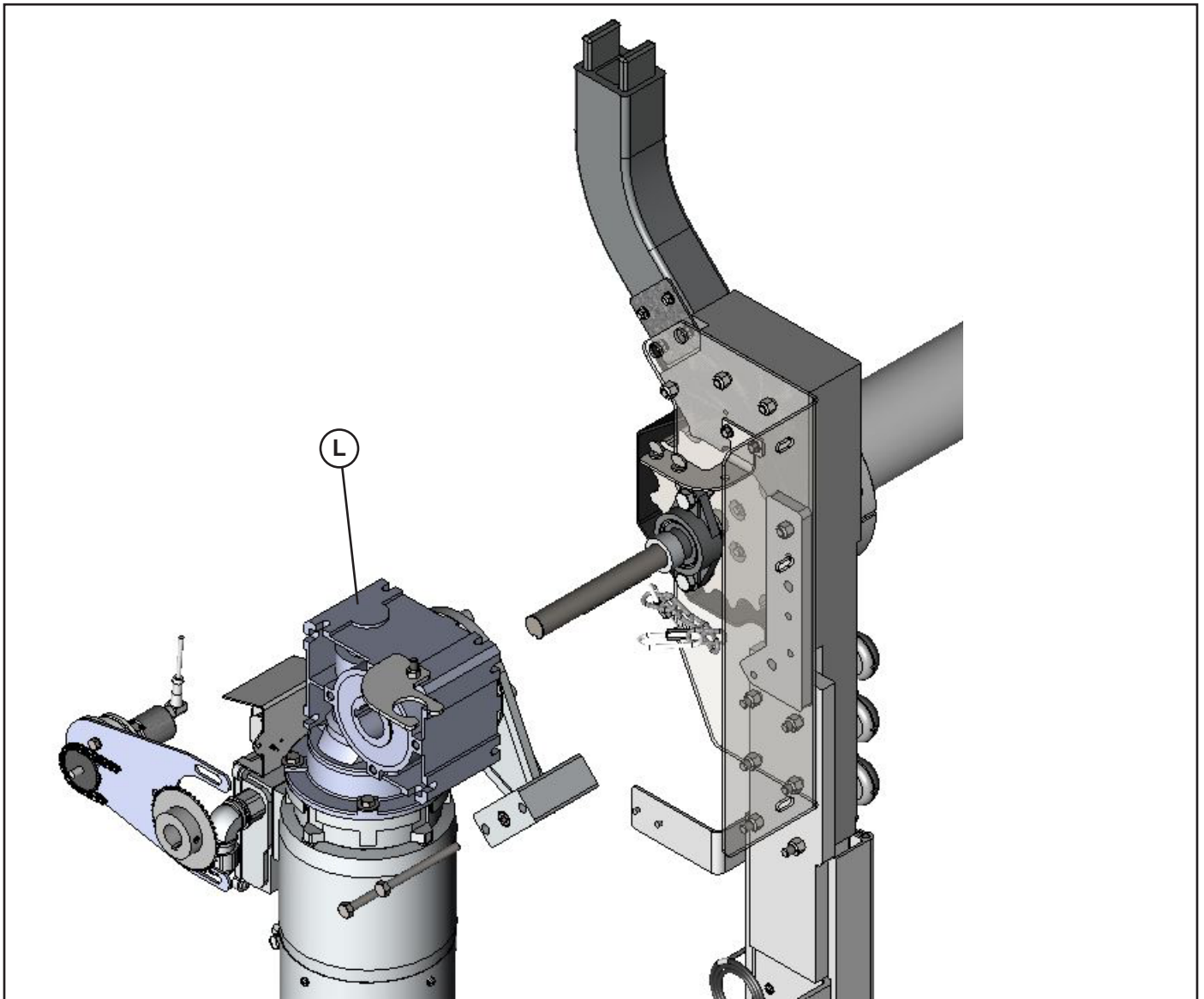

CURTAIN INSTALLATION

MOTOR PHASING

NOTE: If electrical is available, bypass **Figures 3-4 through 3-6** and proceed to **“ELECTRICAL INSTALLATION”** on page 37, and then return here. If electrical is not complete, proceed to install curtain per **Figures 3-4 through 3-6**.

1. With electrical complete, turn disconnect to “ON”.
2. When pressing the “OPEN” button, the drive tube should rotate counter-clockwise on right hand drive door and clockwise on left hand drive door. (The back of the tube should be turning toward the ceiling.)
3. If the drive tube rotates in the opposite direction, switch wires in motor terminals U & V.

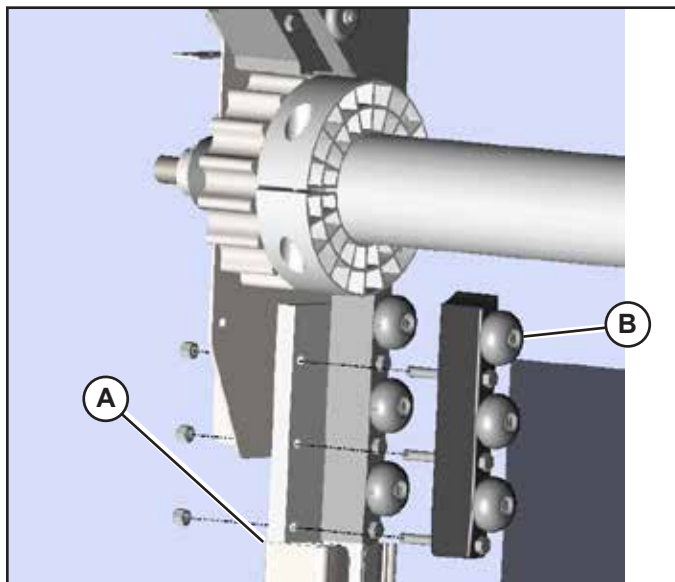

A - Lower Track
B - Refeed Rollers

Figure 3-4: Refeed Rollers

1. Remove the three 3/8” [10 mm] hex head bolts holding the front refeed rollers (B) in place (both sides).

NOTICE

Top curtain roller bracket should be positioned such that the roller shaft is toward the curtain and away from the wall.

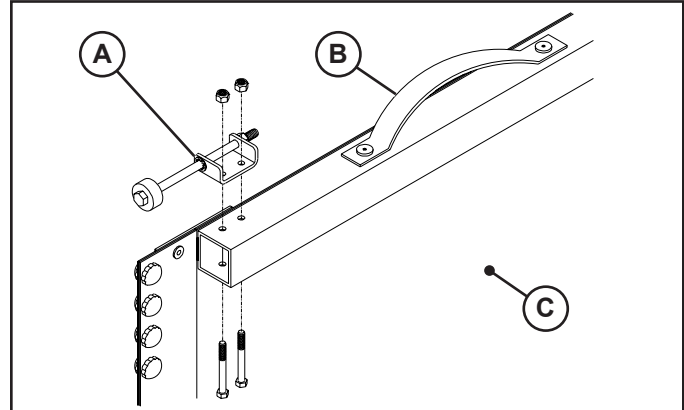

A - Curtain Roller
B - Curtain Lifting Handle
C - Back (Wall Side)

Figure 3-5: Curtain Top Roller

2. Remove both top curtain rollers to feed through drive gears (two-7/16” [11 mm] bolts).

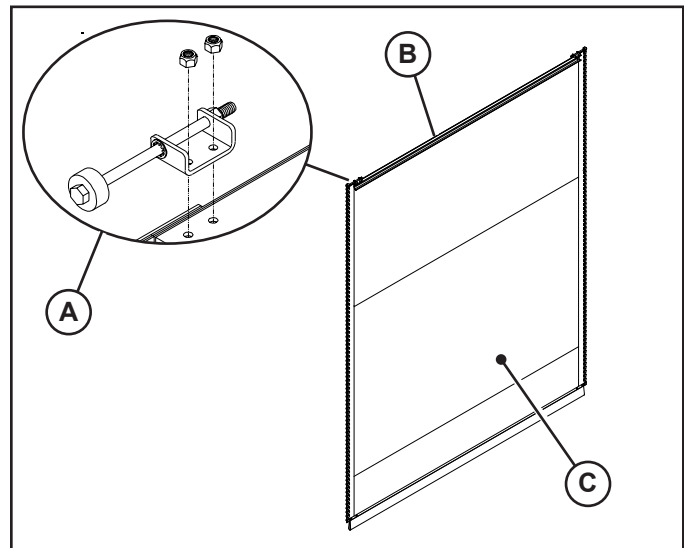

A - Curtain Roller
B - Curtain
C - Back (Wall Side)

Figure 3-6: Curtain Installation

3. Remove both top curtain rollers (A) to feed through drive gears (two-7/16" [11 mm] bolts).
4. Disengage brake by pulling the handle on the brake and locking in place, **Figure 3-6**.
5. Place curtain in front of the opening so that the top edge with the metal stiffener is facing the wall.
6. Raise curtain and feed top drive sphere around the back side of the drive gear and into the radius and/or upper track approximately 6" [152 mm] by rotating drive tube to drive curtain through the drive gears. Release brake handle to hold curtain.
7. Fasten curtain top roller bracket back onto the curtain brace. Refer to **Figure 3-4**.
8. Once top rollers are securely fastened, disengage brake and continue to route curtain through opening in lower track. Refer to **Figure 3-4**.
9. Refer to **Figure 3-4**. After curtain is fully into the track, re-install front refeed rollers back onto the lower track. DO NOT overtighten bolts. Make sure refeed rollers are flush with lower track (B). when installing.

NOTICE

Curtain needs to be stopped at or before it reaches the top of the jamb.

WARNING

The curtain may close very quickly if the brake is fully released. Releasing the brake partially will allow the door to close smoothly. Failure to restrict the curtain speed, can result in damage to product or injury to personnel.

CHAPTER 4**ELECTRICAL INSTALLATION**

GENERAL ELECTRICAL INSTALLATION NOTES

1. It is the responsibility of the end user to provide electrical service up to the control box with proper branch service protection and an approved means of disconnect. The disconnect on the front of the control box is not a true disconnect.
2. 20 or 30 ampere service may be required for cable runs longer than 300' [91,440 mm].
3. Local electrical codes may require the use of rigid conduit rather than flexible conduit. If so, remove conduit connector, control cables from the flexible conduit and install the rigid conduit in its place and rewire.
4. Mount control box adjacent to the door at approximately 54" [1372 mm] above the floor and 14" [356 mm] from lower track.
5. If possible, mount on the warm side regardless of door mount side.
6. **All holes drilled through the control box must be through the bottom of the box. Conduit entering the sides or top of the enclosure will void the warranty.**
7. Use the proper sealed connectors to maintain the NEMA rating on the enclosure.
8. Incoming 3-phase power must connect into fuse holder terminals F1, F2, F3 and ground terminal. Terminals in the control box will not accommodate wires larger than 12 gauge wire.
9. Route all field installed wires so that separation is maintained between line voltage wires and low voltage class II wiring.
10. The control box is provided with time delay (class CC) protective fusing for the incoming power.
11. Clamp conduit to wall after complete.
12. The control box cable is pre-wired to the control box. Attach control box cable to the conduit mounting bracket on the gearbox. Connect, motor, brake cables and fasten Terminal Strip to the motor junction box. If the flexible conduit is too long, unwire control box cable wires and cut the protective outer casing the required amount. DO NOT coil or let conduit hang on the floor.
13. In freezer and cooler applications where a conduit passes from a warm to cold temperature zone, the conduit must be sealed with an approved material per 300.7(a) of the National Electric Code (NFPA 70).
14. Refer to electrical diagrams for this door for further information.

NOTE: *DO NOT SPLICE CONTROL WIRING*

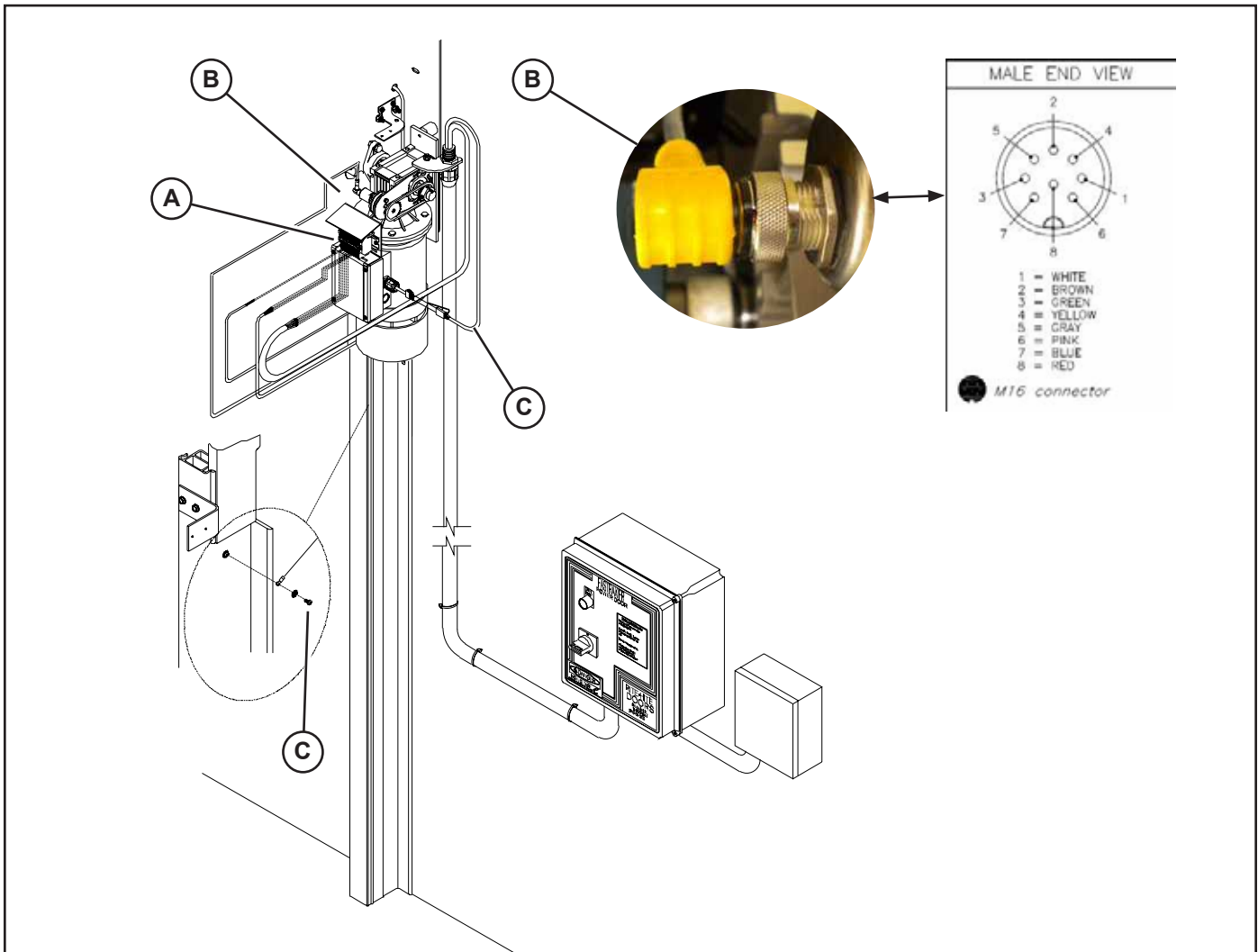

Figure 4-1

1. Connect encoder cable (B) to encoder. Make sure to line up pins properly. Make sure connector is tight, but do not over-tighten, as pins will twist. Once tight, the connector should not be able to move back and forth.
2. Control box cable is pre-wired to the Terminal Strip (A). Use electrical drawing on [page 75](#) for details.

NOTE: *Wire (C) MUST be properly grounded.*

FASTRAX® FR LD

A	Serial Number Label
B	i-COMM
C	Do Not Drill Label—Remove After Installation Is Complete
D	Red Bold Solid Line Indicates Unsafe Area for Drilling Holes
E	Incoming Power Terminals F1, F2, F3 for 230/460/400/575V 3Ø Configuration
F	Green Bold Dashed Line Indicates Safe Area for Drilling Holes
G	Incoming Power FasTrax FR LD
H	Incoming Power Terminals F1, F2 for 220V 1Ø
I	Red Disconnect Switch
J	Green Open/Reset Button

The i-COMM (B) is used to control all functions of the door. Note label inside control box that is a ready reference to the i-COMM inputs and outputs, [page 41](#).

The red disconnect switch (I) stops door operation. The control is rotated to the “ON” position for normal door operation. To stop door operation, rotate the control to the “OFF” position. Whenever the door operation is stopped by using the disconnect switch, you must do the following to resume operation:

1. Rotate the red disconnect switch to the “ON” position.
2. Press the “OPEN/RESET” button to reset and operate the door.

The green button (J) opens and resets the door after a fault. To “OPEN”, press and release the button. The i-COMM will automatically close the door after the preset time has expired.

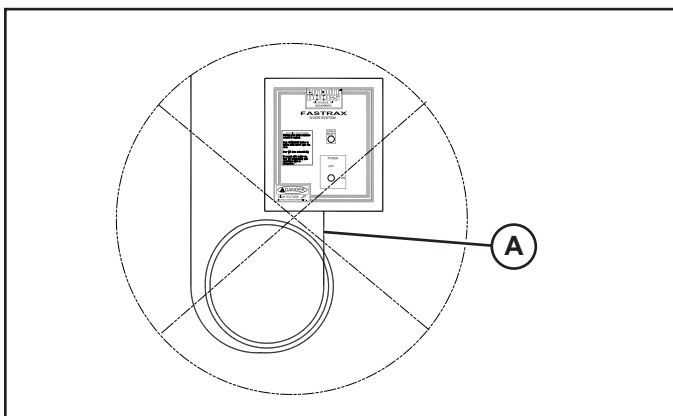

Figure 4–3

Cut cable (A) to proper length. Do not coil.

I-COMM II LOGIC CHART



FasTrax™ Encoder i-COMM II Quick Reference

INPUT TABLE	
Input	Function
X0	Open PB
X1	Stop PB
X2,X3,X6,X7	Activation Command
X4	Close PB
X5	Toggle Command
X8*,X9*	IZone Sensors (R & L)
X10*	18" Photoeye Input
X11*	54" Photoeye Input
X12	Open/Reset PB
X13	Induction Loop Input
X14*	Fault Input
X15*	Input Power

OUTPUT TABLE	
Relay Output	Function
YK0	Interlock Out
YK1	Programmable
YK2	Programmable
DC Output	Function
YDC0	On when door Open
YDC1	Photoeye Test
*YDC2	Photoeye Test
*YDC3	Open/Reset PB Light
*YDC4	I-Zone Alarm
YDC5	Preannouncement to Close
*YDC6	NPO Contactor
*YDC7	Disabled

* Not shown in I/O menu and not programmable

Encoder Adjustment Descriptions

(Refer to i-COMM and Owners Manuals for additional detail)

Open Distance	Use this option to set the overall opening distance of the door (in feet). This measurement is used for initial position setup only. For small adjustments of the open and close position, use "Close Position Adjust" or "Open Position Adjust"
Set Close Position	Use this option for initial position setup. Manually place door in the close position and select this option. Alternatively "Set Open Pos." can be used if it is more convenient to place the door in the open position.
Set Open Position	Use this option for initial position setup. Manually place door in the open position and select this option. Alternatively "Set Close Pos." can be used if it is more convenient to place the door in the closed position.
Close Position Adjust	Use this option to make small adjustment to the closed position. The number displayed is the relative displacement of the closed position.
Open Position Adjust	Use this option to make small adjustment to the open position. The number displayed is the measurement between the open and closed position.
Motor Drive Side	Use this option to change the encoder rotation direction. For a motor mounted on the right side of the drive tube, select "Right Drive". For a motor mounted on the left side of the drive tube, select "Left Drive".

Timer Adjustment

1. Press [ENTER]. Controller will stop and fault door.
 2. Press [UP] or [DOWN] until the timer folder is displayed.
 3. Press [ENTER], to enter the timer folder.
 4. Using [UP] & [DOWN] keys select desired timer.
 5. Press [ENTER] to view the current timer value.
 6. Use [UP] or [DOWN] keys set the desired value.
 7. Press [ENTER] to save the value and return to the timer folder.
 8. Press [BACK] until "Door Faulted" is displayed.
 9. Reset Door.
- Preannouncement Timer is the amount of time the Preannouncement to close output will be on before door closes.
 Close Timer is the amount of time the door will remain open before the preannouncement to close timer activates
 Autocycle Time is the amount of time between each automatic cycle of the door (disabled by default).

53850610-1

I-COMM II LAYOUT

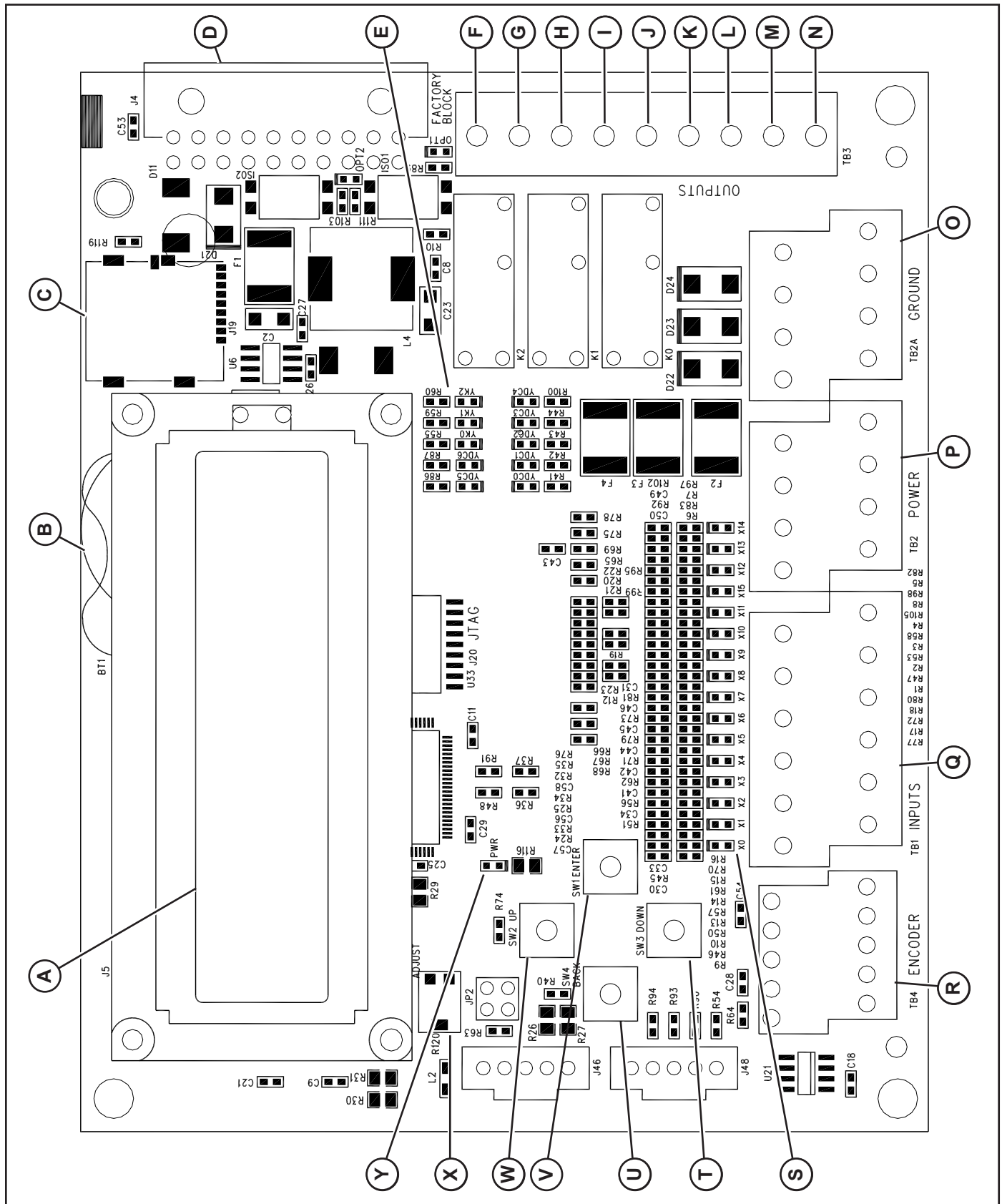

I-COMM II LAYOUT

A	Display
B	Battery—CR2032 3V
C	SD Card
D	J4 Connector
E	Output LED's K0—K2 Y0—Y5
F	YK2N
G	YK2
H	YK1N
I	YK1
J	YK0N
K	YK0
L	YDC2
M	YDC1
N	YDC0
O	OV Terminals
P	DC Terminals
Q	Input Terminals
R	Encoder Terminals
S	Input LEDs X0—X15
T	Down Button
U	Back Button
V	Enter Button
W	Up Button
X	Contrast
Y	Power LED

I-COMM ENCODER SETUP

MUST COMPLETE BEFORE OPERATING DOOR. Operation of the door is not possible when using the menu system.

ENCODER SETUP INSTRUCTIONS

1. Verify wiring to encoder is properly terminated.
2. Place curtain in the closed (or open) position. If open, curtain should be 1'-2' [305 mm–610 mm] below the lintel.
3. Power up the door and press enter button on the i-comm. The display should read **"MAIN MENU - ENCODER FOLDER"**.
4. Press enter. The display should read **"Open Distance"**.
5. Press enter to view parameter value (measured in feet). The display should show the O.D.H. - (two) 2'. Change the value using the up or down buttons. Round down if required; press enter.
6. Press up button. The display should read **"Motor Drive Side"**. Press enter and select **"Right Drive"** or **"Left Drive"**. Press enter.
7. Press up button. The display should read **"Set Close Pos."** (use if curtain is closed) or go to **"Set Open Pos."** (use if curtain is open) and press enter button. The display should read **"Set Close (or Open) Pos."** and toggle between **RESET ALL LIMITS** and **Push Up to Start"**. Press Up button.
8. Press the green flashing Open/Reset button on the front of the control box. Door should run open, time out and close. Proceed to "Open and Close Position Adjustment".

OPEN AND CLOSE POSITION ADJUSTMENT

To adjust the OPEN position:

1. Using up button, scroll to “**Open Pos. Adjust**”.
2. Press enter button to view parameter value. This parameter will show a coded value on the left and the opening height in inches on the right. This value will always be less than the door opening height.

Change the value using the up and down buttons.

To bring the open position down (closer to the floor) adjust this value to be less than the current value. To open the door more relative to the floor, adjust this parameter in a positive direction. (i.e., to open the door 4” [102 mm] more, and the current value is 72.0” [1829 mm], change the value for “**Open Pos. Adjust**” to 76.0” [1930 mm]). Changing this value will not affect the close position.

To adjust the CLOSE position:

3. Using up button, scroll to “**Close Pos. Adjust**”.
4. Press enter button to view parameter value. This parameter will show a coded value on the left and relative change in inches on the right. When entering this parameter the value will always start at 0.0”.

Change values using the up or down buttons.

To bring the curtain closer to the floor, adjust this value so that it is less than zero. (i.e. To close the door 4” [102 mm] more, the value for “**Close Pos. Adjust**” will be -4.0” [-102 mm]) Moving this parameter in the positive direction raises the curtain relative to the floor. Changing this value will not affect the open position.

NOTE: *If you leave this parameter and return*

to it, its value will again be zero. Any changes made before leaving the parameter will still be effective. For example: If you lowered the door 4.0” [102 mm], leave the parameter and return, the parameter will display 0.0”. Even though the display shows 0.0”, the -4.0” [-102 mm] change has been recorded.

TIP: At any point in the menu mode, press the back button until screen states “Door Faulted - Service Required”. This will cause the controller to automatically accept all the changes made and exit the system.

5. Changes are not saved until the menu mode is exited. Turning power off while in the menu mode will cancel all changes.
6. Test operation of door and continue adjustment.
7. Press green Open/Reset button.
 - The door should begin to open. Be ready to shut down the door if it begins to move in the wrong direction. If motor phase is changed, start over at step #2.
 - If rotation is correct, proceed to the instructions for adjusting the “Open and Close positions”.
8. Press the back (left button) to exit system.

I-COMM ENCODER DISPLAY SETUP DESCRIPTIONS

Option	Description
Open Distance	Use this option to set the overall opening distance of the door (in feet). For example, for an 8' tall FasTrax, this option should be set to 7' [2134 mm]. This measurement is used for initial position setup only. For small adjustments of the open and close position, use "Close Position Adjust" or "Open Position Adjust."
Set Close Pos	Use this option for initial position setup. Manually place door in the close position and select this option. Alternatively, "Set Open Pos." can be used if it is more convenient to place the door in the open position. NOTE: This option approximately sets the open and close positions. For additional adjustment of the open and close position, use "Close Position Adjust" or "Open Position Adjust."
Set Open Pos	Use this option for initial position setup. Manually place door in the open position and select this option. Alternatively, "Set Close Pos." can be used if it is more convenient to place the door in the closed position. NOTE: This option approximately sets the open and close positions. For additional adjustment of the open and close position, use "Close Position Adjust" or "Open Position Adjust."
Open Pos Adjust	Use this option to make small adjustments to the open position. The number displayed is the measurement between the open and closed position. For example, if this option was set to 100" [2540 mm], the door would open 100" [2540 mm] from the closed position. It is recommended to adjust the closed position of the door first before adjusting the open position.
Close Pos Adjust	Use this option to make small adjustments to the closed position. The number displayed is the relative displacement of the closed position. For example, if this option was set to -1.0" [-25 mm], the door would close approximately 1.0" [25 mm] more. If this option was set to 2.0" [51 mm], the door would close 2.0" [51 mm] less.
Apr Open Pos	Use this option to adjust the approach open position. This option is a measurement in inches from the open position. For example, if this option was set to 24.0" [610 mm], the door would slow down 24.0" [610 mm] from the open position.
Encoder Start-up	The controller is waiting for valid data from the encoder. If the controller does not receive a response at start-up, this will remain on the screen indefinitely. If this does not clear with 5 seconds, please check all encoder wiring.
Encoder Read	The controller is unable to read valid data from the encoder. Check all wiring and M12 cable connections. Ensure that the shield on the encoder cable is connected to ground, and that the control box is grounded. The error requires the power to be cycled to reset.
Encoder Velocity	The controller has received a signal from the encoder that the door is moving faster than allowed. This can occur if the encoder is not properly attached to the shaft (check set screws on encoder collar and sprockets), bad electrical connection to the i-COMM, or improper grounding. The error requires the power to be cycled to reset.
Open time limit	Door tried to run, but did not reach the open or close position within 8 seconds.
Photoeye failure	Non-Drive PE's must have green light on; drive PE's must have red & yellow lights on. Check for alignment & power to each.

I-COMM DISPLAY MESSAGES

LCD DISPLAY MESSAGES			
Top Display	Bottom Display	Reason / Fault Messages	Action Required
Door Faulted	Breakaway	Chain-fall chain was pulled, check switch	Reset / Jog Door
	Emergency Stop	E-Stop pushed	Push Open/Reset
	Encoder Read	i-COMM has detected a bad encoder read	Service Required
	Encoder Velocity	i-COMM has detected a velocity error	Service Required
	Jog to Close Pos	Displays when jogging close	None
	Jog to Open Pos	Displays when jogging open	None
	Limit Failure	Limit switch has failed	Service Required
	Low Voltage	Drop in voltage caused controller to restart	Push Open / Reset
	Menu Interrupt	Menu Interrupted	Push Open / Reset
	Normal Power Up	Indicates Loss of Power	Push Open / Reset
	Obstruction	Door has detected obstruction and reversed 3 times	Inspect & Reset
	Open Time Limit	Run open time limit exceeded	Service Required
	Photoeye Failure	Indicates problem with photoeye system	Jog To Close
	Program Inverter	Inverter is not programmed for proper door operation	Service Required
	Reset From Sleep	Indicates the controller was awakened from sleep mode	Service Required
	System Clock read	System clock failed	Service Required
	Unknown	Unknown fault	Service Required
	Unknown State	State unknown	Service Required
	VFD Fault Relay	Indicates problem with inverter relay (CE specifications only)	Service Required
	VFD Trip # xxx	Inverter is in fault; xxx Indicates the active inverter fault	Push Open / Reset
VFD Comm. Loss	i-Comm has lost communication with inverter	Service Required	
Watchdog Timer	Indicates the board's watchdog timer has reset	Service Required	
Door is Opening		DOOR IS OPENING	
Door Is Open Stand Clear	Activation On Closing in xx.xs I-Zone Detection Photoeye Blocked Waiting for cmd.	DOOR IS OPEN When not in pre-announce to close When in pre-announce to close Indicates activation on (overrides timer display) Displays closing time I-Zone active (overrides timer display) Photoeye is blocked (overrides timer display) Indicates door is waiting for manual close cmd.	None None Device Holding Open None Remove Detection Remove Obstruction Close Door
Stand Clear	Door Closing	DOOR IS CLOSING	None
Door Closed Door Closed	Cycles: xxxxxx Interlock Active	DOOR IS CLOSED Displays cycle count Door is interlocked and cannot be opened	None Perform Interlocking
Door Stopped	Push Open/Close	DOOR IS STOPPED	Open/Close Door

I-COMM II FOLDERS

NUMBER IS NOT SHOWN IN I-COMM MENU					
FOLDER	NUMBER	NAME	VALID VALUES	DESCRIPTION	DEFAULT
Encoder Folder	0	Open Distance	0-255	Used to Set Opening distance for door	8
	1	Motor Drive Side	Right Drive / Left Drive	Used to select motor drive side.	Right
	2	Set Close Position	Press UP to Start	Use for initial setup of close position	—
	3	Set Open Position	Press UP to Start	Use for initial setup of open position	—
	4	Close Position Adjust	+/- 100.0	Use to adjust close position relative to current close position.	0.0
	5	Open Position Adjust	0–990.00	Use to adjust door open position	—
	6	Encoder Position	0–01FFFF	Current encoder position	—
	7	Encoder Baud	433 kbps	Used to select encoder data rate	433 KBPS
	8	Approach Open Pos.	999.0	Used to select Approach Open Position	28.0
	9	Approach Close Pos.	999.0	Used to select Approach Close Position	40.0
I/O Setup Folder	10	Set Open PB Function	Auto Close Mode; Toggle & Auto Close, Reset/Jog only; Toggle Mode	Use to select the function of the Open/Reset button.	Auto Close Mode
	11	Set Loop Function	Auto Close Mode, Reverse / Hold Open	Use to select induction loop input function	Auto Close Mode
	12	I - Zone System	Enabled / Disabled	Use to Enable / Disable the I-Zone system	Disabled
	13	Output Def. YK0	0–33 (See Table)	User configurable relay	0
	14	Output Def. YK1	0–33 (See Table)	User configurable relay	20
	15	Output Def. YK2	0–33 (See Table)	User configurable relay	20
	16	Output Def. YDC0	0–33 (See Table)	User configurable DC output	3
	17	Output Def. YDC1	0–33 (See Table)	User configurable DC output	29
	18	Output Def. YDC2	0–33 (See Table)	Internal - not available DC output	29
	19	Output Def. YDC3	0–33 (See Table)	Internal - not available DC output	20
	20	Output Def. YDC4	0–33 (See Table)	Internal - not available DC output	20
	21	Output Def. YDC5	0–33 (See Table)	User configurable DC output	2
	22	Output Def. YDC6	0–33 (See Table)	Internal - not available DC output	20
	23	Output Def. YDC7	0–33 (See Table)	Internal - not available DC output	20
	24	Input Define X0	0–17 (See Table)	User configurable input	8
	25	Input Define X1	0–17 (See Table)	User configurable input	7
	26	Input Define X2	0–17 (See Table)	User configurable input	2
	27	Input Define X3	0–17 (See Table)	User configurable input	2
	28	Input Define X4	0–17 (See Table)	User configurable input	4
	29	Input Define X5	0–17 (See Table)	User configurable input	3
	30	Input Define X6	0–17 (See Table)	User configurable input	2
	31	Input Define X7	0–17 (See Table)	User configurable input	2
	32	Open Alarm Time	0–255	Open Alarm Time in minutes. Requires at least one output to be configured to function 25; menu is hidden if not.	0
	33	X10 PE Cut-Out	0–30	X10 Photoeye cut-out height	24
34	X11 PE Cut-Out	0–66	X11 Photoeye cut-out height	60	
35	I-Zone Cut-Out	0–48	I-Zone cut out height	42	
Timer Folder	36	Set Close Timer	0–255 / Toggle Mode	Close Timer in seconds. Set to Toggle Mode to disable automatic closing.	6
	37	Set Pre-announce	0–255	Pre-announce to close timer in seconds	2
	38	Auto-cycle Time	0–255 Disabled	Auto-cycle Time in minutes	Disabled

Continued on the next page

FASTRAX® FR LD

NUMBER IS NOT SHOWN IN I-COMM MENU					
FOLDER	NUMBER	NAME	VALID VALUES	DESCRIPTION	DEFAULT
General Folder	39	Clock	—	Displays current time and date. To set: press UP, scroll to year- press Enter; scroll to month - press Enter; scroll to day - press Enter; scroll to hour - press Enter; scroll to minute - press Enter.	—
	40	Language	English,Espanol,Portuguese	Set LCD display language.	English
	41	PassCode	—	Use to change access mode.	—
	42	Rev. Edge Option	Enabled / Disabled	Use to enable reversing edge.	Disabled
	43	Spec. Package	Disabled, CE, Canada Opt	Used to enable specification packages.	Disabled
	44	Remote Display	Enabled / Disabled	Used to enable remote LCD	Disabled
	45	Partial Config.	—	Consult Engineering. Special Applications only.	—
	46	Reverse Delay	XX	Reverse Delay.	0
	47	AB Inverter Delay	—	Consult Engineering. Special Applications only.	—
	48	Voltage	208/220/230/400/460/575	Voltage of Door.	460
	49	Square Feet	0–999	Square footage of door. Width x Height.	0
	50	Non-Powered Open	Enabled / Disabled	Enables non-powered open for LiteSpeed	Disabled
	51	Maintenance Months	XX	Number of months before maintenance indicator goes off. Note: Once changed, user must initiate "Reset Maintenance" Procedure.	6
	52	Maintenance Cycles	0–100000	Number of cycles before maintenance indicator goes off. Note: Once changed, user must initiate "Reset Maintenance" Procedure.	100000
53	Reset Maintenance	—	Resets Maintenance Counters and Timers. Press Up to initiate the reset.	—	
54	Reset to Default	—	Resets all settings back to factory defaults.	—	
View Folder	55	Display Cycle Count	0–99999999	Displays current Cycle Count	—
	56	Fault History	—	Displays fault log. Use Up and Down to scroll	—
	57	Display Model #	—	Displays door model number	—
	58	Display RHC #	—	Displays RHC number	—
	59	Display Serial #	—	Displays door serial number	—
	60	Firmware Revision	—	Displays current program revisions	—
Load / Save Folder	61	Copy from SD	Press UP to Start Copy	Use to upgrade i-COMM II program. Correct .BIN file must be saved to SD Card. Note: Card must be SD - 2GB or SDHC - 4,8,16 or 32 GB.	—
	62	Copy to SD Card	Press UP to Start Copy	Use to copy i-COMM II program to SD Card in .BIN format.	—
	63	Legal info to SD	Press UP to Start Copy	Use to display legal information about program. Legal.txt will be saved to SD card.	—
	64	Bootloader Upgrade	Press UP to Start Copy	Used to upgrade bootloader. CAUTION: DO NOT INTERRUPT THIS PROCESS	—
	65	Export Settings	Press UP to Start Copy	Use to save i-COMM II settings to SD Card in .BIN format.	—
	66	Import Settings	Press UP to Start Copy	Use to copy i-COMM II settings to SD Card in .BIN format.	—
Inverter Folder	67	Inverter Type	CT SK MODBUS, AB PF40 MODBUS, CT SK NO MODBUS, AP PF NO MODBUS, No Inverter	Used to set inverter type	CT SK MODBUS
	68	Program Inverter	Press UP to Start Copy	Use to program inverter.	—
	69	Open Speed	0–70 Hz	Open Speed	70.0
	70	Close Speed	0–70 Hz	Close Speed	Varies
	71	Approach Speed	0–70 Hz	Approach Open Speed	40.0
	72	Accel Time	0–10.0 s	Acceleration Rate	0.3
	73	Decel Time	0–10.0 s	Deceleration Rate	1.0
	74	Torque Reverse Level	0–100 %	Torque Reversing Level	60.0%
	75	DC Brake Time	0–10.0 s	Injection Braking Time	0.4
	76	DC Brake Level	0–100 %	DC Injection Braking Level	50.0 %

NUMBER IS NOT SHOWN IN I-COMM MENU					
FOLDER	NUMBER	NAME	VALID VALUES	DESCRIPTION	DEFAULT

I-COMM II INPUT / OUTPUT VALUES

TYPE	NUMBER	FUNCTION	DESCRIPTION	
INPUT	0	Interlock In	Interlock Input - When Input is set to this function door will not open until input is ON. Valid only for inputs X3, X4, and X5.	
	1	Stop N.C.	Stops the door when input is OFF.	
	2	Activation	Opens the door when input is ON, w/ Auto close.	
	3	Toggle	Open and Closes the door when ON. Door will not automatically close when opened by a toggle input.	
	4	Close	Closes the door when input is ON.	
	5	Sequential Activation	Activates door and blocks sequential activation output from triggering opposite door. Use only for sequential interlocks.	
	6	Reverse	Reverses the door when input is ON.	
	7	Stop N.O.	Stops the door when input is ON.	
	8	Manual Open	Opens the door when input is ON. This input will open from a stop condition, unlike activation. Do not connect motion sensors or other automatic devices to a manual open input.	
	9	Auto / Manual	When input is ON re-close timer is disabled.	
	10	Partial Open Activation	Opens the door to the partial open position when ON	
	11	Partial Open Toggle	Toggle open/close door to and from partial open position. See function #3 above.	
	12	Toggle w/ Auto Close	Open and Closes the door when ON. Door will automatically close when opened by this type of toggle input.	
	13	Hand / Auto Mode	When input is ON re-close timer is disabled and hold-to-run close is enabled.	
	14	Disabled	Input disabled.	
	15	Reverse N.C.	Reverses the door when input is OFF.	
	16	Clean	Opens door to "Cleaning" position when on.	
	17	E-Stop	Places door in fault when OFF.	
		18	Seq. Activation 2	Consult Engineering
		19	LZR in N.C.	Reverses the door when off and monitors the input for fault
	20	Pre-announcement to Open	Opens the door after the set amount of time in the Preann. to Open timer. Immediate reversal / activation if the door is not closed.	

Continued on the next page

FASTRAX® FR LD

TYPE	NUMBER	FUNCTION	DESCRIPTION
	21	Interlock Override	Opens the door and overrides any standard interlock configuration
OUTPUT	0	Interlock	ON when door is closed.
	1	Interlock N.C.	OFF when door is closed.
	2	Pre-announce	ON during pre-announce to close, and stays on until the door is closed.
	3	Open	ON when door is open.
	4	Open N.C.	OFF when door is open.
	5	Fault	ON during fault.
	6	Ready	ON when not in fault.
	7	Activation	ON during activation.
	8	Run Open	ON during run open.
	9	Run Close	ON during run close.
	10	Run	ON during run open or close.
	11	At Limits	ON when door is open or closed.
	12	I-Zone Alarm	ON during I-Zone alarm.
	13	Door Open 30 sec.	ON when door is open for more than 30 seconds.
	14	Door Open 60 sec.	ON when door is open for more than 60 seconds.
	15	Door Open 120 sec.	ON when door is open for more than 120 seconds.
	16	Sequential Activation	ON to activate opposite door. Use for sequential interlock.
	17	Run Open N.C.	OFF during run open.
	18	Run Close N.C.	OFF during run close.
	19	Run Close N.C.	OFF during run open or close.
	20	Disabled	Always OFF.
	21	Flash 3.1 Hz	Flashes at 3.125 Hz.
	22	Flash 1.6 Hz	Flashes at 1.5625 Hz.
23	Partial Timer	Consult Engineering	
OUTPUT (cont.)	24	Reverse / Activation	ON when any reverse command or activation signal is on.
	25	Door Open Alarm	ON when door has been opened for time set in "Open Alarm Time."
	26	Interlock Pass-Thru	ON when door is able to be opened (Interlock Input is not preventing door from opening).
	27	Interlock Pass-Thru N.C.	OFF when door is able to be opened (Interlock Input is not preventing door from opening).
	28	Pre-announce & Close	ON during pre-announce to close, and while closing. NOTE: This output will turn on while door is closed from Toggle or Close command or re-close timer.
	29	Photoeye Test	ON when emitters are on, OFF to test photoeyes.
	30	Encoder Bit 9	Consult Engineering
	31	Encoder Bit 10	Consult Engineering
	32	Encoder Bit 11	Consult Engineering
	33	Encoder Bit 12	Consult Engineering
	34	Pre-announce to Open	ON during the set pre-announce to open time
	35	Pre-announce N.O. Close	ON only during pre-announce to close. Off during run close.

PROGRAMMING FOLDERS

Use the Enter, Up, Down, Back buttons on the i-COMM to navigate through the folders. To exit system, use back button until “**Door Faulted**” appears.

ENCODER FOLDER

See Encoder Folder Layout Chart to change / view settings.

*** MUST perform encoder setup for door operation.**

I/O SETUP FOLDER

See I/O Setup Layout Chart to change / view settings.

Use to set up Input and Output functions.

TIMER FOLDER

See Timer Layout Chart to change / view settings.

Use to change re-close or pre-announce timer.

GENERAL FOLDER

See General Layout Chart to change / view settings.

Use to set up Clock and Maintenance cycles.

VIEW FOLDER

See View Layout Chart to change / view settings.

Use to view cycle count, fault history, and door information.

LOAD / SAVE FOLDER

See Load / Save Layout Chart to change / view settings.

See Legal information.

Use for programming.

INVERTER FOLDER

See Inverter Layout Chart to change / view settings.

Use to change door speed and torque settings.

I-COMM PROCEDURES

RECLOSE TIMER ADJUSTMENT:

1. Press ENTER button.
2. Use UP button to scroll to TIMER FOLDER. Press enter. Display should read “Set Close Timer”.
3. Press ENTER button.
4. To increase re-close time, press UP button
5. To decrease re-close time, press DOWN button.
6. Press BACK button when complete.

CLOCK ADJUSTMENTS:

1. Press ENTER button.
2. Use UP button to scroll to GENERAL FOLDER. Press enter. Display should read “Clock”.
3. Press ENTER button. Display should read M/D/Y and time.
4. Press UP, set year - press enter, set month - press enter, set day - press enter, set hour - press enter, set minute - press enter.
5. Press BACK when complete.

CHECKING FAULT HISTORY:

1. Press ENTER button.
2. Use UP button to scroll to VIEW FOLDER. Press enter. Display should read “Fault History”.
3. Press ENTER button. Display should read the last fault / flash the date / time it occurred.
4. This displays the last 20 faults.
5. Press BACK when complete.

PROGRAM DOWN LOADING:

1. Turn off power to the door and insert SD card into socket.
2. Turn on power and press ENTER button.
3. Use UP button to scroll to “LOAD / SAVE Folder”, press enter, scroll to “Copy from SD” and press ENTER button.
4. Press the UP button when prompted.
5. If “Choose file...” displays, choose the correct file and press ENTER to start update.
6. After the i-COMM reboots, remove SD card and operate door.

NOTE: When setting Maintenance timer, Open / Reset button will flash slowly when set time / cycles have expired, and display will read **Maintenance Required**.

To reset Maintenance light, press ENTER button; scroll to General Folder, press ENTER button; scroll to Reset Maintenance, press ENTER; then press UP to start, then press BACK button until at MAIN MENU, then press green Open Button. This will reset flashing Open / Reset button.

Fault Code Descriptions		Fault Code Descriptions	
Description	Code	Description	Code
FAULT_NONE	0	FAULT_PHOTOEYE	13
FAULT_POWER_UP	1	FAULT_ENCODER_READ	14
FAULT_BREAKAWAY	2	FAULT_ENCODER_VELOCITY	15
FAULT_RUN_OPEN_TIMER	3	FAULT_ENCODER_NC	16
FAULT_MENU_INT	4	FAULT_VFD_TRIP	17
FAULT_LIMIT_SWITCH	5	FAULT_VFD_COMM_LOSS	18
FAULT_ESTOP	6	FAULT_VFD_NO_PROGRAM	19
FAULT_RUN_CLOSE_TIMER	7	FAULT_EDGE_FAILURE	20
FAULT_LIMIT_PULSE_FAIL	8	FAULT_BAG_UP	21
FAULT_OBSTRUCTION	9	FAULT_ENCODER_NPWR	22
FAULT_TIMER_READ	10	FAULT_LZR	23
FAULT_STATE_OB	11	FAULT_BLANK	255
FAULT_PRO_SYSTEM	12		

230/460V INVERTER (VFD) PROGRAMMING

FasTrax™ Inverter Program Instructions

*****These instructions are only when not using the i-Comm to change parameters.*****

When in Status mode, pressing and holding the “M” MODE key for 2 seconds will change the display from displaying a speed indication to displaying load indication and visa versa.

Pressing and releasing the “M” MODE key will change the display from status mode to parameter view mode. In parameter view mode, the left hand display flashes the parameter number and the right hand display shows the value of that parameter. Pressing and releasing the “M” MODE key again will change the display from parameter view mode to parameter edit mode. In parameter edit mode, the right hand display flashes the value in the parameter being shown in the left hand display. Pressing the “M” MODE key in parameter edit mode will return the drive to the parameter view mode. If the “M” MODE key is pressed again then the drive will return to status mode, but if either of the “UP” or “DOWN” keys are pressed to change the parameter being viewed before the “M” MODE key is pressed, pressing the “M” MODE key will change the display to the

parameter edit mode again. This allows the user to very easily change between parameter view and edit modes while commissioning the drive.

“WARNING: Consult factory before changing any parameters not listed in this table.”

230/460V INVERTER (VFD) CODES

FasTrax—Inverter (VFD) Status Modes		
Left Display	Status	Explanation
rd	Drive ready	The drive is enabled and ready for a start command. The output bridge is inactive.
ih	Drive inhibited	The drive is inhibited because there is no enable command, or a coast to stop is in progress or the drive is inhibited during a trip reset.
Er	Drive has tripped	The drive has tripped. The trip code will display in the right hand display.
dC	Injection braking	DC injection braking current is being applied to the motor.
Fr		Drive output frequency in Hz
SP		Motor speed in RPM
Ld		Load current as a % of motor rated load current
A		Drive output current per phase in A

FasTrax—Inverter (VFD) Error Codes			
No.	Trip code	Condition	Possible cause
1	tr UU	DC bus under voltage	Low AC supply voltage, check power source. Low DC voltage when supplied by an external DC power supply
2	tr OU	DC bus over voltage	The DC bus (Pr. 84) has exceeded 800V-460V or 400V-230VAC. Check the following: If DC bus climbs while door is not running, disconnect CE filter with power off. If fault is intermittent when door is not running try to set Automatic reset of faults. (PR. 73 = 10.34, PR. 74=10.36, PR. 63 = 3, PR 64 = on) If fault is while door is closing add braking resistor, see Control Box Explosion for a list of parts. Deceleration rate set too fast for the inertia of the machine. Mechanical load driving the motor
19	tr lt.br	I ² C on braking resistor	Check door closing speed. If fault is while door is closing, add braking resistor. See tr OV for more troubleshooting.
20	tr lt. AC	I ² C on drive output	Check that radial spacing and that they are square, or lower track spacing. Motor wiring: check for loose connections or shorts. Make sure door cannot move if brake is engaged.
3	tr OI.AC	Drive output instantaneous over current	Door is mechanical binding or jammed. Check radial spacing and that they are square, or lower track spacing. Motor wiring, check for loose connections or shorts. Make sure door cannot move if brake is engaged. Disconnect CE filter with power off. Insufficient ramp times. Phase to phase or phase to ground short circuit on the drives output. Drive requires auto-tuning to the motor. Motor or motor connections changed, re-auto tune drive to motor MUST wait 10 seconds to reset after trip occurs
4	OI.br	Braking resistor instantaneous over current	Excessive braking current in braking resistor Braking resistor value too small. MUST wait 10 seconds to reset after trip occurs
7	O.SPd	Over speed	Excessive motor speed (typically caused by mechanical load driving the motor)
18	tunE	Auto tune stopped before complete	Run command removed before auto-tune complete
19	lt.br	I ² -t on braking resistor	Excessive braking resistor energy
20	lt.AC	I ² -t on drive output current	Excessive mechanical load. Drive requires re-auto tuning to motor. High impedance phase to phase or phase to ground short circuit at drive output.
21	O.ht1	IGBT over heat based on	Overheat software thermal model drives thermal model
22	O.ht2	Over heat based on drives heat-sink	Heat-sink temperature exceeds allowable maximum

Continued on the next page

FasTrax—Inverter (VFD) Error Codes			
No.	Trip code	Condition	Possible cause
24	th	Motor thermistor trip	Excessive motor temperature
26	O.Ld1	User +24V or digital output overload	Excessive load or short circuit on +24V output The Enable/Reset terminal will not reset an O.Ld1 trip. Use the Stop/Reset key.
	OUL.d	I x t overload	Reduce motor current
	hot	Heat-sink/IGBT temp is high	Reduce ambient temperature or reduce motor current
	br.rS	Braking resistor overload	See Advanced user guide
31	EEF	Internal drive EEPROM failure	Possible loss of parameter values
32	PH	Input phase imbalance or input phase loss	One of the input phases has become disconnected from the drive.
33	rS	Failure to measure motors	Motor too small for drive stator resistance. Motor cable disconnected during measurement.
189	O.cL	Overload on current loop input	Input current exceeds 25mA
	tr HF ##	Hardware Fault	The drive has detected a hardware problem; verify wiring is correct. This cannot be fixed in the field. Replace the drive.
	HF 05 trip		No signal from DSP at start up
	HF 06 trip		Unexpected Interrupt
	HF 07 trip		Watchdog failure
	HF 08 trip		Interrupt crash (code overrun)
	HF 11 trip		Access to the EEPROM failed
	HF 20 trip		Power stage—code error
	HF 21 trip		Power stage—unrecognized frame size
	HF 22 trip		OI failure at power up
	HF 25 trip		DSP Communications failure
	HF 26 trip		Soft start relay failed to close, or soft start motor failed, or braking IGBT short circuit at power up
	HF 27 trip		Power stage thermistor fault
	HF28 trip		DSP software overrun
	HF xx trip		HF 1-4, 9-10,12-19,23,24,29,30 Are not used

575V INVERTER (VFD) PROGRAMMING

FasTrax™ Allen Bradley - 575V - Inverter Program Instructions

“WARNING: Consult factory before changing any parameters not listed in this table.”

Press **“ESC”** once to display the Display Group parameter.

Press **“ESC”** again to enter the group menu; the group letter will flash. Press **“UP”** or **“DOWN”** arrow to scroll through the group menu.

Press **“Enter”** or **“Sel”** to enter a group. Press **“UP”** or **“DOWN”** arrow to scroll through the group menu.

Press **“Enter”** or **“Sel”** to view the value of the parameter. Press **“ESC”** to exit without making any changes.

Press **“Enter”** or **“Sel”** to edit parameter; when # is flashing (Program LED will illuminate if parameter can be edited). Press **“UP”** or **“DOWN”** arrow to change value.

Press **“Enter”** when completed to save changes. Press **“ESC”** to exit and return to program list.

Parameter Number	Name	Default Value	New Value
039	Accel Time	0.5	a/r
040	Decel Time	0.3	a/r
056	Torque Detection Level	70.0	a/r
072	Open Speed	70.0	a/r
073	Approach Open Speed	40.0	a/r
075	Close Speed	17.0	a/r
080	DC Brake Injection Time	0.5	a/r
081	DC Brake Injection Level	1.50	a/r
101	Program Lock	1	0

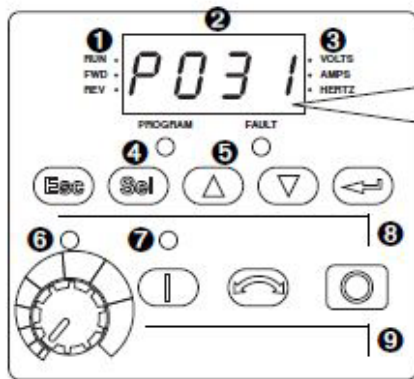

Menu	Description
d	Display Group (View Only) Consists of commonly viewed drive operating conditions.
P	Basic Program Group Consists of most commonly used programmable functions.
A	Advanced Program Group Consists of remaining programmable functions.
F	Fault Designator Consists of list of codes for specific fault conditions. Displayed only when fault is present.

No.	LED	LED State	Description
1	Run/Direction Status	Steady Red	Indicates drive is running and commanded motor direction.
		Flashing Red	Drive has been commanded to change direction. Indicates actual motor direction while decelerating to zero.
2	Alphanumeric Display	Steady Red	Indicates parameter number, parameter value, or fault code.
		Flashing Red	Single digit flashing indicates that digit can be edited. All digits flashing indicates a fault condition.
3	Displayed Units	Steady Red	Indicates the units of the parameter value being displayed.
4	Program Status	Steady Red	Indicates parameter value can be changed.
5	Fault Status	Flashing Red	Indicates drive is faulted.
6	Pot Status	Steady Green	Indicates potentiometer on Integral Keypad is active. ⁽¹⁾
7	Start Key Status	Steady Green	Indicates Start key on Integral Keypad is active. The Reverse key is also active unless disabled by A095 [Reverse Disable].

No.	Key	Name	Description
8		Escape	Back one step in programming menu. Cancel a change to a parameter value and exit Program Mode.
		Select	Advance one step in programming menu. Select a digit when viewing parameter value.
		Up Arrow Down Arrow	Scroll through groups and parameters. Increase/decrease the value of a flashing digit. Used to adjust internal frequency of IP66, NEMA/UL Type 4X rated drives <i>only</i> when a Display Group parameter is shown and P038 [Speed Reference] is set to internal frequency, A069 [Internal Freq].
		Enter	Advance one step in programming menu. Save a change to a parameter value.
9		Potentiometer ⁽¹⁾	Used to control speed of drive. Default is active. Controlled by parameter P038 [Speed Reference].
		Start	Used to start the drive. Default is active. Controlled by parameter P036 [Start Source].
		Reverse	Used to reverse direction of the drive. Default is active. Controlled by parameters P036 [Start Source] and A095 [Reverse Disable].
		Stop	Used to stop the drive or clear a fault. This key is always active. Controlled by parameter P037 [Stop Mode].

⁽¹⁾ IP66, NEMA/UL Type 4X rated drives are not equipped with a potentiometer.

CHAPTER 5

DOOR OPERATION

1. It is recommended that the operation of all controls on the FasTrax be verified monthly.
2. The door operations are controlled by a Universal Controller (i-Comm). The controller is set-up and programmed during testing at the factory. Unless you are a **RITE-HITE DOORS, INC.** authorized service technician, you should not attempt to change the programming.
3. A quick way of determining that the door is ready to operate is to open the control box and look at the row of (X) green Input LEDs on the i-COMM and the label to verify proper state, [page 41](#).
4. Are the pillow block bearing set screws tightened to 66 to 80 in.-Lb [7.5 to 9 N-m]?
5. All wires connected for the photoeyes?
6. Are loose wires secured away from moving parts?
7. With the power on, press the “OPEN” button. The door should open and close automatically after a short delay. To adjust the amount of door open time, the setting must be changed in the i-Comm controller.
8. Operate and observe the door opening to make sure that it fully opens. Observe the closing action to make sure that the door operates smoothly, and fully closes without excessive curtain ripple. Black edging of curtain should not impact the floor.
If it is necessary to adjust either position, refer to Encoder adjustment section.
9. While the door is closing, block the reversing photoeyes. The door should reverse direction and move to the open position, and then continue to operate.
10. Using end user material handling equipment, approach door slowly and verify that all the activation devices that are being used are operating properly. **DO NOT** attempt to drive through a door in which the green button is flashing.
11. Use caution (honk horn) and look in all directions when approaching a door that is closing and ensure that the door will reverse before proceeding.
12. Pedestrians should be advised to use man doors when present and to not lean into the doorway.
13. A fault will occur if the optional non-powered chain hoist chain is pulled. Press the green flashing “OPEN/RESET” button to return to normal operation.

 **WARNING**

Failure to restrict the curtain speed can result in damage to product or injury to personnel. The curtain may close very quickly if the brake is fully released. Releasing the brake partially will allow the door to close smoothly.

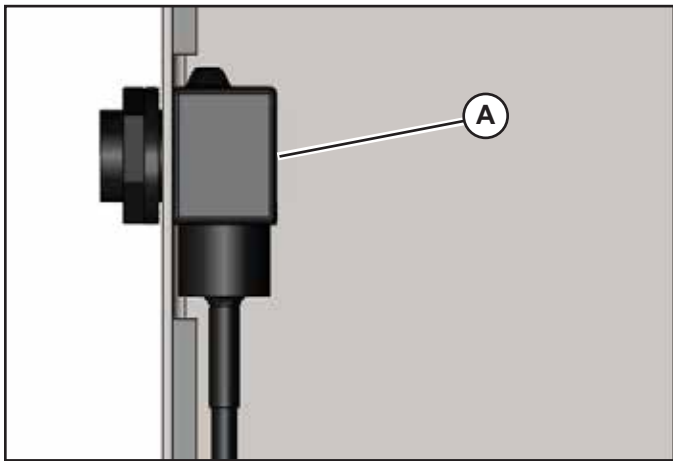

Figure 5-1

Locate the receiver photoeye (A) on the drive side lower track. Located on the top of the photoeye are three LEDs.

The yellow LED will be on when the output is energized. The orange LED will be on when the margin is > 2.5. If the yellow and green LED's are OFF, either the beam is blocked or the photoeye is out of alignment.

The green LED should be on when the photoeye is powered and blocked causing the yellow and orange light to go off.

The source photoeye on the non-drive lower track will only have the green LED for power.

DO NOT change the location of photoeyes. They MUST be at 18" [457 mm] and 54" [1372 mm] as they are disabled before the curtain passes by.

On doors < 43" [1092 mm] O.D.H., the 54" [1372 mm] photoeye is omitted.

On doors > 68" [1727 mm] O.D.H, but < 43" [1092 mm] O.D.H., the 54" [1372 mm] photoeye is lowered to 35" [889 mm].

POWER OUTAGE PROCEDURE

Follow Lock Out Tag Out Procedures to prevent the door from operating should power be restored while working on.

Counterweight or thru-wall brake release is not available.

A Non-Powered Manual Open Option is suggested if opening or closing the door in the event of a power outage is of concern.

In the event of a power outage:

WITH CHAIN HOIST:

1. On the door mounted side, pull the manual brake release chain and lock in the hold down bracket.
2. Pull the chain hoist chain to raise or lower the door.
3. Pulling the chain hoist chain cuts power to the door via a mechanical limit switch. Upon power restoration, repositioning of the chain may be required to reset the door.
4. Release the brake chain to hold the door in place and to put door back in operation mode.

WITHOUT CHAIN HOIST:

1. This procedure should only be performed by trained technicians.
2. On the door mounted side, a ladder or a scissors lift will be required to release the brake.
3. While the brake is released turn the roller tube to lower the door. The force required will vary based on lift configuration.
4. Caution should be used with lift configurations where the weight of the curtain may cause the curtain to rapidly close.
5. The roller tube can be turned by hand or a wrench placed on the non-drive shaft and turned.

FINAL CHECKLIST

Complete	N/A	Description
		Control box conduit mounting location (must be on the bottom)
		Ground wires properly terminated to ground terminal
		Shield wires properly terminated to ground terminal
		Motor ground wire terminated to lower track ground screw
		Encoder chain / sprockets / set screws properly aligned & tightened
		Encoder cable tightened properly
		Lower track properly spaced
		Lower tracks caulked
		Lower tracks square to wall
		Lower tracks shimmed properly if jamb cap present
		Wall mounting brackets securely fastened to wall
		Photoeye wires properly secured to track or wall
		Tracks / Radials lubricated
		Track / Spreader bar in place (Radial or Non-Radial)
		Upper track properly spaced
		Upper track properly braced to wall
		Drive tube level and evenly spaced
		Lintel roller(s) installed properly (Non-FR)
		Proper mounting fasteners used
		Motor terminal strip securely fastened to motor bracket
		Motor bumpers properly adjusted
		Security chain in place
		Drive shroud installed
		Radial center shroud properly installed (Radial only)
		Chain hoist properly installed (Optional)
		If less than 8' tall, make sure drive gear guards are in place (Optional)
		Poly lumber properly installed (Optional)
		FR only– Air bag not kinked, exhausting air, ice free and touching the floor
		FR only – Blower(s) properly mounted
		FR only – Curtain fan(s) properly installed
		FR only – Step-down transformer and junction box properly installed and thru bolted if necessary
		Area clean of debris from installation
		Notes:

CHAPTER 6

OPTIONAL BRAKE RELEASE / CHAIN HOIST

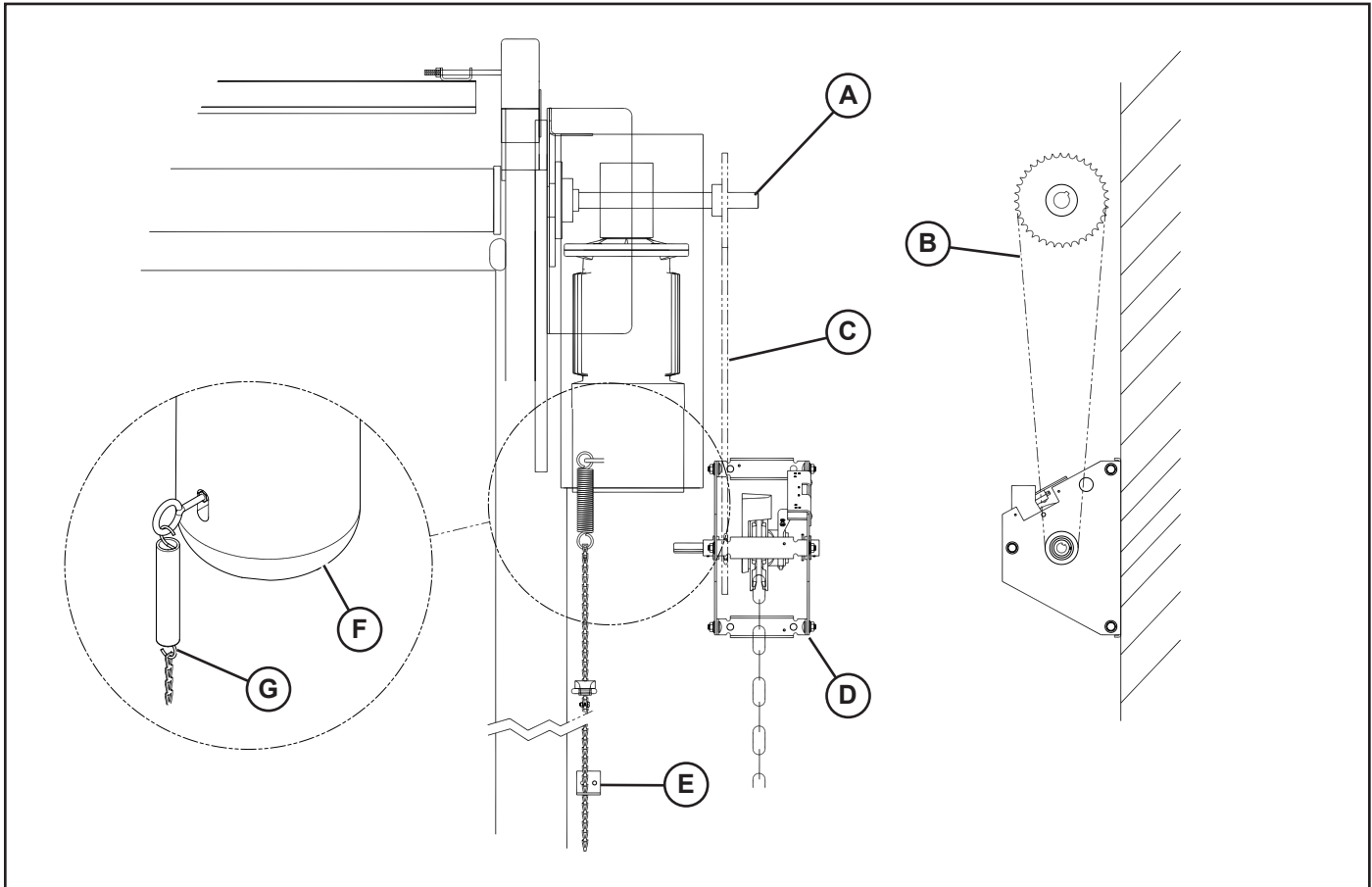

Figure 6-1

1. Lubricate drive shaft (A) with an anti-seize lubricant. Place sprocket onto shaft and tighten set screws.
2. Route chain (B) around sprockets. Plumb and level chain hoist, make sure chain is taut.
3. (C) Use a straight edge to align chain sprockets. Failure to do so may result in noise and premature wear.
4. Mark and drill hole locations and fasten hoist (D) to the wall. Unit can be rotated 180° to fit.
5. Attach spring (G) to the brake (F) handle and chain to the spring.
6. Fasten chain lock bracket (E) to wall so that it will hold chain in place to release the brake. Trim excess chain.

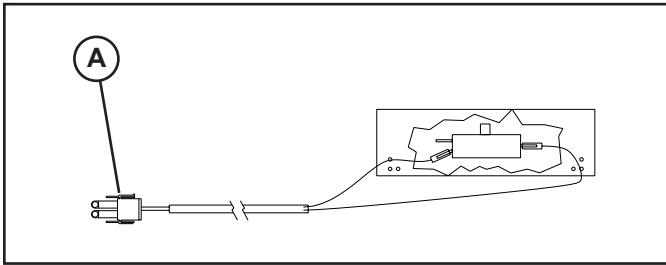

Figure 6-2

7. Plug in cable (A) and wire chain hoist into control box per electrical drawings on [pages 75—76](#).

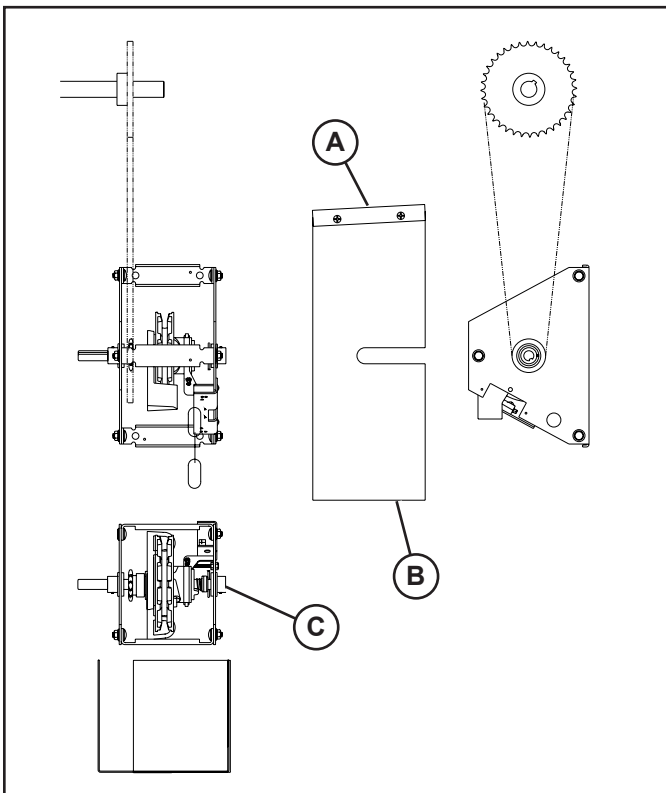

Figure 6-3

8. Install interior chain hoist guard (A).
9. For opposite drive, remove top bracket (B), rotate 180° and refasten.
10. Test operation of chain hoist (C):
 - a. Pull brake chain and lock in place.
 - b. Pull chain hoist chain, which will stop door operation.
 - c. Release brake chain and operate door.

OPTIONAL WELD PLATE INSTALLATION

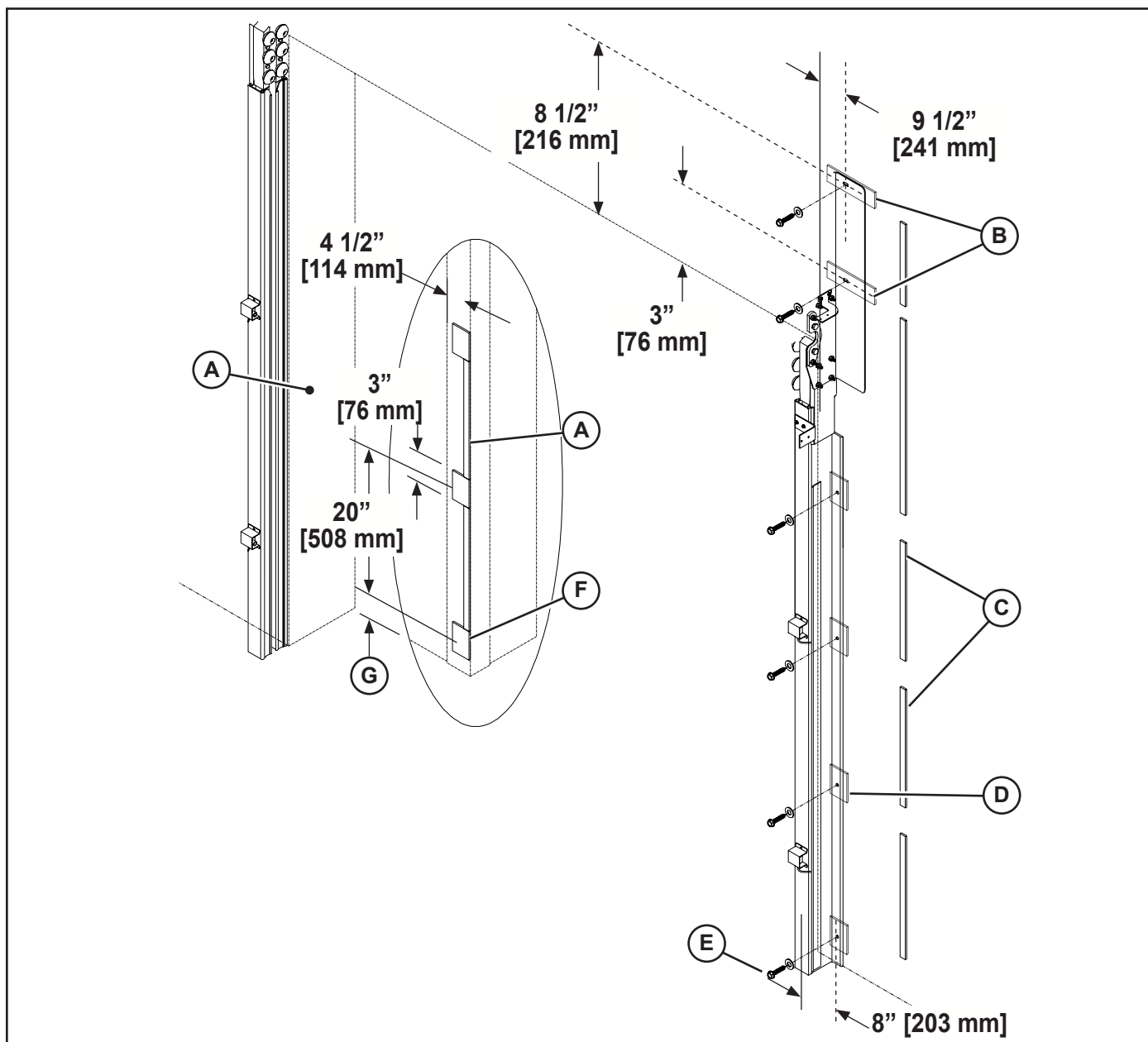

Figure 6-4

1. Measure from bottom of track to each hole location and position weld plates (B, D, F) on the steel jamb (A) at these locations and weld in place. If steel is not present at the track hole locations, weld where possible. Distance (G) varies based on O.D.H.
NOTE: There *MUST* be a fastener every other hole minimum, approximately 4' [1219 mm].
2. Position upper weld plates (B) so they catch the wall mount bracket holes. If no steel exists above the opening, it must be provided.
3. Fasten lower track to weld plates with self-drill/tap screws and washers provided (E).
4. Fill gaps between weld plates with tape-backed foam (C).

LABELS / I-ZONE / SHROUD

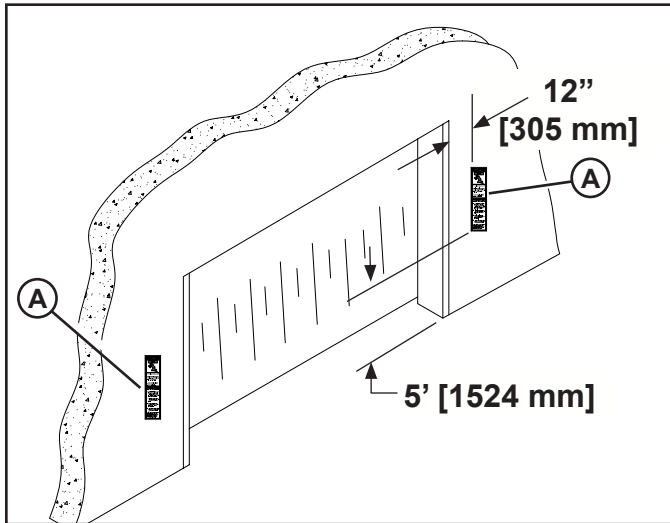

Figure 6–5: Label(s) on Back Side of Door

Clean surface where label (A) is to be placed. Peel off backing on label and apply in position.

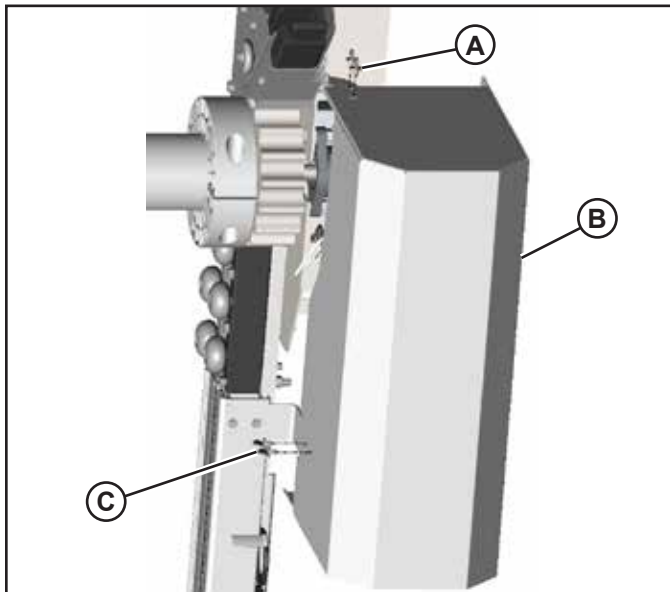

Figure 6–6: Drive Shroud Installation

1. Align extension bracket slots with holes in drive shroud and attach to upper mounting bracket with (2) thumb screws (A).
2. Place drive shroud (B) into position and attach to lower mounting bracket with (2) thumb screws (C).

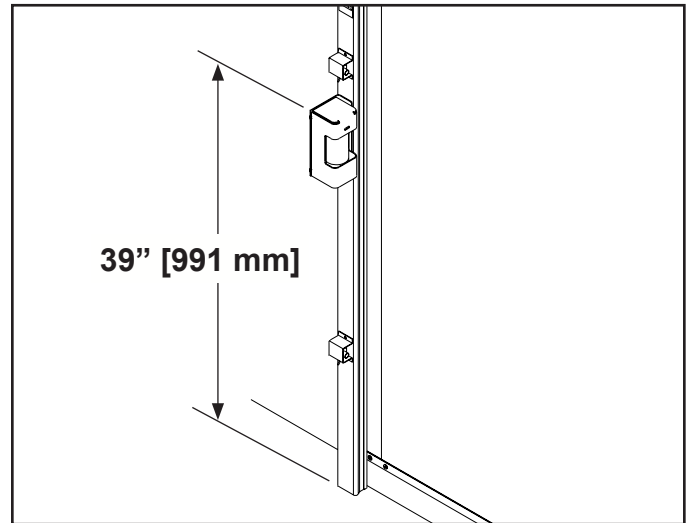

Figure 6–7: Optional I-Zone Sensors

1. Mount I-Zone sensors to the lower tracks and route cables to the control box.

NOTE: If Exterior / Exterior door, the I-Zone sensors **MUST** be mounted on the inside of the building.

2. Lights on sensor will flash for 30 seconds on power up.
3. Alarm should be tested by removing the plastic cover from one of the I-Zone sensors. After 30 seconds the alarm will sound. (Door should be in the open position during this test.)

CHAPTER 7

MAINTENANCE PROCEDURES

RITE-HITE DOORS, INC. PLANNED MAINTENANCE Model FASTRAX® FR LD								
Customer:	Job #	Serial #						Date:
Planned Maintenance Task	Recommended P.M. Intervals							Inspect and Perform the Following
	(Time Shown in Months)							
	1	6	12	18	24	30	36	
Activation		x	x	x	x	x	x	Operate all devices to verify proper operation.
Curtain Fans		x	x		x		x	Verify that curtain fans are powered and working. Make sure that the fans are positioned properly and are removing condensation from the curtain.
Auto Re-Feed		x	x		x		x	Verify auto re-feed is operational.
Brake	x		x		x		x	Verify that brake stops the door at open and closed positions as well as when stopped in the middle of travel. To move the curtain manually, turn the brake release handle to the disengaged position. The curtain should be able to be moved manually. If brake is making noise, adjust.
Controls / Wiring			x		x		x	Clean and check all connections with disconnect off. Make sure all wires are free from moving parts.
Curtain		x		x	x		x	Inspect for wear or damage; patch immediately to prevent condensation or frost buildup. Clean with warm soapy water. Check drive spheres; if missing or damaged, replace. Check top roller. Refer to “Curtain Installation” on page 34.
Door Assembly			x		x		x	Perform visual inspection for damage. Tighten all hardware. Replace any worn labels. Use air hose to remove dust and debris.
Door Operation			x	x	x	x	x	Operate door and make sure all operations are functioning properly.
Drive Tube			x		x		x	Verify drive tube gear is centered over track groove. Make sure bearing set screws and mounting bolts are tight.
Gearbox			x		x		x	Check gearbox fluid level; fill with Mobil - SHC 624 or Phillips 66 - Syncon 32 if low. Check lock collar set screws.
Encoder / Chain / Sprockets			x		x		x	Verify encoder chain and sprocket set screws are tight. Verify lock collar on encoder is tight. Check open and close positions; adjust as required.
Curtain Bottom Seal			x		x		x	Verify lintel seal is sealing wall properly.
Motor			x		x		x	Check junction box and plug connections.
Non-Powered Opening (optional)			x		x		x	With power off, verify chain hoist opens door. Lubricate chain, sprockets and check alignment.
Photoeyes			x	x	x	x	x	Verify both photoeyes reverse the curtain. LEDs on receiver should go on/off. Clean emitter and receiver lens.
Thermal Air Seal		x	x		x		x	Verify air bag is inflated, free of tears and providing an adequate seal against curtain and the wall. If torn, patch immediately to prevent condensation build-up. Verify warm air existing exhaust holes.
Tracks / Radial (upper and lower)								Perform visual inspection. Lubricate radials and tracks with food grade synthetic grease (Super Lube). It may be required to remove the existing grease prior to adding new. Verify proper width and tighten all hardware. Check foam seal if present.
Track Retention Strips			x		x		x	Inspect track retention strips; replace if cracked.
Virtual Vision (optional)			x	x	x	x	x	Verify Virtual Vision is functioning properly. Red LEDs should be lit if movement on opposite side.
Radial and Track Lubrication	Lubrication of radials and tracks may be required more than every 6 months, based on usage and environmental conditions.						Lubrication of the radials and tracks is the sole responsibility of the end user. If door is mounted in a dirty environment, it may be required to remove the existing grease prior to adding new.	

MAINTENANCE INFO

High-Temperature Synthetic Grease with PTFE (Polytetrafluoroethylene)

The synthetic oil base in this food-grade silica-thickened grease increases the time before the next application. It also contains a PTFE additive that reduces friction and waterproofs metal surfaces, preventing rust and corrosion. NSF rated H1 for applications with incidental food contact. Temperature range is -45° to +450° F [-45° to +232° C]. Color is white.

McMaster Carr # 1378K33 - 14.1oz Cartridge

MAINTENANCE ITEMS

BRAKE

TORQUE ADJUSTMENT

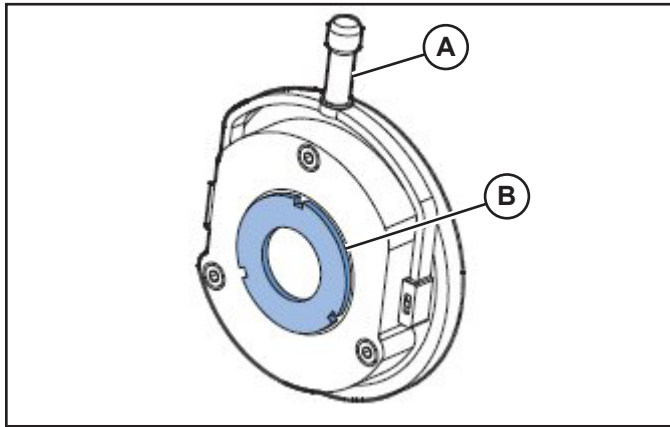

Figure 7-1

This should only be required after prolonged brake use.

Remove the brake cover by removing the three screws and brake handle (A) holding it on.

The spanner nut (B) is tight against the brake casing. To make adjustments, unscrew the spanner nut a few clicks at a time (2.5 turns starting out).

The lower the brake torque, the longer the brake stop time and the faster the brake release time.

Adjustments to the torque setting should not be performed without first consulting RITE-HITE Doors Technical Support at 563-589-2722.

AIR GAP

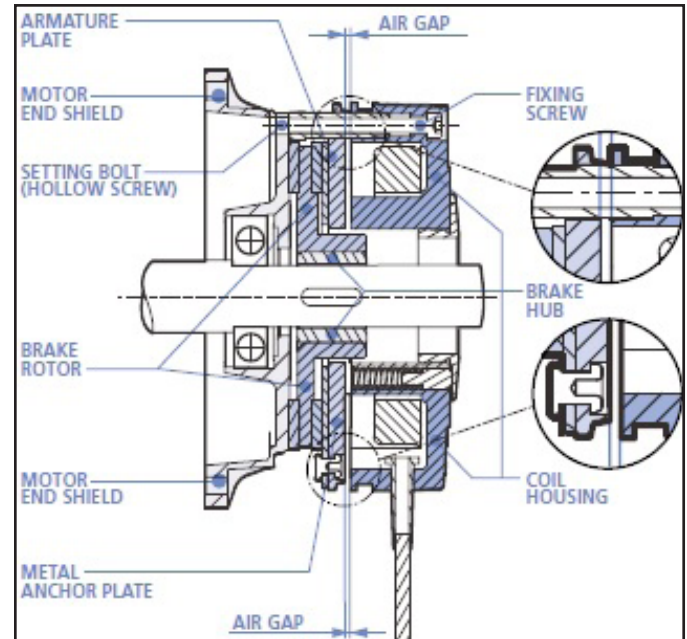

Figure 7-2

The brake air gap is checked by placing a feeler gauge between metal anchor plate and the brake coil housing as shown. Minimum gap is .008" [0.2 mm], maximum is .024" [0.61 mm].

1. Loosen the fixing screws that attach the brake to the motor's end-shield by approximately half a turn.
2. If required, the brake assembly may be loosened slightly from the motor's end shield by turning the threaded setting bolts (hollow screws) that surround the fixing screws, counter clockwise, into the brake coil housing.
3. Depending upon whether or not the air gap needs to be decreased or increased, turn the fixing screws accordingly until the desired

nominal air gap is reached, as measured using the appropriate feeler gauge.

- Turning the fixing screws clockwise allows the brake coil housing to be moved towards the anchor plate and reduces the air gap.
 - Turning the fixing screws counter-clockwise allows the brake coil housing to be moved away from the anchor plate and increases the air gap.
4. If the setting bolts (hollow screws) were adjusted as suggested in Step 2, re-secure the brake coil housing firmly against the motor's end shield by turning the setting bolts (hollow screws) clockwise, out of the brake coil housing.
 5. Tighten the fixing screws to the appropriate torque.
 6. Re-check and measure the air gap in multiple locations to check for appropriate spacing. Repeat the steps as needed until the desired air gap spacing is uniform and consistent all the way around the brake.

2. To disengage brake, remove the chain (B) from the lock bracket (C), pull down and lock the chain in place.
3. To engage brake, rotate bracket horizontal.
4. To engage brake, remove the chain from the lock bracket until chain is no longer taut and lock the chain in place.

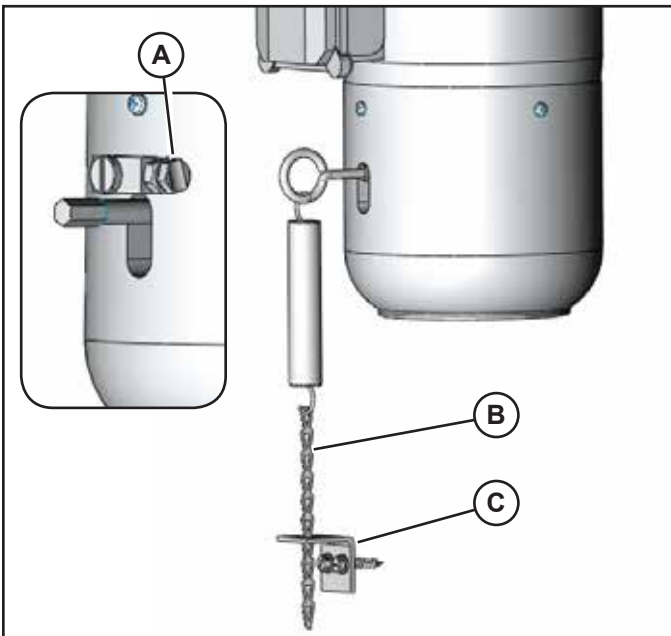
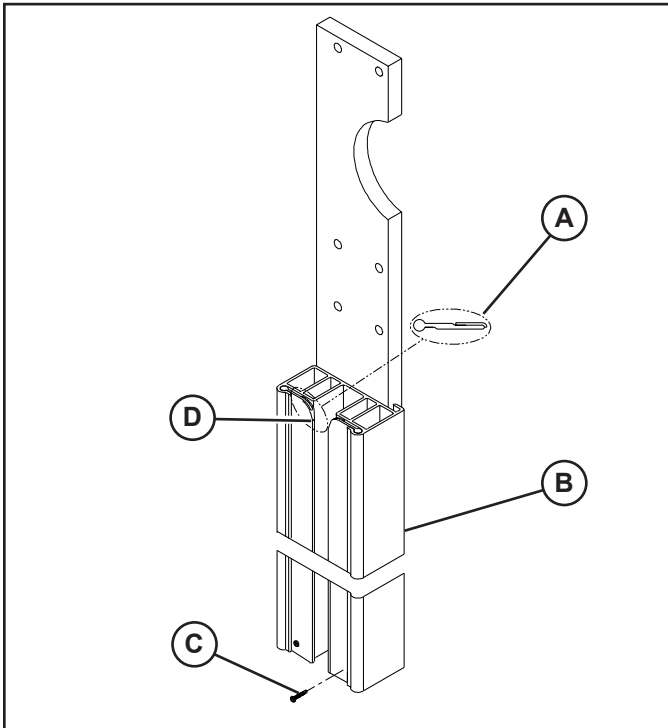

Figure 7-3

1. To hold the brake release (A) on, rotate the brake release hold down bracket to vertical position.



A - Top View Of Edging Replacement

B - Lower Track

C - Screws Holding Edge In Place

D - Retention Strip With J-Strip

Figure 7-4: Retention Strip Replacement

1. Turn power off and follow lock-out tagout procedures.
2. It may be necessary to remove the lower re-feed roller.
3. Remove screws holding in place and slide edging out through the top of the track. Use caution when pulling out so as not to catch on internal photoeyes.
4. Slide new edging into track, make sure not to catch on photoeyes. Align holes with photoeyes.

NOTE: *Per the top view (A), orient the longer leg of the "J" toward the lower track and the groove away from the track.*

5. Fasten edging with screws at the bottom of track. Do Not screw strip to lower track, other than at the bottom.

TROUBLESHOOTING

DEFINITION	FUNCTION
Activation	It is preferred not to wire activation devices until after the door is functioning properly. (Refer to Activation Manual)
Brake	The brake is powered by 110VAC. If brake does not stop door when open or closing or if there is excessive noise, see brake adjustments on page 65 . Brake will have approx. 267 ohms on normal readings; must disconnect from rectifier.
Breakaway	If the curtain is separated from the lower tracks, press the green open/reset button and the door will auto-refeed back into the tracks without tools or intervention. If a major separation occurs the drive tube may need to be turned manually to prevent damage to the curtain.
Control Box Cable	DO NOT DRILL HOLES ON TOP OF THE CONTROL BOX TO RUN CONDUIT AS DUST PARTICLES AND MOISTURE MAY CAUSE DAMAGE TO ELECTRICAL COMPONENTS. THE IDEAL SAFEST LOCATION IS AT THE BOTTOM. Failure to do so will void the warranty. Supplied conduit cable is pre-wired. If it is too short, DO NOT splice wires as the cable is shielded to prevent electrical noise. Make sure the motor is grounded and the braided (drain) wire is properly grounded to prevent electrical noise.
Curtain	The curtain is driven by the drive spheres and the drive tube. a) If drive spheres are missing from curtain, repair or replace. b) If curtain struggles to raise or lower or is baggy, check for proper track spacing: O.D.W. + 1/2" [13 mm]. c) Check to make sure tracks are lubricated with food grade synthetic grease (Super Lube). d) If curtain contacts the wall when closing, verify lower tracks are not too close together and that lintel roller is present.
Disconnect Switch	The disconnect switch is in line with fuse holder terminals F1, F2, F3, and removes power from the entire control box, except for incoming wires to bottom of disconnect.
D.O.H. or D.O.W.	D.O.H. = Door Opening Height or D.O.W. = Door Opening Width
Door does not close	a) Check status on i-Comm display to see why door is staying open (" <i>Photoeye Blocked</i> " or " <i>Photoeye Failure</i> ", etc.). Display should read " <i>Door Closing in 'x' seconds</i> ". b) Verify proper incoming power is reaching inverter at L1, L2 and L3 (220, 230, 400, 460, 575). c) Verify chain hoist chain is not pulled and switch is not tripped. X14 MUST be on; see Non-Powered Opening Definition. d) If run timer occurs, check for binding or obstructions. Tracks may need to be lubricated to reduce friction. e) Verify inputs X3, X5, X6 or X7 are not on. If on, remove wire from terminal to determine what is keeping light on. f) Verify outputs K1, K2, K4, K5 and YDC2 are on or coming on to signal inverter to close door. g) Verify X10 and X11 are on and that the photoeyes are lined up and not blocked. h) Verify as the curtain gets near the photoeyes that they are being shut off. i) If curtain reverses at photoeyes, verify that the photoeye wiring is not reversed. X11 is upper (54" [1372 mm]), X10 is lower (18" [457 mm]). j) Verify inverter display is changing frequency. k) Verify Encoder has been set up. l) Verify rectifier has 120VAC going to it, ~ 100VDC coming out to the brake m) Verify curtain feeds into rollers and edge is not binding.
Door does not open	a) Verify input X3, X5, or X6 are coming on when activation device is being used. b) Verify outputs K3, K4, K5 and YDC2 are on or coming on to signal inverter to open door. c) Check status on i-Comm display to see why door is staying closed. Display should read "Door Opening". d) Verify inverter display is changing frequency. e) Verify proper incoming power is reaching inverter at L1, L2 and L3. f) Verify chain hoist chain is not pulled and switch is not tripped. X14 MUST be on; see Non-Powered Opening Definition.
Door slams open/ close	a) Verify the open and close positions are properly set. b) Verify encoder lock collar and sprocket set screws are tight and the chain moves when the drive tube is turning. c) Verify the encoder shaft turns when the drive tube is turned. d) Verify the inverter is changing speeds on the display. e) Verify the phasing is correct. The door should open when the green open button is pressed. f) Verify the brake is engaged and not released. g) Verify the key been installed on the gearbox shaft. h) Verify the proper ratio gearbox is being used. i) Verify Encoder has been set up. j) Verify rectifier has 120VAC going to it, ~ 100VDC coming out to the brake.
Drain Wire	Verify that drain wire is terminated properly. Failure to properly terminate the drain wire may result in sporadic reversals, photoeye and other issues due to either static electricity or electrical noise and void warranty.
Drive Side Switch	The drive can be switched from right hand to left hand by performing the following: a) Remove and switch conduit mounting bracket to opposite side. b) Remove and switch torque arm bracket. c) Remove and switch drive and non-drive photoeye cables. d) Flip drive tube 180°. e) New drive shroud and bracket are required. f) Set up i-Comm to state the proper right or left hand drive.
Drive Tube	If drive spheres make excessive clicking noise, make sure tube drive gears are centered over track grooves.
Encoder	See Encoder Section. THE ENCODER CABLE SHOULD NEVER BE SPLICED OR EXTENDED. a) If curtain is not stopping at the same position, make sure encoder cable is grounded. b) Verify encoder chain is operating properly and sprocket set screws are tight to shafts. c) See page 46 for i-COMM Encoder errors.
Fuses	F1, F2, F3: Incoming power fuses, must have line voltage across all 3 legs. (Transformer, Inverter, motor) F4, F5: Primary side transformer fuses, must have line voltage across both legs. F6, F7: Secondary side transformer fuses, F6 is 24V (FR only - heated pull cord) and F7 is 120V (power supply & brake).

DEFINITION	FUNCTION
i-COMM™ Controller	The i-COMM controller is a circuit board that controls the actions of the door. There is a digital display that shows the cycles, status and position of the door at any time during its travel. For input and output function signals, refer to chart on page 41 . Settings can be changed for re-close or pre-announce timers, interlocks, special activation commands, among others. Refer to instructional manual included. a) Verify i-Comm is receiving 24VDC from power supply. b) If i-Comm display is blank or hard to see, adjust contrast. c) Input X10 - Lower Photoeye will be on unless photoeye is blocked, not aligned or mis-wired. d) Input X11 - Upper Photoeye will be on unless photoeye is blocked, not aligned or mis-wired. e) Input X14 - Fault needs to be on for the door to operate (chain hoist). f) The door can be set to close from 2 to 255 seconds. Follow i-COMM adjustment instructions.
Inverter	See page 52—page 55 for proper parameter settings.
Motor	If door will not run when given an activation, check the following: a) Check voltage to inverter. b) Check voltage and for loose wires at terminals, U, V, and W. c) 208V-240V motor will have 2.8 ohms on normal readings. d) 400V-480V motor will have 9 -10 ohms on normal readings. e) 575V motor will have 13 ohms on normal readings.
Motor Phasing	If “Open/Reset” button is pressed and the door closes, phasing is reversed; switch wires in terminals, V and W. Make sure the motor is properly grounded to prevent electrical noise.
Non-Powered Opening (NPO)	If issues arise with the non-powered opening chain hoist, check the following: a) If power outage, release brake and pull chain on hoist to open door. b) If chain hoist chain is pulled while door is powered, the door will go into fault mode (green light flashing), no X14. c) If chain hoist chain is pulled, reset door by pressing the green flashing button.
O.D.H. or O.D.W.	O.D.H. = Ordered Door Height or O.D.W. = Ordered Door Width
Open/Reset Push Button	The open/reset push button function is when the button is pressed, a command to open the door is given. To jog door when i-COMM states “Photoeye Failure”, press and hold the “Open/Reset” button.
Pressure	If the curtain is blowing out because of high wind or negative pressure, check the following: a) Tracks MUST be mounted at O.D.W. + 9” [229 mm]. If mounted wider, excessive curtain wear may occur. If too narrow, curtain buckling or billowing will be greater. b) Check to make sure the curtain has all the drive spheres in place. c) Verify Lexan Strips are present and functioning properly.
Photoeyes	The photoeyes are wired to the 24VDC circuit and are wired as normally closed when there is power to the unit and the emitter photoeye is aligned with the receiver photoeye. There are 3 lights on the receiver and one on the emitter. Green is for power, yellow and orange are for proper alignment. The photoeyes will reverse or hold the door open when the photoeye beam is blocked. When the beam is not broken, the door will auto-reclose. If photoeyes require adjustment, check that lower tracks are square to the wall. a) Power to Brown (DC) and Blue (OV) wires. b) Internal photoeye relay(wires Black / Blue) should be closed when photoeye is aligned and open when not aligned. c) When open, i-COMM verifies photoeye inputs are off. If on, door will fault. If off, test is ok and emitters turn on. d) Orange and yellow light on the Receiver should be on when aligned. e) Green light on the Emitter indicates the unit is powered up. f) Input X11 will go off when the upper (54”) [1372 mm] photoeye is tripped. g) Input X10 will go off when the lower (18”) [457 mm] photoeye is tripped. h) If two or more doors are back to back, verify they are not reading each other. A plate may be required to separate. i) On doors < 43” [1092 mm] O.D.H., the 54” [1372 mm] photoeye is omitted. j) On doors > 68” [1727 mm] O.D.H, but < 43” [1092 mm] O.D.H., the 54” [1372 mm] photoeye is lowered to 35” [889 mm].
Power Supply	Power Supply is powered by 120VAC from the F7 fuse and delivers 24VDC to the i-COMM.
Tracks	a) Verify tracks are properly spaced. MUST be O.D.W. plus 1/2” [12 mm]. b) Lubricate as required per Maintenance Schedule, page 64 .
Virtual Vision	Virtual Vision is standard on the FasTraxFR door. When motion is sensed via Falcon motion sensors, the Virtual Vision red LEDs will illuminate to notify driver of movement on the opposite side of the curtain. a) It is normal for the YDC1 output to flash on i-COMM during door operation..
Voltage Change	To change the voltage, see steps below: a) Change transformer taps and fuses per electrical diagram. b) Change motor wiring per junction box diagram. c) Replace Inverter with proper voltage. d) Brake resistor e) Change voltage selection on i-COMM

Continued on the next page

FASTRAX® FR LD

DEFINITION	FUNCTION
X0	Input programmed for a device to open the door.
X1	Input programmed for a device to stop the door.
X2, X3, X6, X7	Activation Inputs - If on and door is not closing, verify activation device is not faulty.
X4	Input programmed for a device to close the door.
X5	Input programmed for a device to toggle open / close the door.
X8, X9	I-Zone Inputs
X10	18" [457 mm] Photoeye Input - MUST be on; If off, verify aligned and powered.
X11	54" [1372 mm] Photoeye Input - MUST be on; if off, verify aligned and powered
X12	Open / Reset Button - X12 will illuminate when button is pressed
X13	Induction loop Input - if on door will stay open - verify object is not present on the floor loop
X14	Fault Input - Verify chain hoist chain has not been pulled.
X15	Power Input - Indicates unit is powered
YK0	Interlock output
YK1	Programmable output
YK2	Programmable output
YDC0	Output programmed to be on when door open.
YDC1	Output programmed to flash when virtual vision is functioning
YDC2	Photoeye test, must flash off when door is opening
YDC5	Output programmed for Pre-announce to close.

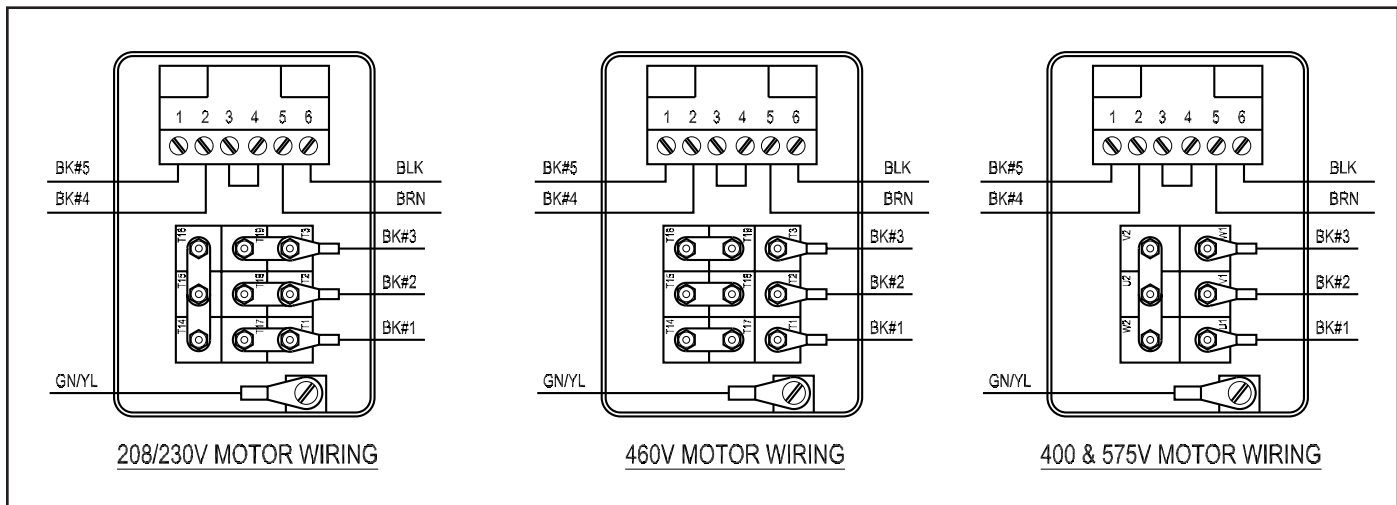
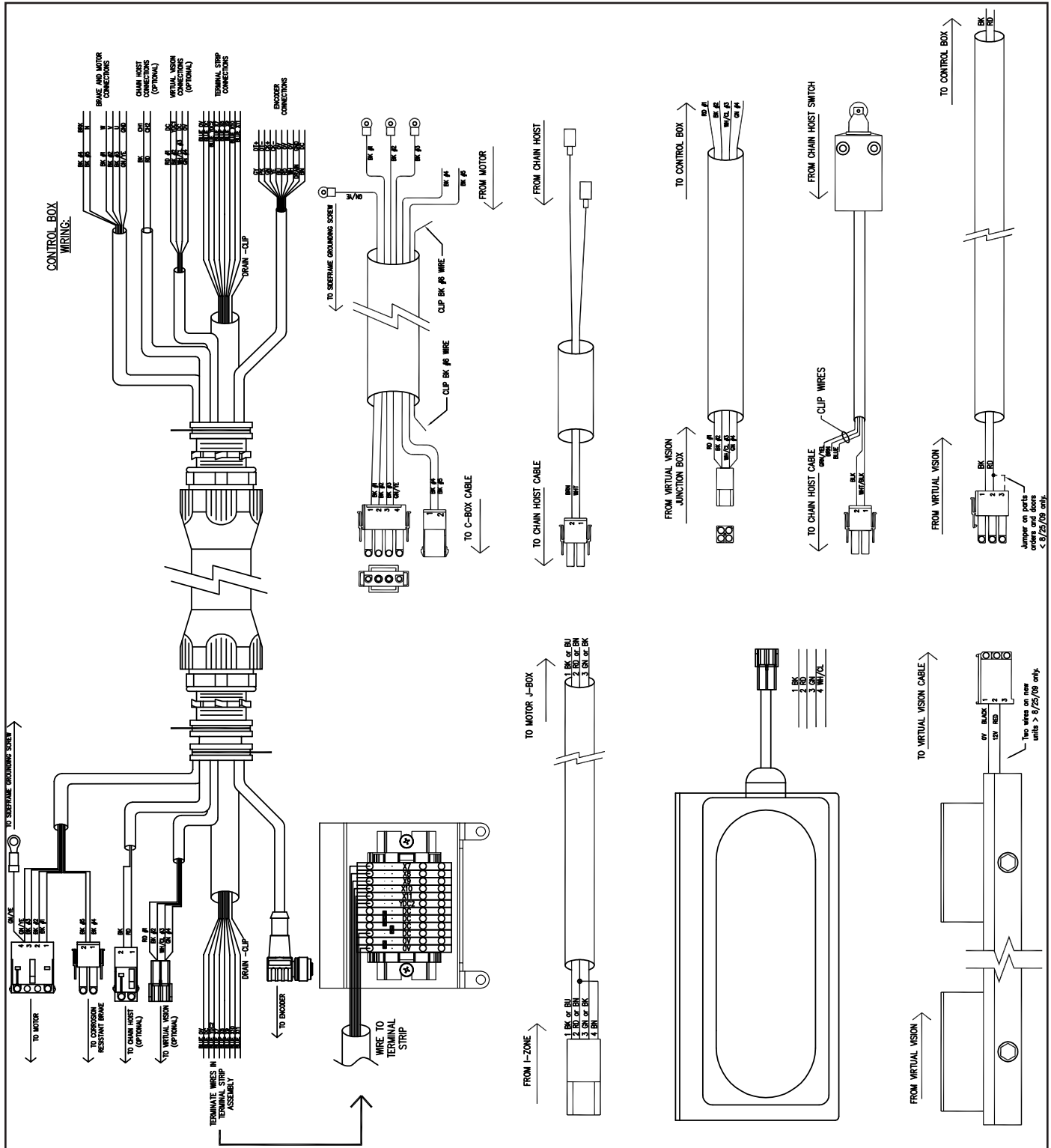

Figure 7-5

ELECTRICAL CABLE IDENTIFICATION



WIRELESS ACTIVATION

It is recommended to pair the unit(s) at the control box prior to mounting the unit.

To pair the host with a wireless device:

1. Open the lid and remove the plastic strip under the batteries in the remote unit to energize the device.
2. On the Host (Receiver) in the control box, press "Remote Pairing". The "RF Com" LED will begin to flash.
3. Within 5 seconds press the pair button on the remote unit. The units will then pair.
4. Activate the door to test. Repeat procedure if necessary.
5. Mount remote unit.
6. Wiring for Host unit to Control Box i-COMM:
 - 4 - X6
 - 5 - DC
 - 6 - DC
 - 7 - OV

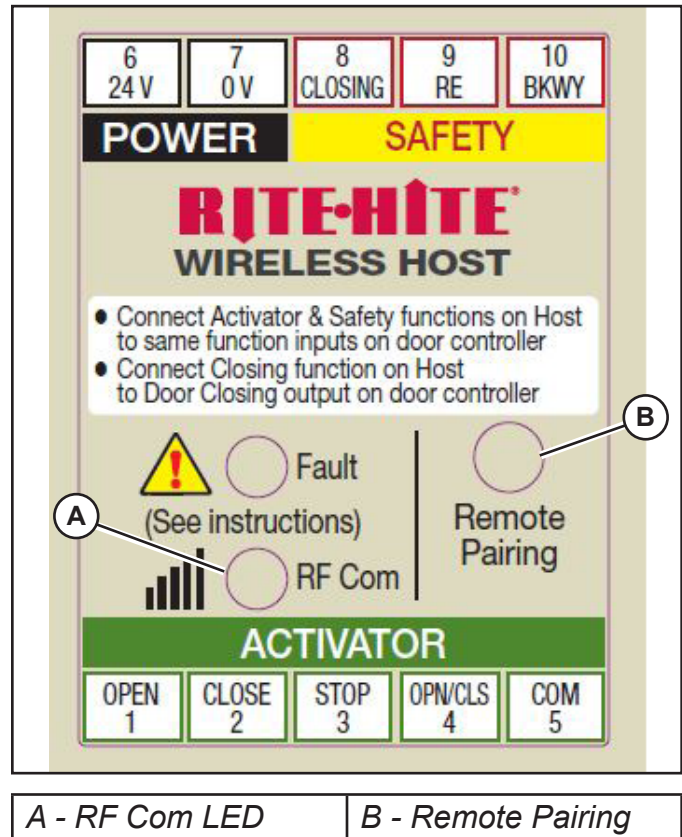

Figure 8-1



A - Plastic Strip

B - Pair Button

Figure 8-2

OPTIONAL REMOTE MOUNTED CONTROLS



Figure 8-3

Optional remote mounted LCD is mounted on a stainless steel 2-gang wall faceplate and compatible with standard 2-gang electrical box (provided by end user).

On the face of the assembly there is a 4 button membrane switch: Green - Open/Reset (Up), Red - Stop (Exit), Yellow - Close (Down), and Grey - Enter (Left arrow).

Press and hold Enter for 5 seconds to enter the menu. The Open button on the membrane switch will reset the door after a fault. The screen flashes when in a fault.

NEXT ASSEMBLY	FINAL ASSEMBLY	REVISION HISTORY				
		REV.	DATE	NOTE	ECN	BY
		A	9/12/2013	RELEASED TO USE	6786	CDH

CONTROL BOX CONNECTIONS

IMPORTANT!
THE PLUGS MUST BE CONNECTED TO THE CORRECT HEADERS. IF NOT CONNECTED PROPERLY, THE REMOTE LCD WILL NOT FUNCTION AND COULD BE DAMAGED.

LCD INTERFACE CONNECTIONS

TERMINALS LOCATED ON LCD DISPLAY (2)

TERMINALS LOCATED ON INTERFACE MODULE (3)

INSTRUCTIONS:
END-USER MUST SUPPLY A STANDARD 2-GANG ELECTRICAL BOX.

- SHUT-OFF POWER TO THE DOOR. USE LOCKOUT/TAGOUT IF REQUIRED.
- FEED THE CABLE THROUGH THE WALL FROM CONTROL BOX TO DESIRED MOUNTING AREA.
- PUNCH A HOLE IN THE ELECTRICAL BOX & FEED THE CABLE THROUGH (NON-CONNECTOR END).
- SECURE THE ELECTRICAL BOX IN THE WALL.
- TERMINATE WIRES AS SHOWN ON THE RIGHT DIAGRAM.
- AT THE CONTROL BOX, PLUG IN THE J46 & J48 CONNECTORS. IMPORTANT! LOOK AT THE WIRE COLORS TO MAKE SURE THE PLUGS ARE MATING WITH THE CORRECT HEADERS.
- POWER UP THE DOOR. IN THE I-COMMIII MENU, ENABLE THE REMOTE DISPLAY. MAIN MENU----->GENERAL FOLDER----->REMOTE DISPLAY----->ENABLED (THIS WILL BE FACTORY SET ON NEW EQUIPMENT ORDERS)
- MAKE SURE THE LCD IS ON & THE MEMBRANE SWITCH FUNCTIONS. ADJUST THE CONTRAST TO THE DESIRED LEVEL WITH THE YELLOW KNOB ON THE BACK OF THE LCD.
- POWER OFF DOOR, & SECURE THE WALLPLATE TO THE ELECTRICAL BOX. MAKE SURE CONDUCTORS ARE NOT PINCHED BETWEEN THE WALLPLATE & ELECTRICAL BOX.
- RESTORE POWER & RESET THE DOOR.

BOM Table

ITEM	QTY.	PART NUMBER	DRAWING	DESCRIPTION
1	1	65000818	9999M261	PLATE,MNT,LCD INTERFACE,STNLS
2	1	51950090	-	DISPLAY,LCD,SC1602,RS485
3	1	65100028	9999M258	DCC,INTERFACE MODULE,I-COMMIII
4	1	72700271	9999M037	SW, MEMBRANE,4BTN,I-COMMIII
5	4	70450173	9999M282	SPACER,NYLON,#4,3/16"ODX3/16"L
6	1	15650305	9999M038	CABLE,REMOTE INTERFACE,I-COMMIII
(NOT SHOWN)	7	1'	75600018	WIRE,22GA,YEL STRD,150V,80DC

<p>CONFIDENTIAL</p> <p>THIS DOCUMENT IS THE PROPERTY OF RITE-HITE® DOORS INC. SUBJECT MATTER HEREIN IS CONFIDENTIAL. DO NOT USE, REPRODUCE, COPY OR DISCLOSE EXCEPT WITH WRITTEN CONSENT OF RITE-HITE® DOORS INC.</p> <p>© 2013 RITE-HITE® DOORS INC.</p>	<p>UNLESS OTHERWISE SPECIFIED DIMENSIONS ARE IN INCHES.</p> <p>TOLERANCES:</p> <p>X = ±.050 XX = ±.010 XXX = ±.005 ANGLE = ±1.0°</p> <p>THIRD ANGLE PROJECTION</p>	<p>MATERIAL</p> <p>DRAWN BY CDH DRAWN DATE 8/27/2013 INITIAL ECN 6786 DATE ISSUED 9/12/2013</p> <p>REFERENCE</p> <p>ALL SHEETS ARE THE SAME REVISION STATUS</p> <p>DO NOT SCALE DRAWING</p>	<p>RITE-HITE® DOORS INC.</p> <p>TITLE</p> <p>LCD INTERFACE,I-COMMIII RELEASED TO PRODUCTION</p> <p>SIZE MODEL DWG NO B 9999M039</p> <p>SCALE 1:1 PART# 55150279 SHEET 1 OF 1</p>
--	--	--	---

MANDATORY FIELD WIRING DIAGRAM <43" O.D.H.

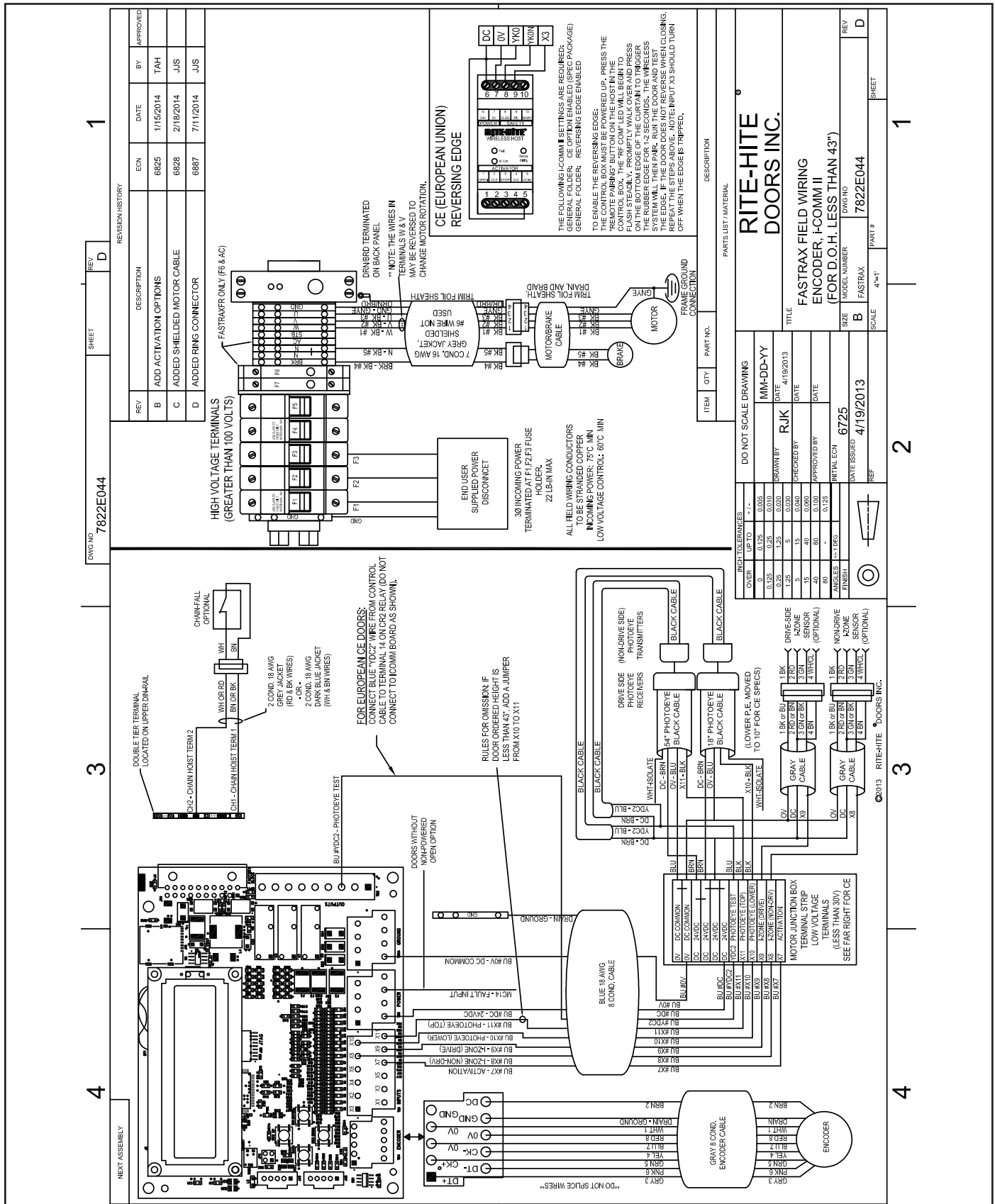

230/460V ELECTRICAL WIRING DRAWING

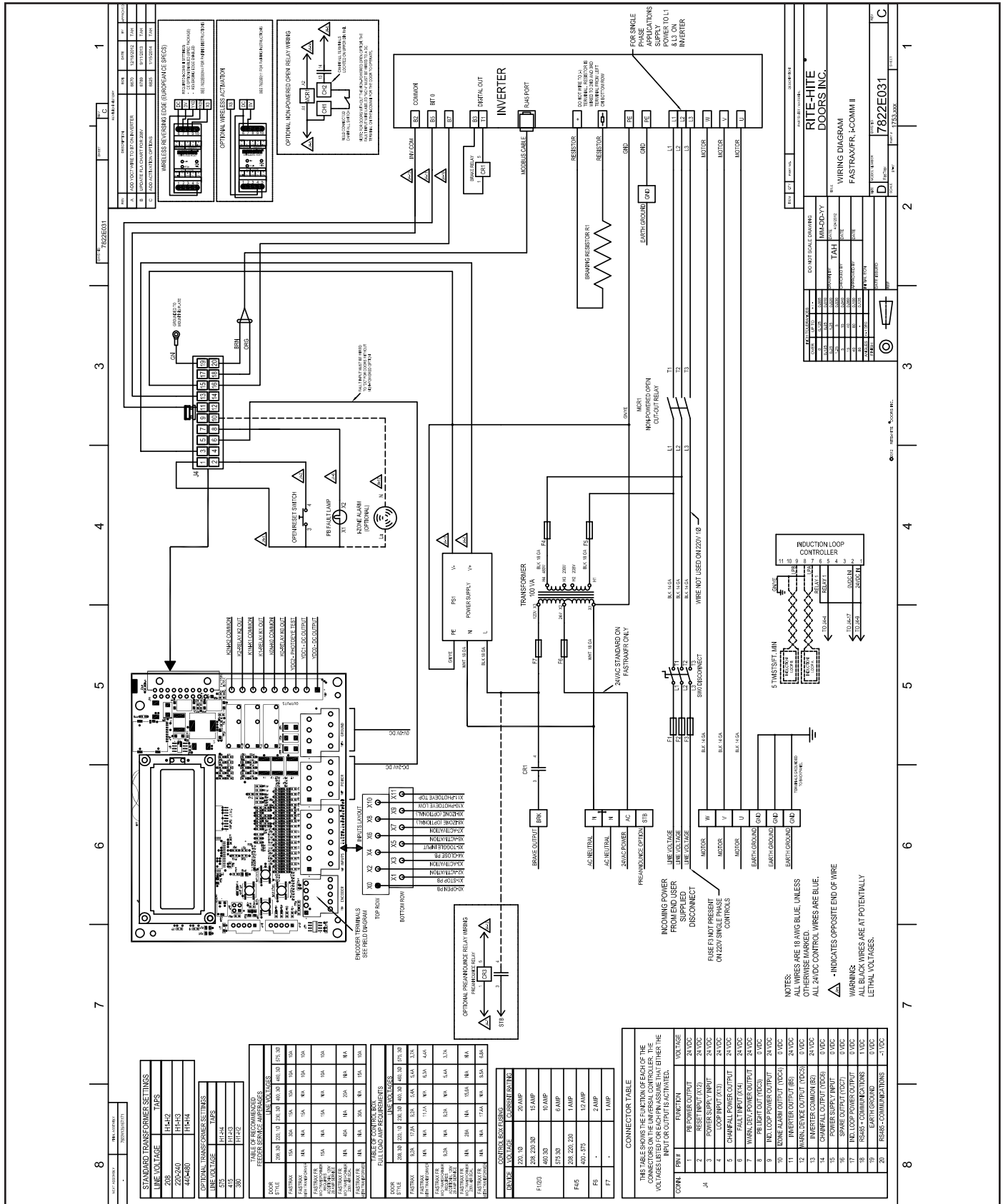

575V ELECTRICAL WIRING DRAWING

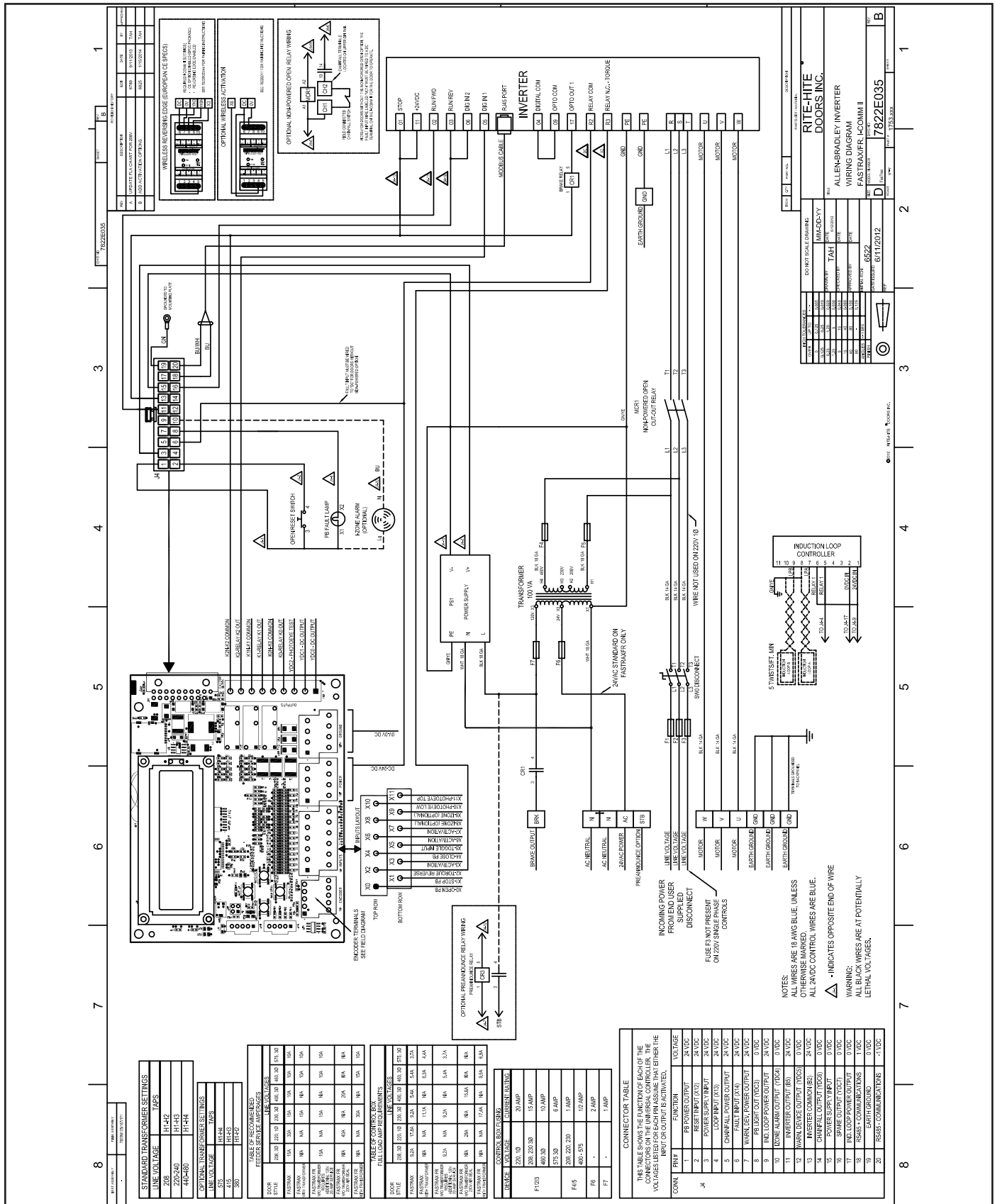

1
2
3
4
5
6
7
8

WIRE GAUGE (EUROPEAN SPECS)

AWG	EUROPEAN SPECS
14	2.0
12	2.5
10	3.0
8	4.0
6	6.0
4	10.0
3	16.0
2	25.0

OPTIONAL WIRELESS RELAY WIRING

WIRELESS RELAY WIRING (EUROPEAN SPECS)

OPTIONAL WIRELESS ACTIVATION

OPTIONAL WIRELESS RELAY WIRING

WIRELESS RELAY WIRING (EUROPEAN SPECS)

OPTIONAL WIRELESS ACTIVATION

OPTIONAL WIRELESS RELAY WIRING

WIRELESS RELAY WIRING (EUROPEAN SPECS)

OPTIONAL WIRELESS ACTIVATION

OPTIONAL WIRELESS RELAY WIRING

WIRELESS RELAY WIRING (EUROPEAN SPECS)

OPTIONAL WIRELESS ACTIVATION

OPTIONAL WIRELESS RELAY WIRING

WIRELESS RELAY WIRING (EUROPEAN SPECS)

OPTIONAL WIRELESS ACTIVATION

TABLE OF RECOMMENDED FEEDER SIZE PER AMPERAGE

DOOR	FEEDER SIZE
200	10 AWG
220	10 AWG
240	10 AWG
260	10 AWG
280	10 AWG
300	10 AWG
320	10 AWG
340	10 AWG
360	10 AWG
380	10 AWG
400	10 AWG
420	10 AWG
440	10 AWG
460	10 AWG
480	10 AWG
500	10 AWG
520	10 AWG
540	10 AWG
560	10 AWG
580	10 AWG
600	10 AWG
620	10 AWG
640	10 AWG
660	10 AWG
680	10 AWG
700	10 AWG
720	10 AWG
740	10 AWG
760	10 AWG
780	10 AWG
800	10 AWG
820	10 AWG
840	10 AWG
860	10 AWG
880	10 AWG
900	10 AWG
920	10 AWG
940	10 AWG
960	10 AWG
980	10 AWG
1000	10 AWG

TABLE OF RECOMMENDED FEEDER SIZE PER AMPERAGE

DOOR	FEEDER SIZE
200	10 AWG
220	10 AWG
240	10 AWG
260	10 AWG
280	10 AWG
300	10 AWG
320	10 AWG
340	10 AWG
360	10 AWG
380	10 AWG
400	10 AWG
420	10 AWG
440	10 AWG
460	10 AWG
480	10 AWG
500	10 AWG
520	10 AWG
540	10 AWG
560	10 AWG
580	10 AWG
600	10 AWG
620	10 AWG
640	10 AWG
660	10 AWG
680	10 AWG
700	10 AWG
720	10 AWG
740	10 AWG
760	10 AWG
780	10 AWG
800	10 AWG
820	10 AWG
840	10 AWG
860	10 AWG
880	10 AWG
900	10 AWG
920	10 AWG
940	10 AWG
960	10 AWG
980	10 AWG
1000	10 AWG

TABLE OF RECOMMENDED FEEDER SIZE PER AMPERAGE

DOOR	FEEDER SIZE
200	10 AWG
220	10 AWG
240	10 AWG
260	10 AWG
280	10 AWG
300	10 AWG
320	10 AWG
340	10 AWG
360	10 AWG
380	10 AWG
400	10 AWG
420	10 AWG
440	10 AWG
460	10 AWG
480	10 AWG
500	10 AWG
520	10 AWG
540	10 AWG
560	10 AWG
580	10 AWG
600	10 AWG
620	10 AWG
640	10 AWG
660	10 AWG
680	10 AWG
700	10 AWG
720	10 AWG
740	10 AWG
760	10 AWG
780	10 AWG
800	10 AWG
820	10 AWG
840	10 AWG
860	10 AWG
880	10 AWG
900	10 AWG
920	10 AWG
940	10 AWG
960	10 AWG
980	10 AWG
1000	10 AWG

TABLE OF RECOMMENDED FEEDER SIZE PER AMPERAGE

DOOR	FEEDER SIZE
200	10 AWG
220	10 AWG
240	10 AWG
260	10 AWG
280	10 AWG
300	10 AWG
320	10 AWG
340	10 AWG
360	10 AWG
380	10 AWG
400	10 AWG
420	10 AWG
440	10 AWG
460	10 AWG
480	10 AWG
500	10 AWG
520	10 AWG
540	10 AWG
560	10 AWG
580	10 AWG
600	10 AWG
620	10 AWG
640	10 AWG
660	10 AWG
680	10 AWG
700	10 AWG
720	10 AWG
740	10 AWG
760	10 AWG
780	10 AWG
800	10 AWG
820	10 AWG
840	10 AWG
860	10 AWG
880	10 AWG
900	10 AWG
920	10 AWG
940	10 AWG
960	10 AWG
980	10 AWG
1000	10 AWG

TABLE OF RECOMMENDED FEEDER SIZE PER AMPERAGE

DOOR	FEEDER SIZE
200	10 AWG
220	10 AWG
240	10 AWG
260	10 AWG
280	10 AWG
300	10 AWG
320	10 AWG
340	10 AWG
360	10 AWG
380	10 AWG
400	10 AWG
420	10 AWG
440	10 AWG
460	10 AWG
480	10 AWG
500	10 AWG
520	10 AWG
540	10 AWG
560	10 AWG
580	10 AWG
600	10 AWG
620	10 AWG
640	10 AWG
660	10 AWG
680	10 AWG
700	10 AWG
720	10 AWG
740	10 AWG
760	10 AWG
780	10 AWG
800	10 AWG
820	10 AWG
840	10 AWG
860	10 AWG
880	10 AWG
900	10 AWG
920	10 AWG
940	10 AWG
960	10 AWG
980	10 AWG
1000	10 AWG

TABLE OF RECOMMENDED FEEDER SIZE PER AMPERAGE

DOOR	FEEDER SIZE
200	10 AWG
220	10 AWG
240	10 AWG
260	10 AWG
280	10 AWG
300	10 AWG
320	10 AWG
340	10 AWG
360	10 AWG
380	10 AWG
400	10 AWG
420	10 AWG
440	10 AWG
460	10 AWG
480	10 AWG
500	10 AWG
520	10 AWG
540	10 AWG
560	10 AWG
580	10 AWG
600	10 AWG
620	10 AWG
640	10 AWG
660	10 AWG
680	10 AWG
700	10 AWG
720	10 AWG
740	10 AWG
760	10 AWG
780	10 AWG
800	10 AWG
820	10 AWG
840	10 AWG
860	10 AWG
880	10 AWG
900	10 AWG
920	10 AWG
940	10 AWG
960	10 AWG
980	10 AWG
1000	10 AWG

TABLE OF RECOMMENDED FEEDER SIZE PER AMPERAGE

DOOR	FEEDER SIZE
200	10 AWG
220	10 AWG
240	10 AWG
260	10 AWG
280	10 AWG
300	10 AWG
320	10 AWG
340	10 AWG
360	10 AWG
380	10 AWG
400	10 AWG
420	10 AWG
440	10 AWG
460	10 AWG
480	10 AWG
500	10 AWG
520	10 AWG
540	10 AWG
560	10 AWG
580	10 AWG
600	10 AWG
620	10 AWG
640	10 AWG
660	10 AWG
680	10 AWG
700	10 AWG
720	10 AWG
740	10 AWG
760	10 AWG
780	10 AWG
800	10 AWG
820	10 AWG
840	10 AWG
860	10 AWG
880	10 AWG
900	10 AWG
920	10 AWG
940	10 AWG
960	10 AWG
980	10 AWG
1000	10 AWG

TABLE OF RECOMMENDED FEEDER SIZE PER AMPERAGE

DOOR	FEEDER SIZE
200	10 AWG
220	10 AWG
240	10 AWG
260	10 AWG
280	10 AWG
300	10 AWG
320	10 AWG
340	10 AWG
360	10 AWG
380	10 AWG
400	10 AWG
420	10 AWG
440	10 AWG
460	10 AWG
480	10 AWG
500	10 AWG
520	10 AWG
540	10 AWG
560	10 AWG
580	10 AWG
600	10 AWG
620	10 AWG
640	10 AWG
660	10 AWG
680	10 AWG
700	10 AWG
720	10 AWG
740	10 AWG
760	10 AWG
780	10 AWG
800	10 AWG
820	10 AWG
840	10 AWG
860	10 AWG
880	10 AWG
900	10 AWG
920	10 AWG
940	10 AWG
960	10 AWG
980	10 AWG
1000	10 AWG

TABLE OF RECOMMENDED FEEDER SIZE PER AMPERAGE

DOOR	FEEDER SIZE
200	10 AWG
220	10 AWG
240	10 AWG
260	10 AWG
280	10 AWG
300	10 AWG
320	10 AWG
340	10 AWG
360	10 AWG
380	10 AWG
400	10 AWG
420	10 AWG
440	10 AWG
460	10 AWG
480	10 AWG
500	10 AWG
520	10 AWG
540	10 AWG
560	10 AWG
580	10 AWG
600	10 AWG
620	10 AWG
640	10 AWG
660	10 AWG
680	10 AWG
700	10 AWG
720	10 AWG
740	10 AWG
760	10 AWG
780	10 AWG
800	10 AWG
820	10 AWG
840	10 AWG
860	10 AWG
880	10 AWG
900	10 AWG
920	10 AWG
940	10 AWG
960	10 AWG
980	10 AWG
1000	10 AWG

TABLE OF RECOMMENDED FEEDER SIZE PER AMPERAGE

DOOR	FEEDER SIZE
200	10 AWG
220	10 AWG
240	10 AWG
260	10 AWG
280	10 AWG
300	10 AWG
320	10 AWG
340	10 AWG
360	10 AWG
380	10 AWG
400	10 AWG
420	10 AWG
440	10 AWG
460	10 AWG
480	10 AWG
500	10 AWG
520	10 AWG
540	10 AWG
560	10 AWG
580	10 AWG
600	10 AWG
620	10 AWG
640	10 AWG
660	10 AWG
680	10 AWG
700	10 AWG
720	10 AWG
740	10 AWG
760	10 AWG
780	10 AWG
800	10 AWG
820	10 AWG
840	

ACTIVATION WIRING

7822E011

1

3

NON-SEQUENTIAL 2 DOOR INTERLOCK

NON-SEQUENTIAL 3 DOOR INTERLOCK

NON-SEQUENTIAL 4 DOOR INTERLOCK

2

3

NON-SEQUENTIAL 2 DOOR INTERLOCK

NON-SEQUENTIAL 3 DOOR INTERLOCK

NON-SEQUENTIAL 4 DOOR INTERLOCK

2

4

NON-SEQUENTIAL 2 DOOR INTERLOCK

NON-SEQUENTIAL 3 DOOR INTERLOCK

NON-SEQUENTIAL 4 DOOR INTERLOCK

2

5

NON-SEQUENTIAL 2 DOOR INTERLOCK

NON-SEQUENTIAL 3 DOOR INTERLOCK

NON-SEQUENTIAL 4 DOOR INTERLOCK

2

6

NON-SEQUENTIAL 2 DOOR INTERLOCK

NON-SEQUENTIAL 3 DOOR INTERLOCK

NON-SEQUENTIAL 4 DOOR INTERLOCK

2

7

NON-SEQUENTIAL 2 DOOR INTERLOCK

NON-SEQUENTIAL 3 DOOR INTERLOCK

NON-SEQUENTIAL 4 DOOR INTERLOCK

2

8

NON-SEQUENTIAL 2 DOOR INTERLOCK

NON-SEQUENTIAL 3 DOOR INTERLOCK

NON-SEQUENTIAL 4 DOOR INTERLOCK

2

1

NON-SEQUENTIAL 2 DOOR INTERLOCK

NON-SEQUENTIAL 3 DOOR INTERLOCK

NON-SEQUENTIAL 4 DOOR INTERLOCK

1

2

NON-SEQUENTIAL 2 DOOR INTERLOCK

NON-SEQUENTIAL 3 DOOR INTERLOCK

NON-SEQUENTIAL 4 DOOR INTERLOCK

1

3

NON-SEQUENTIAL 2 DOOR INTERLOCK

NON-SEQUENTIAL 3 DOOR INTERLOCK

NON-SEQUENTIAL 4 DOOR INTERLOCK

1

4

NON-SEQUENTIAL 2 DOOR INTERLOCK

NON-SEQUENTIAL 3 DOOR INTERLOCK

NON-SEQUENTIAL 4 DOOR INTERLOCK

1

5

NON-SEQUENTIAL 2 DOOR INTERLOCK

NON-SEQUENTIAL 3 DOOR INTERLOCK

NON-SEQUENTIAL 4 DOOR INTERLOCK

1

6

NON-SEQUENTIAL 2 DOOR INTERLOCK

NON-SEQUENTIAL 3 DOOR INTERLOCK

NON-SEQUENTIAL 4 DOOR INTERLOCK

1

7

NON-SEQUENTIAL 2 DOOR INTERLOCK

NON-SEQUENTIAL 3 DOOR INTERLOCK

NON-SEQUENTIAL 4 DOOR INTERLOCK

1

8

NON-SEQUENTIAL 2 DOOR INTERLOCK

NON-SEQUENTIAL 3 DOOR INTERLOCK

NON-SEQUENTIAL 4 DOOR INTERLOCK

1

9

NON-SEQUENTIAL 2 DOOR INTERLOCK

NON-SEQUENTIAL 3 DOOR INTERLOCK

NON-SEQUENTIAL 4 DOOR INTERLOCK

1

10

NON-SEQUENTIAL 2 DOOR INTERLOCK

NON-SEQUENTIAL 3 DOOR INTERLOCK

NON-SEQUENTIAL 4 DOOR INTERLOCK

1

11

NON-SEQUENTIAL 2 DOOR INTERLOCK

NON-SEQUENTIAL 3 DOOR INTERLOCK

NON-SEQUENTIAL 4 DOOR INTERLOCK

1

12

NON-SEQUENTIAL 2 DOOR INTERLOCK

NON-SEQUENTIAL 3 DOOR INTERLOCK

NON-SEQUENTIAL 4 DOOR INTERLOCK

1

13

NON-SEQUENTIAL 2 DOOR INTERLOCK

NON-SEQUENTIAL 3 DOOR INTERLOCK

NON-SEQUENTIAL 4 DOOR INTERLOCK

1

14

NON-SEQUENTIAL 2 DOOR INTERLOCK

NON-SEQUENTIAL 3 DOOR INTERLOCK

NON-SEQUENTIAL 4 DOOR INTERLOCK

1

15

NON-SEQUENTIAL 2 DOOR INTERLOCK

NON-SEQUENTIAL 3 DOOR INTERLOCK

NON-SEQUENTIAL 4 DOOR INTERLOCK

1

16

NON-SEQUENTIAL 2 DOOR INTERLOCK

NON-SEQUENTIAL 3 DOOR INTERLOCK

NON-SEQUENTIAL 4 DOOR INTERLOCK

1

17

NON-SEQUENTIAL 2 DOOR INTERLOCK

NON-SEQUENTIAL 3 DOOR INTERLOCK

NON-SEQUENTIAL 4 DOOR INTERLOCK

1

18

NON-SEQUENTIAL 2 DOOR INTERLOCK

NON-SEQUENTIAL 3 DOOR INTERLOCK

NON-SEQUENTIAL 4 DOOR INTERLOCK

1

19

NON-SEQUENTIAL 2 DOOR INTERLOCK

NON-SEQUENTIAL 3 DOOR INTERLOCK

NON-SEQUENTIAL 4 DOOR INTERLOCK

1

20

NON-SEQUENTIAL 2 DOOR INTERLOCK

NON-SEQUENTIAL 3 DOOR INTERLOCK

NON-SEQUENTIAL 4 DOOR INTERLOCK

1

21

NON-SEQUENTIAL 2 DOOR INTERLOCK

NON-SEQUENTIAL 3 DOOR INTERLOCK

NON-SEQUENTIAL 4 DOOR INTERLOCK

1

22

NON-SEQUENTIAL 2 DOOR INTERLOCK

NON-SEQUENTIAL 3 DOOR INTERLOCK

NON-SEQUENTIAL 4 DOOR INTERLOCK

VIRTUAL VISION ELECTRICAL DRAWING

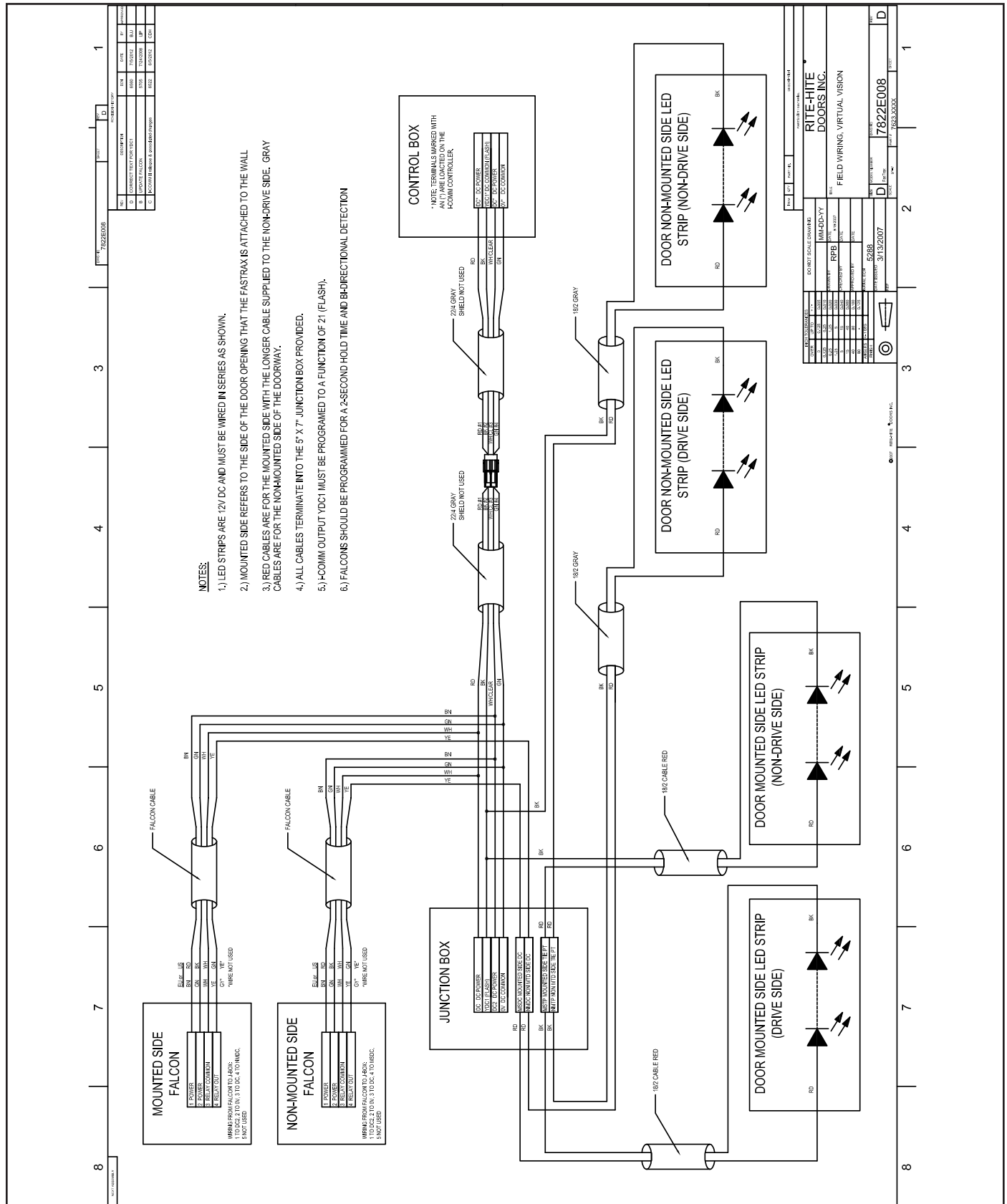

ELECTRICAL DRAWING DUAL BLOWER 220/400V

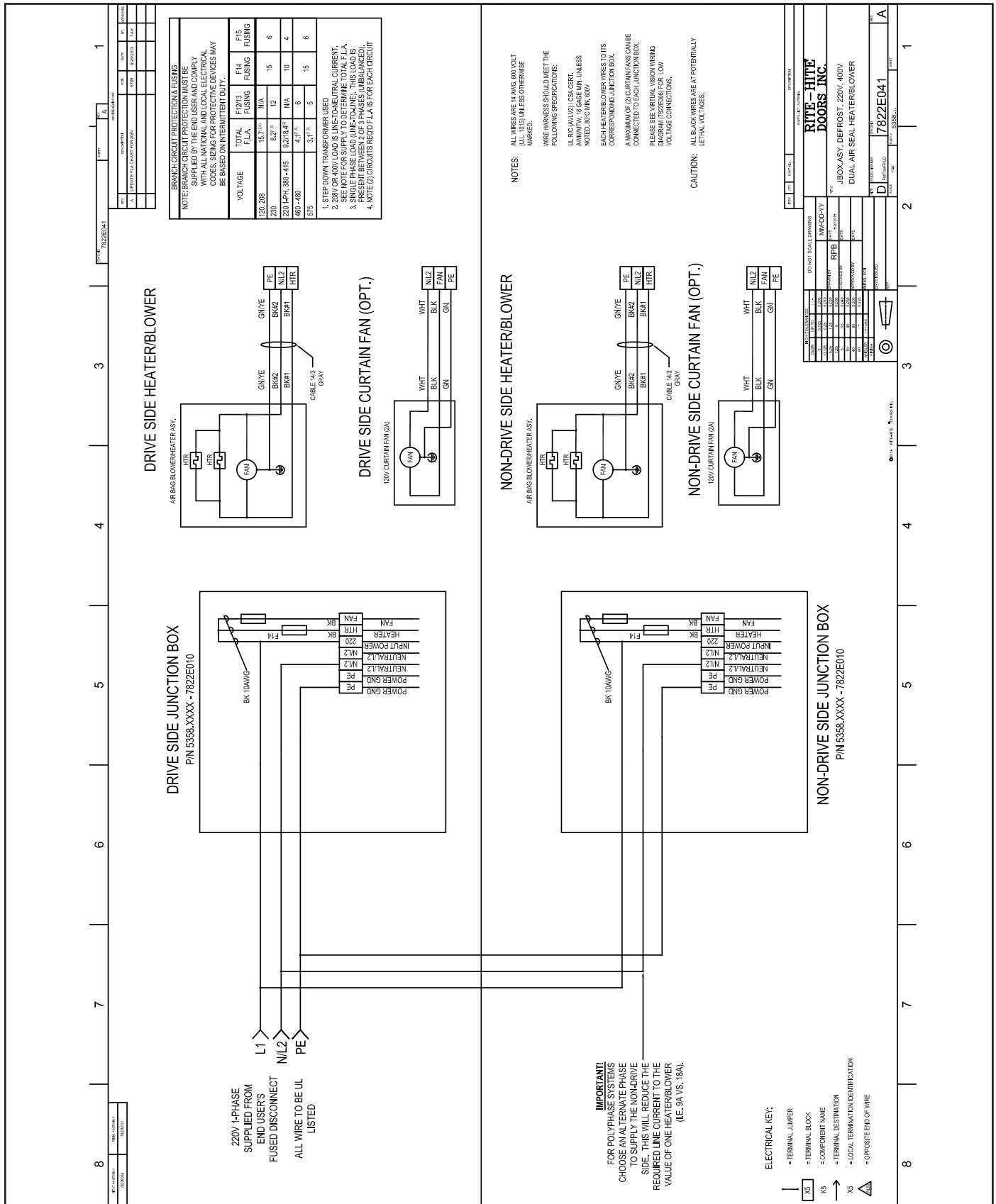

CHAPTER 10

CONTROL BOX SERVICE PARTS

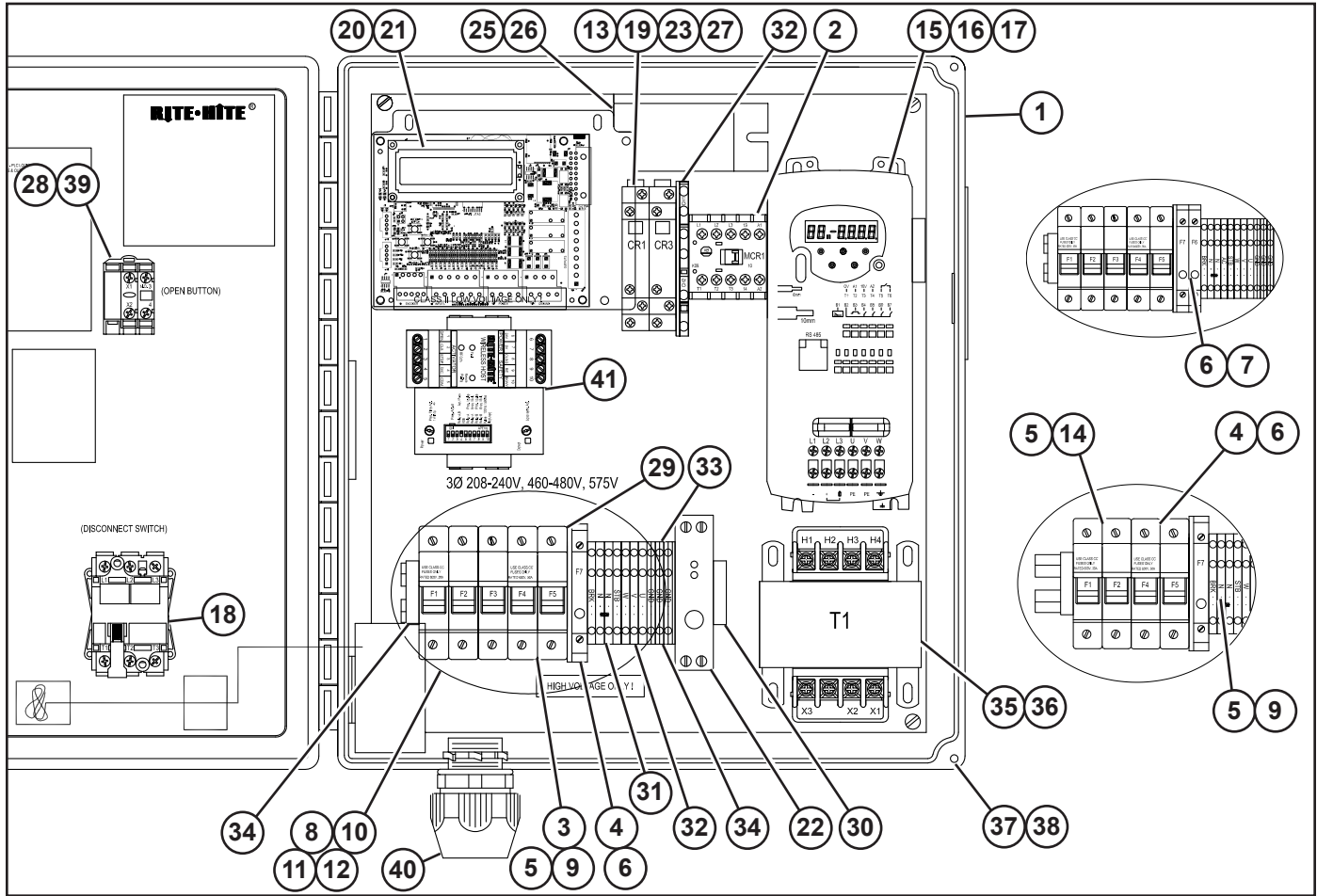

ITEM	QTY	DESCRIPTION	P/N
1	1	Ass'y (C-Box, Back-panel, Enclosure w/labels)	1753....
2	1	Contactors 24VDC,9A, 4NO (Chain hoist)	17000028
3	2	Fuse, 0.5 amp, 600V Time Delay (400-575V)	51000001
4	1	Fuse, 1 amp, 250V Time Delay	51000002
5	1/2	Fuse Holder, 2 Pole, 600V, 30A (3Ø-1; 1Ø-2)	51000003
6	2	Fuse Holder, 1 Pole, 300V, 12A	51000004
7	1	Fuse, 2 amp, 250V, Time Delay (FR only)	51000005
8	1	Fuse Holder, 3 Pole, 600V, 30A (not 220V 1Ø)	51000013
9	2	Fuse, 1 amp, 600V, CC, Time Delay (208-230V)	51000023
10	3	Fuse, 10 amp, 600V, CC, KLDR (400-460V)	51000033
11	3	Fuse, 15 amp, 600V, KLDR (208-230V)	51000051
12	3	Fuse, 6A, 600V, CC, KLDR (575V)	51000055
13	1	Kit, Warning Device Relay, i-COMM (#23,#27, wire)	53700862
14	2	Fuse, 20 amp, 600V, KLDR (220V 1Ø)	51950077
15	1	Inverter, 2HP, 575V, 3PH, AB-FLEX40 (575V)	53300044
16	1	Inverter, 2HP, 460V, 3PH, CT (460V)	53300047
17	1	Inverter, 2HP, 230V, 1-3PH, CT (208-230V)	53300046
18	1	Kit, Disconnect Switch, w/ Handle	53700567
19	1	Kit, Relay (includes #23, #27 & wire)	53700643
20	1	Kit, i-COMM ii, Replacement	53700860
21	1	Kit, i-COMM ii, Upgrade (< 6/20/2012)	7302....
22	1	Power Supply, DIN, 24VDC, 18W (<=22W)	65700006
22	1	Power Supply, DIN, 24VDC, 30W, CG (>22W)	65700007

ITEM	QTY	DESCRIPTION	P/N
23	1/1	Relay, SPDT,24VDC,10AMP (warn device & brake)	66450014
24	1	Relay, SPDT, 24VAC/DC, 6 Amp, Term (upgrade) Not shown (for doors <8/5/09)	66450033
25	1	Kit, Resistor, Inverter, 230V, 2HP	53700689
26	1/1	Kit, Resistor, Inverter, 460V, 2HP	53700688
27	1	Socket, Relay,1Pole,250VAC,10AMP (W.D. & Brake)	70350002
28	1	Switch, Push Button, Ext, Green, Illum, 22MM => 6/20/2012	72700258
29	1	Terminal, End Barrier, Fuse Holder	73100019
30	4/6	Terminal, End Stop, Screwless	73100024
31	1	Terminal, WA, Cage, 20A, Jump, 2P	73100081
32	7/8	Terminal, WA, Cage, 20A, 3 Hole	73100085
33	2	Terminal, WA, Cage, 20A, 3 Hole, Barrier	73100086
34	3	Terminal, WA, Cage, 20A, 3 Hole, GND	73100087
35	1	Transformer, 100VA, 208/230/460V:24/115	73550029
36	1	Transformer, 100VA, 380/415/575V:24/115	73550030
37	2	Control Box Quick Release Latch	51950021
38	4	Control Box Mounting Tab	51950018
39	1	Switch, Push Button, Ext, Green, Illum, 22MM (< 6/20/2012)	72700005
40	1	Connector, Conduit, Straight, L/T, 1"	16960001
41	1	Controller, Ind Loop, Dual, 12/24V	17500010
42	1	Cable, Inverter, 24/4 UTP (Modbus)	15650290

Dwg # 7822E030 Rev. J

Note: 39 and 42 are not shown.

DRIVE SYSTEM SERVICE PARTS

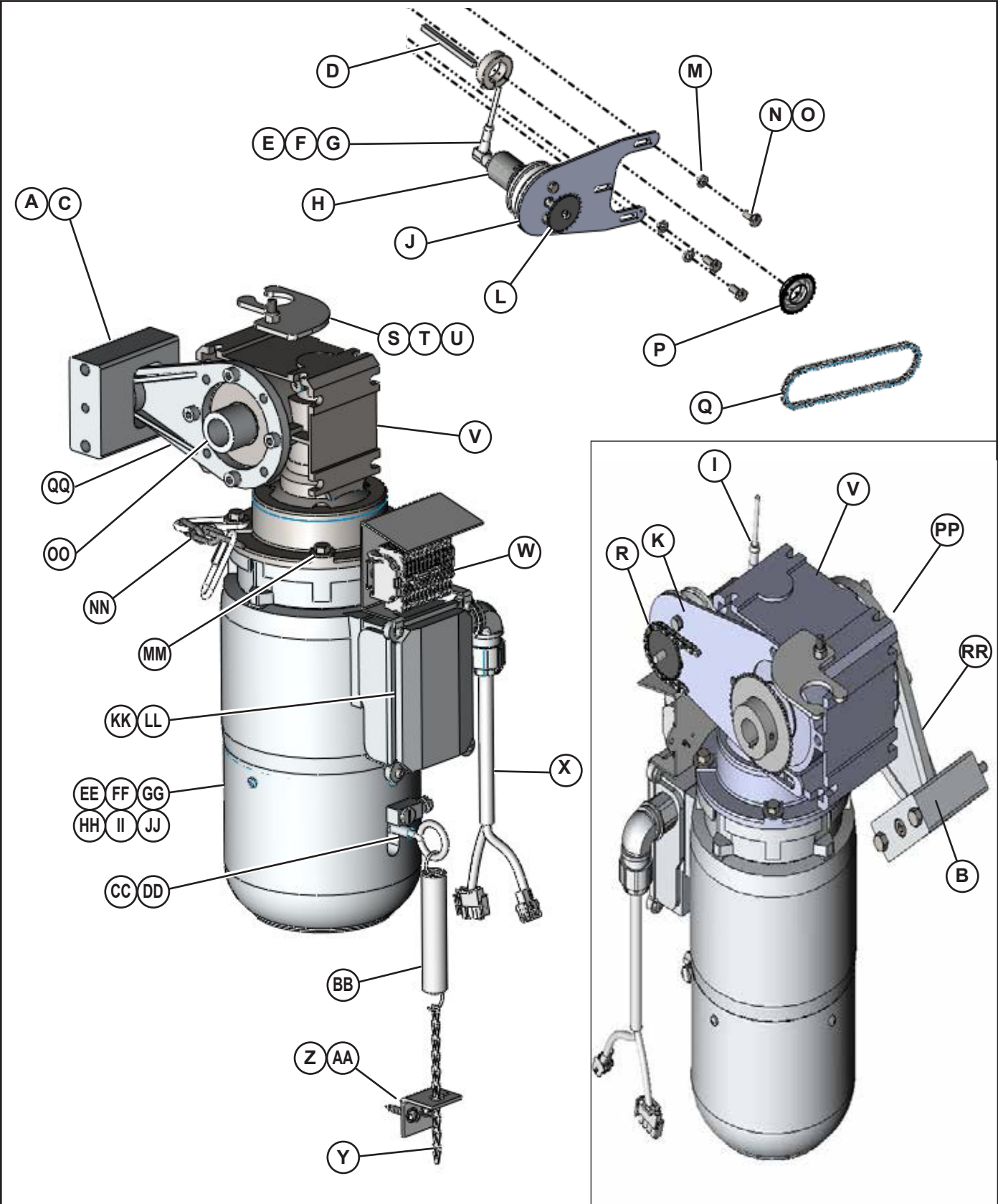

FASTRAX® FR LD

A	Block, Mount, Nord, #50	1	13000060
B	Block, Mount, Nord, #63	1	13000065
C	Screw, SHCS, M10-1.5 x 80MM	1	67930032
D	Gearbox Key	1	53550010
E	Encoder Cable 4M	1	15650256
F	Encoder Cable 8M	1	15650257
G	Encoder Cable 17M	1	15650258
H	Encoder Kit, #50	1	53700784
I	Encoder Kit, #63	1	53700878
J	Encoder Plate, #50	1	65000724
K	Encoder Plate, #63	1	65000805
L	Sprocket Driven	1	70800048
M	Lock Washer	3	74120002
N	M8-1.25x16MM (10:1, 15:1 GBX)	3	67930016
O	M10-1.50x20MM (20:1 GBX)	3	67930036
P	Sprocket Drive	1	70800064
Q	Encoder Chain, #50	1	16600065
R	Encoder Chain, #63	1	16600067
S	Conduit Bracket	1	14501096
T	Nut, Hex, Lock, 5/16-18, znc	1	55620010
U	Screw, HHMS, 5/16-18x1 1/4", GR5, znc	1	67870003
V	Gearbox (See Gearbox Ratios table)	—	—
W	Terminal Assembly	1	73100093
X	Motor Cable	1	15650245
Nord Optional Brake Release			
Y	Sash Chain (14")	1	16660046
Z	Hold Down Bracket	1	14500981
AA	Screw, HWHSMS, #14x1 1/4", znc	1	67850001
BB	Ext. Spring	1	70700021
CC	Nut, Hex, 6M-1	1	55680001
DD	Bolt, Eye, 6Mx30MM, znc	1	67930001
EE	Motor/Brake/Gearbox Ass'y	1	5540....
FF	Motor/Brake,2HP, 230/460V	1	55250138
GG	Motor/Brake,2HP, 575V	1	55250139
HH	Motor/Brake,2HP, 400V	1	55250143
II	Motor/Brake,1.5HP, 230/460V	1	55250213
JJ	Motor/Brake,1.5HP, 400V	1	55250214
KK	Brake Rectifier 230/460V	1	66270009
LL	Brake Rectifier 575V	1	66270012
MM	Washer, Flat, 5/16, znc	4	74120003
NN	Chain Kit	1	53700650
OO	Spacer, Gearbox Nord, #50	1	70450167
PP	Spacer, Gearbox Nord, #63	1	70450168
QQ	Torque Arm, Gearbox, #50	1	11500049
RR	Torque Arm, Gearbox, #63	1	11500083
—	NOT SHOWN: Aero Lubriplate	1	54650001

Gearbox Ratios - Non-Canadian & 575V			
Ratio	GBX p/n	MTR p/n	Insulated Curtain
10:1 (Sz 50)	51250028	55250138, 139, 143	Doors < 112 SF
15:1 (Sz 50)	51250014	55250213, 214	Doors >= 112 SF & <= 160 SF
15:1 (Sz 63)	51250033	55250138, 139, 143	Doors > 160 SF
Gearbox Ratios - Canadian & 575V			
Ratio	GBX p/n	MTR p/n	Insulated Curtain
10:1 (Sz 50)	51250028	55250138, 139, 143	Doors < 112 SF
15:1 (Sz 63)	51250033	55250138, 139, 143	Doors >= 112 SF

MISC SERVICE PARTS

FSTXFRLD Entire Door	1	FSTXFRLD
Kit, FasTrax Service Parts, US, Encoder	1	53700804
Kit, FasTrax Service Parts, Int, Encoder	1	53700806
FasTrax Sample	1	67750026
Crate	1	53700146

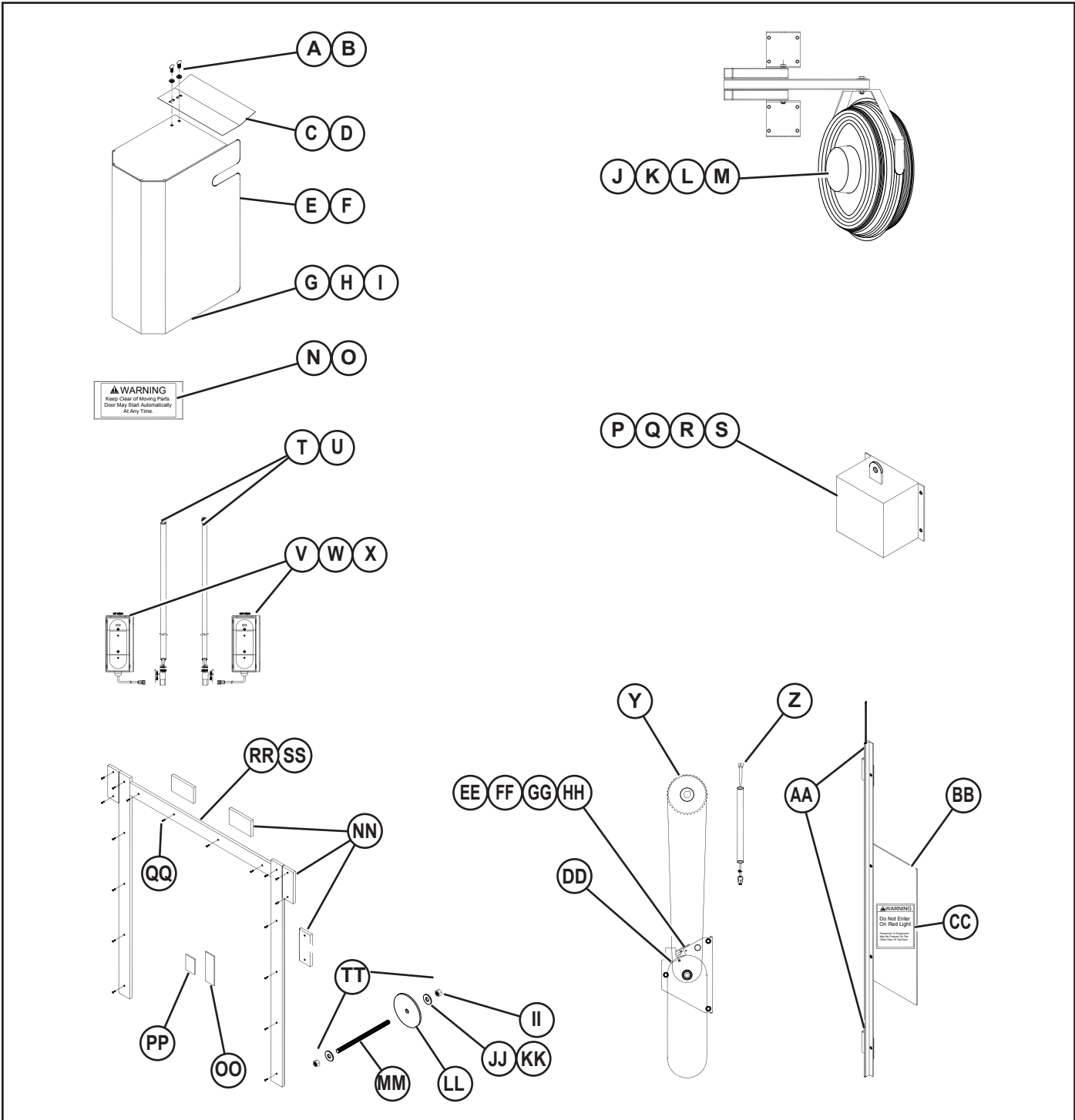

FASTRAX® FR LD

A	H18	4	—
B	H30	4	—
C	LH Shroud Extension Plate	1	65000627
D	RH Shroud Extension Plate	1	65000628
E	RH Drive Shroud	1	53700600 (Includes Hardware & Extension Bracket)
F	LH Drive Shroud		
G	Conn, Pipe, ABS, 1 1/2", Male	1	16960090
H	Conn, Pipe, ABS, 1 1/2", Female	1	16960091
I	Plug, Plastic, 2 3/16"	1	65300023
J	120V Curtain Fan Kit	2	53700769
K	120V Fan only	2	13250069
L	120V Arm only	2	11500046
M	220V Curtain Fan Kit	2	53700770
N	Keep Clear Warning Label	1	53850534
O	Sign Plate (Doors <8'-0" H w/o Shroud)	1	65000609
P	Transformer, 2KVA, 600:240/120	1	73550017
Q	Transformer, 2KVA, 480/240:240/120	1	73550024
R	Transformer, 3KVA, 600:240/120 (CE only)	1	73550026
S	Transformer, 3KVA, 480/240:240/120 (CE only)	1	73550027
T	I-Zone Cable, Non-Drive	1	1549....
U	I-Zone Cable, Drive	1	1550....
V	I-Zone Detector Assembly	2	7622....
W	I-Zone Upgrade	a/r	7637....
X	I-Zone Cover	2	17900111
Y	Sprocket, #41, 70T, 1" Bore, Steel	1	70800066
Z	Chain Hoist Cable	1	15650234
AA	Virtual Vision Mounting Bracket	8	14500971
	H1	2	—
	H14	2	—
BB	Virtual Vision LED Assembly	4	7623....
CC	Virtual Vision Warning Plate	4	65000586
	H1	2	—
	H10	2	—
DD	Chain Hoist Switch, Interior	1	72700218
EE	Chain Hoist,4:1 Ratio	1	56150038
FF	Chain Hoist, Shroud, Interior	1	53700796
GG	Kit, FSTX FR LD, Chain Hoist, Interior i-COMM i (=<6/20/12)	1	53700880
HH	Kit, FSTX FR LD, Chain Hoist, Interior i-COMM ii (=>6/20/12)	1	53700897
II	H6	24	—
JJ	H28	24	—
KK	H35	24	—
LL	Plate, 6" Ø, znc	12	65000723
MM	H26	12	—
NN	Poly Lumber Header Shim	5	69000015
OO	Upper Track Weld Plate	6	65000588
PP	Lower Track Weld Plate	16	65000587
QQ	H7	a/r	—

RR	Poly Lumber Install Kit	1	5339....
SS	Poly Lumber 1 1/2"x7 1/2"x10'-6"	a/r	65450100
TT	Kit, Install, Thru-Wall, Steel	a/r	53700887

CURTAIN SERVICE PARTS

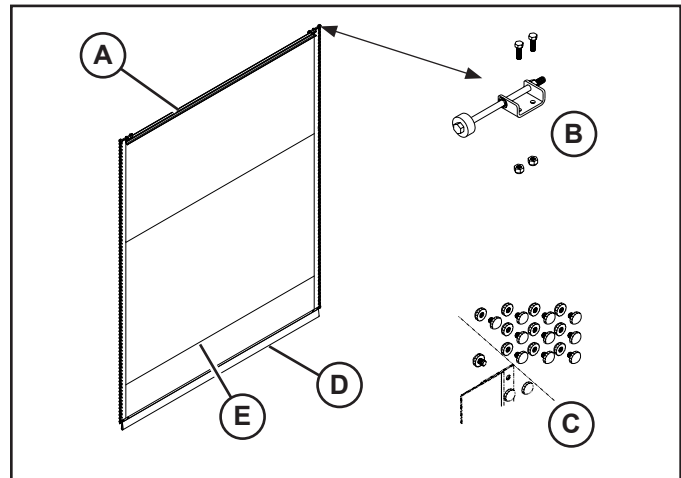

A	Curtain, Stiffener	1	7181....
B	Kit, Curtain Top Roller (includes 2)	1	53700562
C	Curtain, Kit, Drive Sphere, Qty 10	a/r	53700561
D	Curtain, Insulated, Bottom Loop	1	6895....
E	Curtain, Assembly, FasTrax, Insulated	1	2877....
PATCH KIT PARTS LIST			
	Curtain, Patch Kit, Urethane, 27 oz, Blue (FR)	a/r	53700774

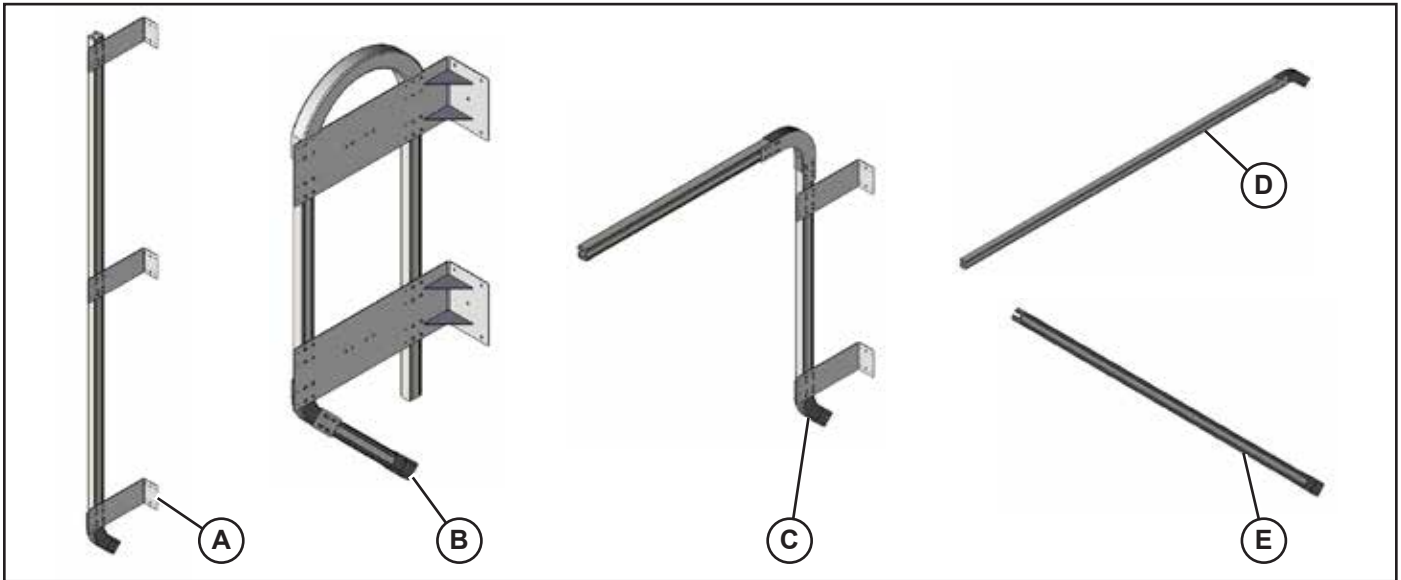

	Upper Track, Wrap Back VL, High, Stand, Tilt	1/2	7382....
A	Vertical Lift		
B	Wrap Back		
C	High Lift		
D	Standard Lift		
E	Tilt Lift		

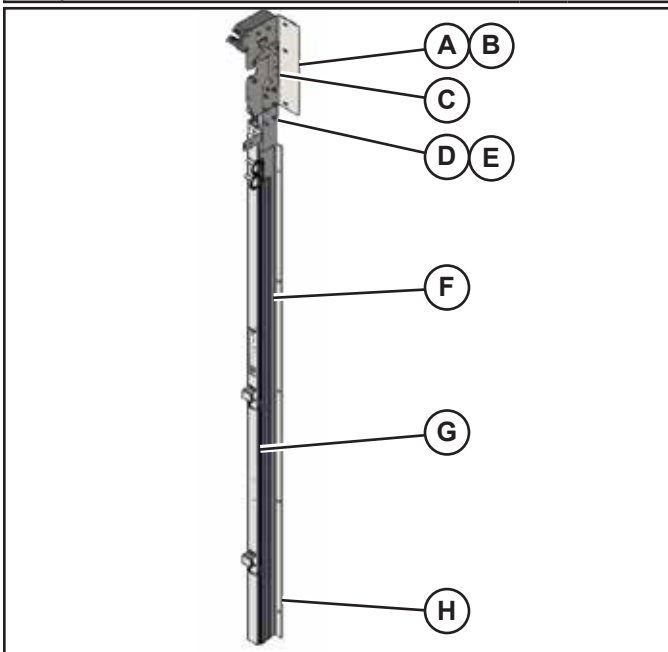
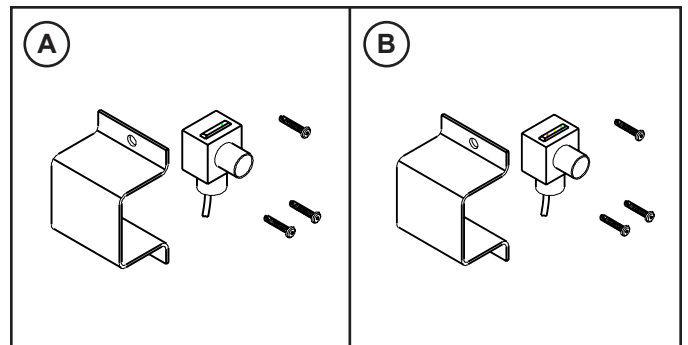

Non-Drive Side (A)		
Kit, Photoeye, Thru-beam Source, 13M	2	53700702
Photoeye, Bracket Cover	4	14501207
Drive Side (B)		
Kit, Photoeye, Thru-beam Receiver	2	53700703
Photoeye, Bracket Cover	4	14501207

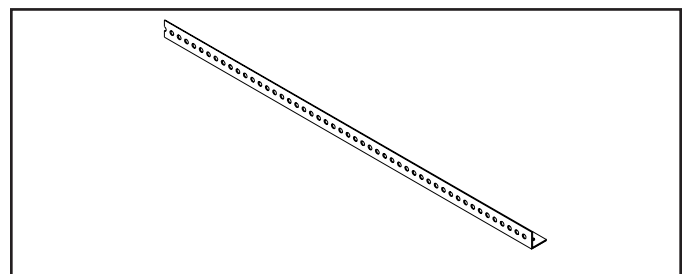

Track, Perforated, Angle, 2"x2"x13', 12GA	13'	71500030
---	-----	----------

A	Bracket, Header, FR LD, RH	1	14501272
B	Bracket, Header, FR LD, LH	1	14501273
C	H24	—	—
D	H5	—	—
E	H23	—	—
F	Photoeye, Wiring Cover	2	1917....
G	Super Lube	a/r	54650002
H	Lower Track Assembly	a/r	7381....

FASTRAX® FR LD

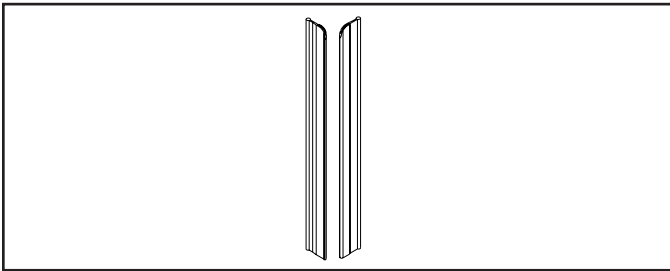

Breakaway Retention Strips	a/r	1481....
----------------------------	-----	----------



Bracket, Shroud, Lower	1	14501275
------------------------	---	----------

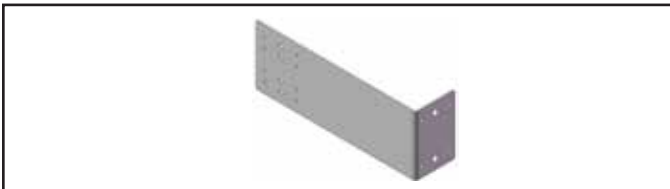

Bracket, Wall, Mount, FasTrax FR LD	4	14501276
-------------------------------------	---	----------

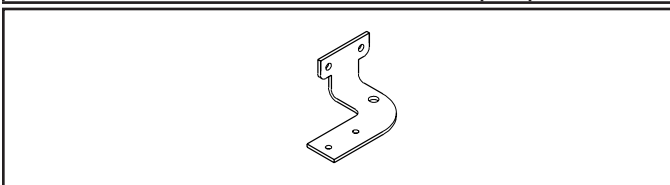

Shroud, Bracket, Upper, LH	1	14501097
----------------------------	---	----------

Shroud, Bracket, Upper, RH	1	14501099
----------------------------	---	----------

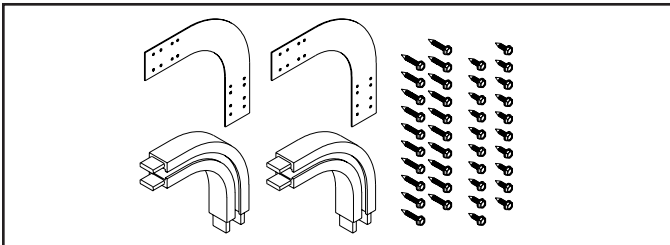

Kit, Track Connector, Radius, 90°	1	53600185
-----------------------------------	---	----------

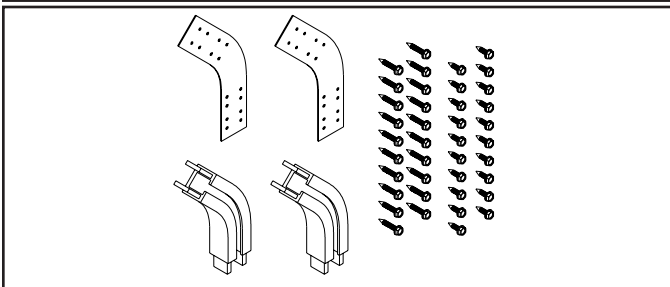

Track, Kit, Connector, Radius, 45°	1	53600189
------------------------------------	---	----------

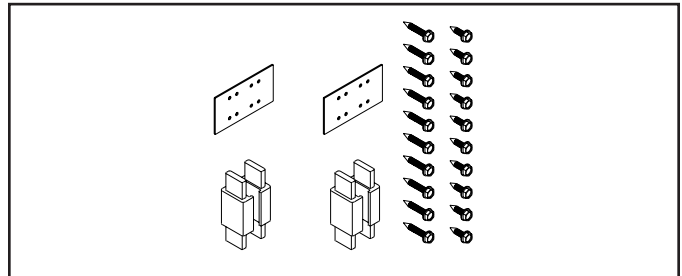

Kit, Universal Track Connector	a/r	53600186
--------------------------------	-----	----------

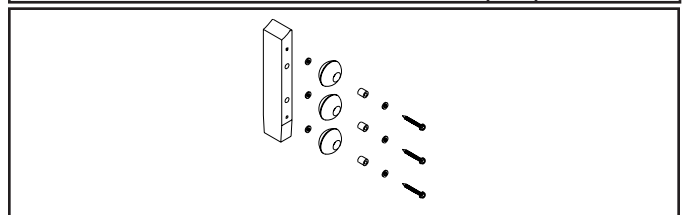

Kit, FasTrax, Refeed, LH (bracket & 3 rollers)	1	53700606
--	---	----------

Kit, FasTrax, Refeed, RH (bracket & 3 rollers)	1	53700607
--	---	----------

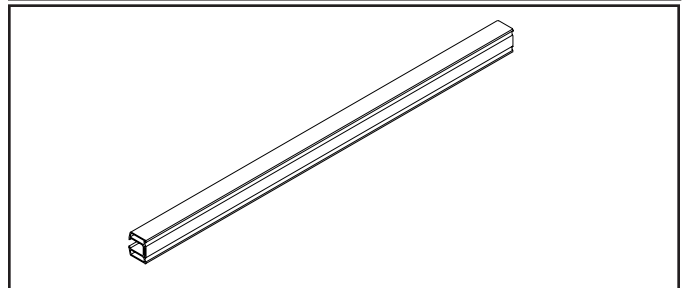

Track, Upper, = < 10'-0" O.D.H.	2	53700627
---------------------------------	---	----------

Track, Upper, = < 12'-0" O.D.H.	2	53700628
---------------------------------	---	----------

Track, Upper, = < 14'-0" O.D.H.	2	53700629
---------------------------------	---	----------

Track, Upper, = < 16'-0" O.D.H.	2	53700630
---------------------------------	---	----------

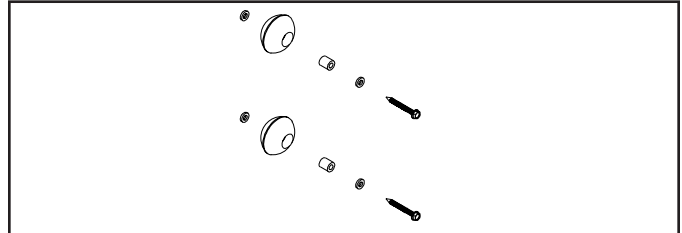

Kit, FasTrax/FR, Refeed Roller (2)	a/r	53700611
------------------------------------	-----	----------

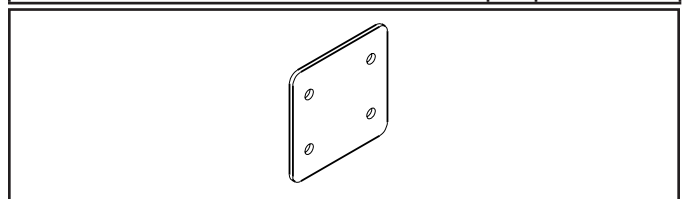

Track, Joiner, Drive Cage	2	65000576
---------------------------	---	----------

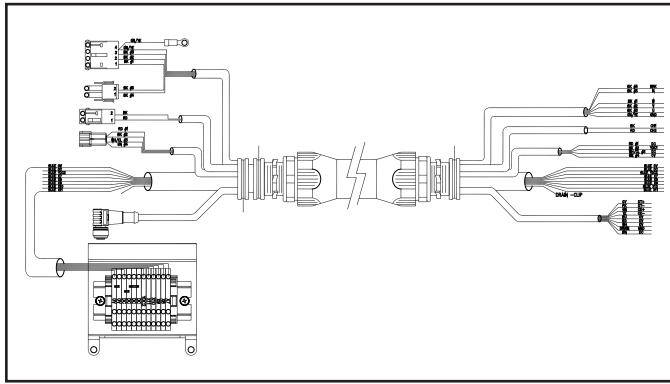

Control Box Cable Assembly (Specify length: 10'-30')	1	1555....
---	---	----------

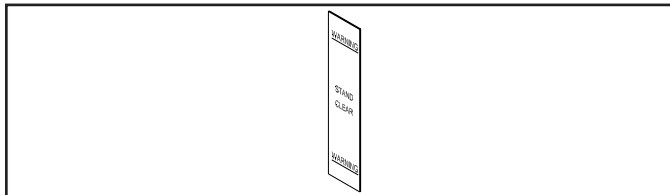

Label, Warning, Stand Clear, 2" x 9"	2	53850516
--------------------------------------	---	----------

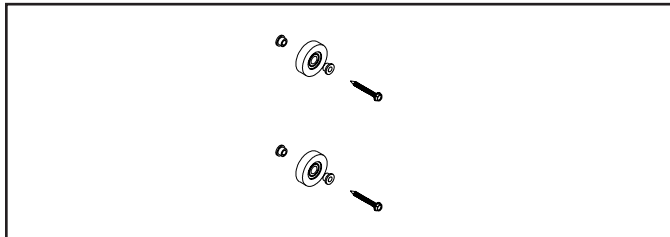

Kit, Radial Nylon Roller	2	53700632
--------------------------	---	----------

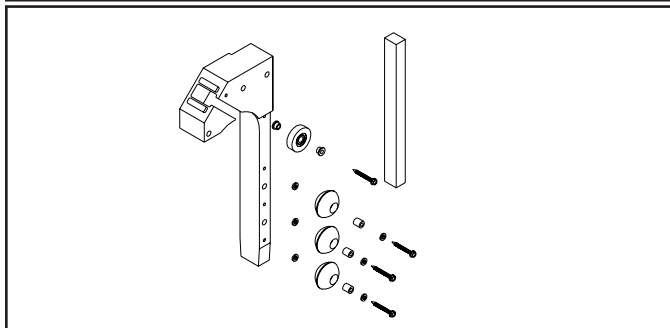

Kit, Bracket, Drive Cage, Non Radial, L	1	53700645
---	---	----------

Kit, Bracket, Drive Cage, Non Radial, R	1	53700646
---	---	----------



Guard, Drive Non-Radial (2 - <8' d.o.h.)	2	51300068
--	---	----------

WRAP BACK & HARDWARE SERVICE PARTS

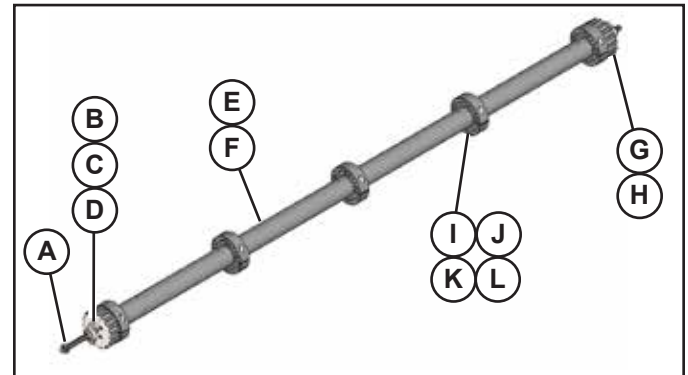

A	Collar, Shaft, Lock, 1" Ø	2	16850018
B	Bearing, Flange, 1" Bore	2	12500034
C	H25	—	—
D	H50	—	—
E	FasTrax FR LD Drive Tube, Ass'y	1	6756....
F	FasTrax FR LD Drive Tube, Weld (Does not include Collars)	1	6757....
G	FasTrax FR LD Sprocket	2	70800061
H	Nut, Hex, Nyl, Lock, 3/8-16, znc	8	55630005
I	FasTrax FR LD Drive Tube Collar	10	16850025
J	Nut, Hex, Nyl, Lock, 1/4-20, znc	10	55610001
K	Screw, HHMS, 1/4-20x1 3/4, GR5, znc	10	67860062
L	Washer, Flat, .281 x .62 x .125	20	74120012

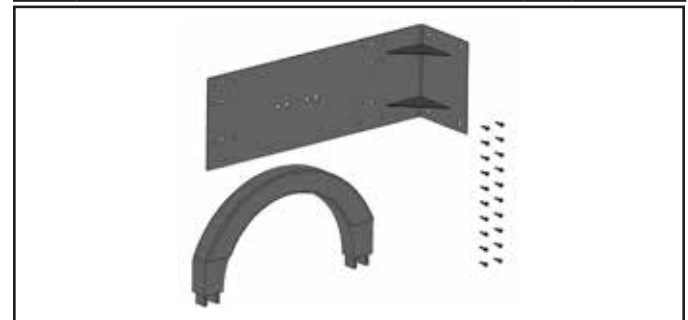

A	Kit, Wrap Back, 180°	2	53600205
B	H9	—	—
C	H38	—	—

FASTRAX® FR LD

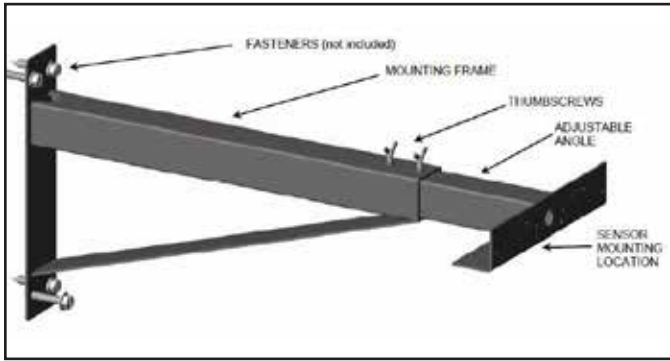

Bracket, BEA Falcon	a/r	14501212
---------------------	-----	----------

Hardware List

#	Hardware List	Part #
H1	Nut, Hex, Nylon, Lock, #10-24, zinc	55600004
H2	Nut, Hex, Nylon, Lock, 1/4-20, znc	55610001
H3	Nut, Hex, Nylon, Lock, 5/16-18, znc	55620010
H4	Nut, Hex, 3/8-16, znc	55630003
H5	Nut, Hex, Nylon, Lock, 3/8-16, znc	55630005
H6	Nut, Hex, 3/8-16, S.S.	55630006
H7	Rivet, Blind, Fablok, 5/16" x 1.807	66840016
H8	Ring, Retaining, External, 5/16" Shaft	67020051
H9	Screw, HWHMS, #14 x 1 1/4", znc	67850001
H10	Screw, RHMS, Phillips, #10-24 x 1/2", zinc	67850008
H11	Screw, Phlp, Dr/Tap, #8 x 1/2"	67850015
H12	Screw,PHSMS,Phillips,Tap,#8-18x3/4"	67850026
H13	Screw, PHSMS, Phillips, #10 x 1", znc	67850029
H14	Screw, RHMS, Phillips, #10-24 x 3/4", zinc	67850030
H15	Screw,FHWH,#8x9/16",BLK,K-LATH	67850065
H16	Screw,PH,Phillips,Plstite,#8-16x3/8"	67850088
H17	Screw, Phillips, Drill/Tap, #8 x 1/2"	67850115
H18	Screw, Thumb, 1/4-20 x 1/2", GR2 znc	64860019
H19	Screw, HWH, Drill/Tap, #14x3/4", znc	67860094
H20	Screw, HHMS, 5/16-18x6", GR5, znc	67870111
H21	Screw, HHMS, 3/8-16 x 1", GR5, znc	67880002
H22	Screw, HHMS, 3/8-16x1 1/4",GR5,znc	67880004
H23	Screw, HHMS, 3/8-16 x 3 1/2", znc	67880017
H24	Screw, HHMS, 3/8-16 x 4", GR5, znc	67880029
H25	Screw, HHMS, 1/2-1 x 1", GR5, znc	67900003
H26	Rod, Threaded, 3/8-16 x 12" S.S.	67900047
H27	Tape, Foam, Double Sided	72800044
H28	Washer, Flat, 3/8" x 1" x .063, S.S.	74130012
H29	Washer, Flat, 1/4 x 3/4 x 1/16, znc	74110001
H30	Washer,Flat,1/4x9/16"x3/32",Neoprene	74110007
H31	Washer, Lock, Split, 3/8", znc	74130002
H32	Washer, Lock, Split, 1/2", znc	74150005
H33	Screw, Self Tap/Drill #12	67850004
H34	Washer, Flat, .39 x .75 x .062, Nylon	74130003

#	Hardware List	Part #
H35	Washer, lock, 3/8", S.S.	74130009
H36	Clamp, Cable, Nylon, 3/16"	16700009
H37	Washer, Lock, Int/Ext, #10, znc	74100004
H38	Screw, HWH, Drill/Tap, #14x 1 1/4", znc	67860001
H39	Screw, RHMS, PHLP, #10-24 x 3/8", znc	67850052
H40	Screw, HHMS, 3/8-16x4", Nyl Patch	67880140
H41	Screw, HHMS, 3/8-16x4 1/2", Nylon Patch	67880141
H42	Screw, HHMS, M8, 1.25x16MM, GR8	67930016
H43	Screw, HHMS, M10, 1.50x20MM, CL10.9	67930036
H44	Tie, Cable, Plastic, 7.94"	73250001
H45	Tie, Cable, Plastic, 4", 18#	73250004
H46	Tie, Cable, Plastic, 17"	73250006
H47	Washer, Lock, Split, 5/16", znc	74120002
H48	Washer, Flat, 3/8x1x.063,znc	74130001
H49	Tape, Foam, Double Sided, .062x1"	72800040
H50	Washer, Lock, Ext, 1/2", znc	74150019

AIR SEAL & WRAP BACK SERVICE PARTS

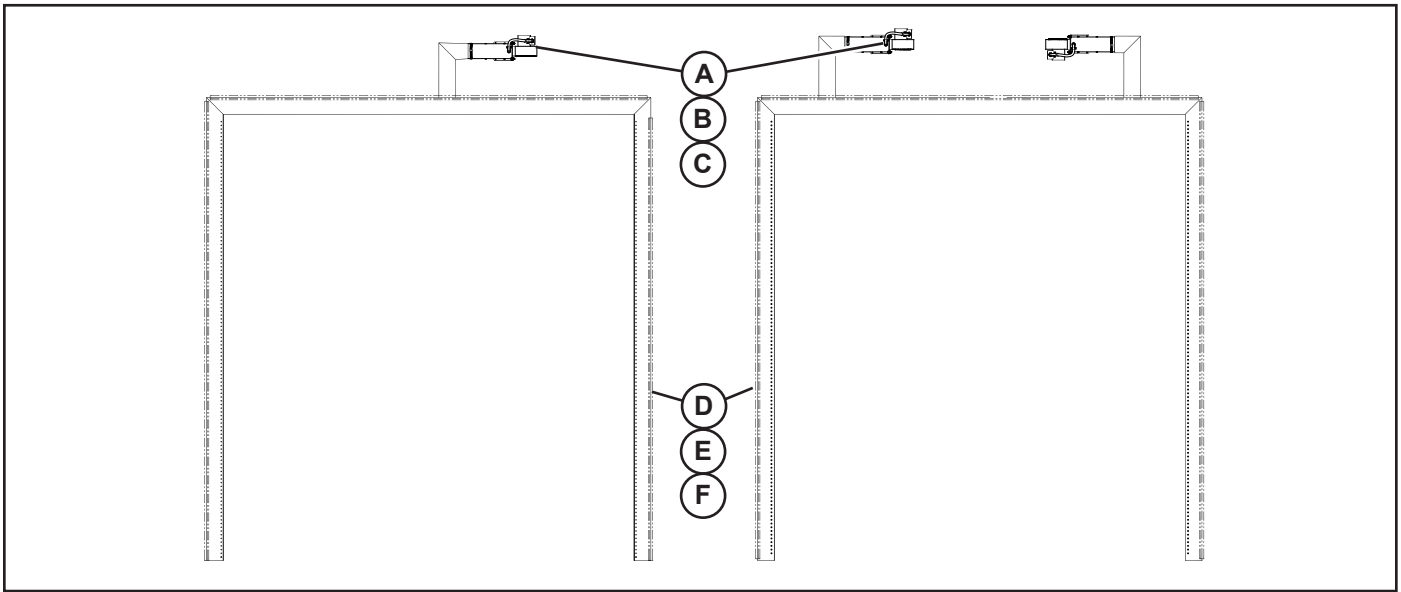

A	Air Seal Blower/Heater Kit, PTC, 10V	1/2	53700760
B	Air Seal Blower/Heater Kit, PTC, 230V	1/2	53700761
C	Air Seal Blower/Heater Kit, (Canada)	1/2	53700783
D	Thermal Air System Seal	1	6889....
E	Trailer Rail, 45° Alum	a/r	73400002
F	H11	—	—

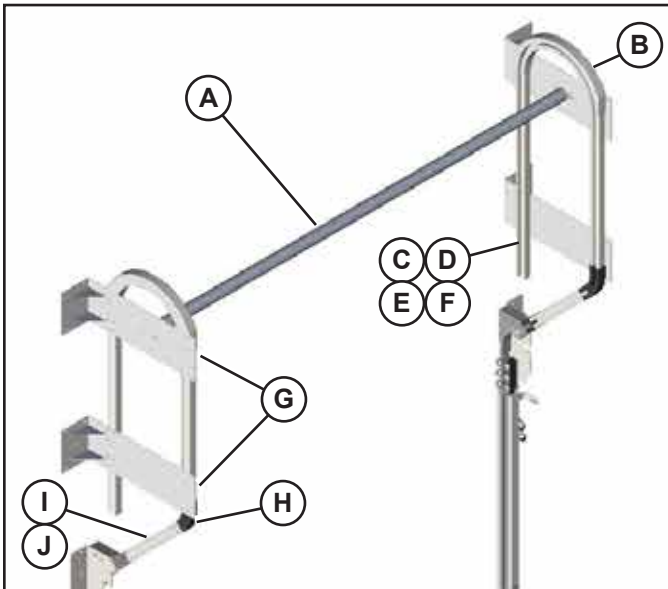

	Upper Track, Wrap Back, FasTrax FR LD	1	7382....
A	Spreader Bar, Wrap Back, FasTrax/FR/LD	1	7258....
B	Connector, 180°, Wrap Back, FasTrax	2	16950032
C	Track, Upper, =< 10'-0" O.D.H.	2	53700627
D	Track, Upper, =< 12'-0" O.D.H.	2	53700628
E	Track, Upper, =< 14'-0" O.D.H.	2	53700629
F	Track, Upper, =< 16'-0" O.D.H.	2	53700630
G	Bracket, Upper Track, Wrap Back, FasTrax	4	14501277
H	Kit, Track, Connector, Radius, 45°	1	53650189
I	Kit, Universal Track Connector	a/r	53600186
J	Connector, Radius, Univ°	2	16950074

JUNCTION BOX SERVICE PARTS

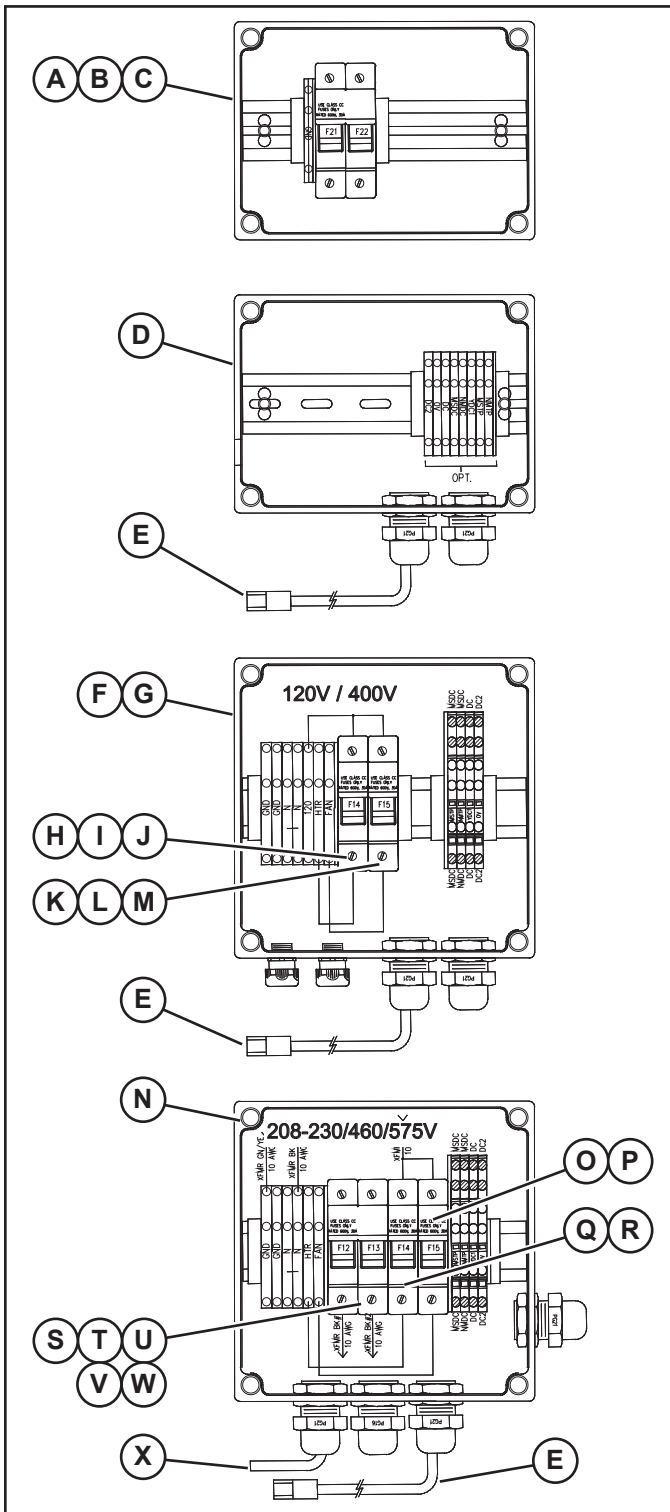

A	Curtain Fan Only Junction Box, FasTrax	1	53530012
B	2 Pole Fuse Holder, 600V, 30A	1	51000003
C	Fuse, 3AMP, 600V, Time Delay	1	51000008
D	Virtual Vision Only Junction Box Ass'y FasTrax CE Option only	1	5357....
E	Cable, Virtual Vision	1	15650233
F	Junction Box Ass'y FasTrax CE Option only	1	5357....
G	Junction Box Ass'y FasTrax FR	1	5358....
120V:			
H	Fuse Holder, 2 Pole, 600V, 30A (208, 230, 460, 480, 575V)	1	51000003
I	Fuse, 10A, 600V, CC, Time Delay (400V)	1	51000011
J	Fuse, 6A, 600V, CC, KLDR (2-460-480V or 1-120V)	1	51000055
400V:			
K	Fuse, 10A, 600V, CC, Time Delay (400V)	1	51000011
L	Fuse Holder, 1 Pole, 600V, 30A (208, 230, 460, 480, 575V)	2	51000019
M	Fuse, 4A, 600V, CC, Time Delay (400V)	1	51000040
N	Junction Box Ass'y FasTrax FR	1	5358....
208-460V:			
O	Fuse Holder, 1 Pole, 600V, 30A	2	51000019
P	Fuse, 6A, 600V, CC, KLDR (2-460-480V or 1-120V)	2	51000055
208-460V			
Q	Fuse Holder, 1 Pole, 600V, 30A	2	51000019
R	Fuse, 15AMP, 600V, CC, Time Delay	2	51000024
S	Fuse Holder, 2 Pole, 600V, 30A	1	51000003
T	Fuse, 5A, 600V, CC (575V)	2	51000012
U	Fuse Holder, 1 Pole, 600V, 30A	2	51000019
V	Fuse, 15AMP, 600V, CC, Time Delay	2	51000024
W	Fuse, 12AMP, 600V, CC, Time Delay	1/3	51000027
X	Cable, 10/5, 600V, 90C (5')	1	15650235

ACTIVATION

#	Part #	Description	5700	7100	80/XL	8600	8900	FSTX	FSTX CL	FSTX FR	FSTX FR LD	FSTX XL	LTSPD	Split 2nd
1	11050007	Alarm, Audible, 24AC/DC, 22.5 (I-Zone)	N	N	Y	N	Y	Y	Y	Y	Y	Y	Y	N
2	11050010	Alarm, Audible, 120VAC,10-TONE, AB	N	Y	Y	Y	Y	Y	Y	Y	Y	Y	Y	N
3	17500025	Controller, Wireless, Act, BTR, 12-24V	N	Y	N	N	Y	Y	Y	Y	Y	Y	Y	Y
4	17500001	Induction Loop Board, 24VDC (<5/28/14)	N	Y	Y	Y	Y	Y	Y	Y	N	N	N	N
5	17500010	Induction Loop Board, 12/24VDC (=>6/20/12)	N	Y	N	Y	Y	Y	Y	Y	Y	Y	Y	Y
6	52000037	Induction Loop Board Harness (<5/28/14)	N	Y	Y	Y	Y	Y	Y	Y	N	N	N	N
7	52000056	Induction Loop Board Harness (=>6/20/12)	N	Y	N	Y	Y	Y	Y	Y	Y	Y	Y	Y
8	53700552	Induction Loop, Kit, Single (<5/28/14)	N	Y	Y	Y	Y	Y	Y	Y	N	N	N	N
9	53700864	Induction Loop, Kit, Dual	N	Y	Y	N	Y	Y	Y	Y	Y	Y	Y	Y
10	55150279	i-COMM ii LCD Interface	N	Y	N	N	N	Y	Y	Y	Y	Y	Y	Y
11	7622	I-Zone Kit	N	N	Y	N	Y	Y	N	Y	Y	Y	Y	N
12	7636	I-Zone Upgrade Kit, Non FasTrax	N	N	Y	N	Y	N	N	N	Y	Y	Y	N
13	7637	I-Zone Upgrade Kit, FasTrax	N	N	N	N	N	Y	N	Y	Y	Y	N	N
14	14500774	I-Zone Sensor Bracket Black	N	N	Y	N	Y	Y	N	Y	Y	Y	Y	N
15	14500775	I-Zone Sensor Bracket Gray	N	N	Y	N	Y	Y	N	Y	Y	Y	Y	N
16	14500783	I-Zone Sensor Bracket Stainless	N	N	Y	N	Y	Y	N	Y	Y	Y	Y	N
17	17900110	I-Zone Cover Gray	N	N	Y	N	Y	Y	N	Y	Y	Y	Y	N
18	17900111	I-Zone Cover Black	N	N	Y	N	Y	Y	N	Y	Y	Y	Y	N
19	17900112	I-Zone Cover Stainless	N	N	Y	N	Y	Y	N	Y	Y	Y	Y	N
20	14501212	Motion Sensor, Mounting Bracket	N	Y	Y	Y	Y	Y	Y	Y	Y	Y	Y	Y
21	55200012	Motion Sensor, Remote Programmer	N	Y	Y	Y	Y	Y	Y	Y	Y	Y	Y	Y
22	55200018	Motion Sensor, FalconXL < 11.5'H	N	Y	Y	Y	Y	Y	Y	Y	Y	Y	Y	Y
23	55200019	Motion Sensor, Falcon >= 11.5'H	N	Y	Y	Y	Y	Y	Y	Y	Y	Y	Y	Y
24	55200021	Motion Sensor, IS40, 12-24V	N	Y	Y	Y	Y	Y	Y	Y	Y	Y	Y	Y
25	55200022	Motion Sensor, LZRI30, 12-35VDC	N	Y	Y	Y	Y	Y	Y	Y	Y	Y	Y	Y
26	55200023	Motion Sensor, MS08,Touchless, 12-24V	N	Y	N	Y	Y	Y	Y	Y	Y	Y	Y	Y
27	55200024	Motion Sensor, IS40XL, 12-24V	N	Y	Y	Y	Y	Y	Y	Y	Y	Y	Y	Y
28	14500024	Photoeye Mounting Bracket	N	Y	Y	Y	Y	Y	Y	Y	Y	Y	Y	Y
29	53700053	Photoeye, 24V, Kit, Thru-beam	N	Y	Y	Y	Y	Y	Y	Y	Y	Y	Y	Y
30	53700122	Photoeye, 24V, Kit, Retro-reflective	N	Y	Y	Y	Y	Y	Y	Y	Y	Y	Y	Y
31	66400001	Photoeye, Reflector, 2 3/4" x 2"	N	Y	Y	Y	Y	Y	Y	Y	Y	Y	Y	Y
32	63900002	Photoeye, Retro-Reflective 20-40VAC/10-55VDC	N	Y	Y	Y	N	Y	Y	Y	Y	Y	Y	Y
33	69300004	Photoeye, Thru-beam Source 20-40VAC/10-55VDC	N	Y	Y	Y	Y	Y	Y	Y	Y	Y	Y	Y
34	63900005	Photoeye, Thru-beam Receiver 20-40VAC/10-55VDC	N	Y	Y	Y	Y	Y	Y	Y	Y	Y	Y	Y
35	63900048	Photoeye, Light Curtain, Receiver, (CE)	N	N	N	N	N	Y	N	Y	Y	N	Y	N
36	63900049	Photoeye, Light Curtain, Transmitter, (CE)	N	N	N	N	N	Y	N	Y	Y	N	Y	N
37	72700213	Pull Cord, Assembly, w/Bracket, Standard	N	Y	Y	Y	Y	Y	Y	Y	Y	Y	Y	Y
38	72700214	Pull Cord, Assembly, w/Bracket, Heated	N	Y	Y	Y	N	N	Y	Y	Y	N	Y	N
39	72700270	Pull Cord, Wireless	N	Y	Y	N	N	Y	Y	Y	Y	Y	Y	Y
40	72700030	Push Button Station Single Green	N	Y	Y	Y	Y	Y	Y	Y	Y	Y	Y	Y
41	72700102	Push Button Station, Open/E-Stop/Close, Nema 4X	N	N	N	N	N	N	N	Y	Y	Y	Y	Y
42	72700269	Push Button, Single, Wireless	N	Y	N	N	N	Y	Y	Y	Y	Y	Y	Y

Continued on the next page

ACTIVATION

#	Part #	Description	5700	7100	80/XL	8600	8900	FSTX	FSTX CL	FSTX FR	FSTX FR LD	FSTX XL	LTSPD	Split 2nd
43	66250020	Radio Control, RCVR, BEA, 433, 12-24V, 1 FN (=>8/26/14)	N	Y	Y	Y	Y	Y	Y	Y	Y	Y	Y	Y
44	73750078	Radio Control, Trans, BEA, 433, 1 BTN (=>8/26/14)	N	Y	Y	Y	Y	Y	Y	Y	Y	Y	Y	Y
45	73750079	Radio Control, Trans, BEA, 433, 2 BTN (=>8/26/14)	N	Y	Y	Y	Y	Y	Y	Y	Y	Y	Y	Y
46	73750080	Radio Control, Trans, BEA, 433, 3 BTN (=>8/26/14)	N	Y	Y	Y	Y	Y	Y	Y	Y	Y	Y	Y
47	11280002	Radio Control Ant w/15' Cable, 318 MHZ (<8/26/14)	N	Y	Y	Y	Y	Y	Y	Y	Y	N	Y	Y
48	53700068	Radio Control, 24V, Kit, 318 MHZ (<8/26/14)	N	Y	Y	Y	Y	Y	Y	Y	Y	N	Y	Y
49	66250016	Radio RCVR, 24V 318 MHZ (<8/26/14)	N	Y	Y	Y	Y	Y	Y	Y	Y	N	Y	Y
50	66250017	Radio RCVR, 24V 300 MHZ (<8/26/14)	N	Y	Y	Y	Y	Y	Y	Y	Y	N	Y	Y
51	73750002	Radio TRANS, 300 MHZ, BTN, 4 (<8/26/14)	N	Y	Y	Y	Y	Y	Y	Y	Y	N	Y	Y
52	73750015	Radio TRANS, 318 MHZ, BTN, 1 (<8/26/14)	N	Y	Y	Y	Y	Y	Y	Y	Y	N	Y	Y
53	73750018	Radio TRANS, 318 MHZ, BTN, 3 (<8/26/14)	N	Y	Y	Y	Y	Y	Y	Y	Y	N	Y	Y
54	73750019	Radio TRANS, 318 MHZ, BTN, 2 (<8/26/14)	N	Y	Y	Y	Y	Y	Y	Y	Y	N	Y	Y
55	54270030	Strobe 120VAC Amber	N	Y	Y	Y	Y	Y	Y	Y	Y	Y	Y	Y
56	54270031	Strobe 120VAC Red	N	Y	Y	Y	Y	Y	Y	Y	Y	Y	Y	Y
57	53700567	Switch, Disconnect w/Handle	N	Y	Y	Y	Y	Y	Y	Y	Y	Y	Y	Y
58	72700011	Switch, Selector, 2 Pos, Key	N	Y	Y	Y	Y	Y	Y	Y	Y	Y	Y	Y
59	72700072	Switch, Selector, 2 Pos (Socket p/n: 17200012)	N	Y	Y	Y	Y	Y	Y	Y	Y	Y	Y	Y
60	72700144	Switch, Selector, 3 Pos, 3 Pole, 12A	Y	N	N	N	N	N	N	N	N	N	N	N
61	VRTL	Virtual Vision, Kit, Stand Alone	N	Y	Y	Y	Y	Y	Y	Y	Y	Y	Y	Y
62	7623	Virtual Vision, Kit, FSTX/FR/LTSPD	N	N	N	N	Y	Y	N	Y	Y	N	Y	Y
63	7624	Virtual Vision, Kit, FSTXCL	N	N	N	N	N	N	Y	N	N	N	N	N
64	7638	Virtual Vision, Kit, FSTXXL	N	N	N	N	N	N	N	N	N	Y	N	N
65	53700862	Warning Device Kit, Relay, i-COMM	N	Y	Y	Y	Y	Y	Y	Y	Y	Y	Y	Y
66	53700863	Warning Device Kit, Relay, PLC	N	N	Y	Y	N	N	N	N	N	N	N	N
67	53700306	Kit, Activation Service Parts (loop, pe, pull, push)	N	Y	Y	Y	Y	Y	Y	Y	Y	Y	Y	Y

Rev. 10.7.14

ARCHITECTURAL DRAWING DUAL BLOWER

4	3	2	1
NEXT ASSEMBLY FINAL	FINAL ASSEMBLY FINAL	REVISION HISTORY	
		REV.	DATE
		A	4/11/2013
		BY	ECN
			6684
			CDH

REQUIREMENTS:
 DUAL BLOWERS, X-FORMERS, & JUNCTION BOXES REQUIRED ON DOORS TALLER THAN 16'-0" & MINIMUM WIDTH OF 7'-0".
 SEE ALSO THE FOLLOWING ARCHITECTURAL APPROVAL DRAWINGS:
 7830A012 ARCHITECTURAL APPROVAL, VERTICAL LIFT, LARGE DRIVER
 7830A013 ARCHITECTURAL APPROVAL, HIGH LIFT, LARGE DRIVER
 7830A014 ARCHITECTURAL APPROVAL, STANDARD LIFT, LARGE DRIVER
 7830A015 ARCHITECTURAL APPROVAL, 45 DEGREE TILT, LARGE DRIVER
 7830A016 ARCHITECTURAL APPROVAL, WRAPBACK, LARGE DRIVER

CONFIDENTIAL	UNLESS OTHERWISE SPECIFIED DIMENSIONS ARE IN INCHES.	MATERIAL	DRAWN BY	CDH
THIS DOCUMENT IS THE PROPERTY OF RITE-HITE® DOORS INC. SUBJECT MATTER HEREIN IS CONFIDENTIAL. DO NOT USE, REPRODUCE, COPY OR DISCLOSE EXCEPT WITH WRITTEN CONSENT OF RITE-HITE® DOORS INC.	TOLERANCES: X = ±.050 XX = ±.010 XXX = ±.005 ANGLE = ±1.0°	THIRD ANGLE PROJECTION	DATE	4/11/2013
			INITIAL ECN	6684
			DATE ISSUED	4/11/2013
© 2013 RITE-HITE® DOORS INC.	ALL SHEETS ARE THE SAME REVISION STATUS	SIZE MODEL	TRXLD	DWG NO
	DO NOT SCALE DRAWING	B	1:32	7830A018
4	3	2	1	SHEET 1 OF 1

ARCHITECTURAL DRAWING WRAP BACK

4	3	2	1
NEXT ASSEMBLY FINAL	FINAL ASSEMBLY FINAL	REVISION HISTORY	
		REV. A	DATE 4/22/2013
		BY CDH	ECN 6684
		NOTE UPDATE & RELEASED TO USE	

APPROVED YES NO AS MARKED

APP'D BY: _____ DATE: _____

SPECIFICATIONS

SPEED: UP TO 18" (457MM) SEC WITH STANDARD VARIABLE FREQUENCY DRIVE. TOP SPEED IS DEPENDENT ON DOOR SIZE.

SIZE: MAXIMUM: 17' (5181MM) wide x 12' (3658MM) high
MINIMUM: 3' (914MM) wide x 10' (3048MM) high

CURTAIN MATERIAL: INSULMAX™ (1" (25MM) OF POLYESTER INSULATION PLACED BETWEEN TWO LAYERS OF Z OZ. URETHANE. STD. - BLUE

SIDE FRAMES: POWDER COATED ALUMINUM EXTRUSION, 4 1/2" (114MM) WIDE x 3 3/4" (91MM) PROJECTION.

DRIVE SYSTEM: 1.5HP / .75HP MOTOR VARIABLE FREQUENCY DRIVE. TRAXION DRIVE SYSTEM - CONSISTING OF A DRIVE GEAR, DRIVE SPHERES AND A COMPOSITE EDGE MATERIAL WHICH IS ATTACHED TO THE CURTAIN.

ELECTRICAL REQUIREMENTS: SINGLE PHASE: 200V, 240V, 60 HZ
 200V, 60 HZ
 240V, 60 HZ
 240V, 50 HZ
 275V, 50 HZ

THERMAL AIR SEAL: STD. - 120 VAC SINGLE PHASE, 60/50 HZ
 OPT. - TRANSFORMER (TO MATCH CROCK VOLT.) (1725MM) x (1172.5MM)

CONTROL BOX: I-COMM/DIGITAL CONTROLLER, VARIABLE FREQUENCY DRIVE. SIZE: 14" x 15" x 8" (354MM x 407MM x 203MM)

CURTAIN RETENTION: WEAR RESISTANT LEAN WIND GUIDES KEEP TENSION ON THE CURTAIN THE ENTIRE TRAVEL. PHOTO EYES STOP CURTAIN AT THE DESIRED POSITION. PHOTO EYES STOP CURTAIN AT THE DESIRED POSITION. PHOTO EYES STOP CURTAIN AT THE DESIRED POSITION. PHOTO EYES STOP CURTAIN AT THE DESIRED POSITION.

SAFETY FEATURES: SOFT EDGE TECHNOLOGY, TWO THRU-BEAM PHOTO EYES MOUNTED AT 18" (457MM) AND 34" (864MM) OFF THE FLOOR.

WARRANTY: LIMITED 1 YEAR PARTS AND LABOR ON ALL COMPONENTS, INCLUDING ELECTRICAL. EXCLUSIVE 1 YEAR MONEY BACK GUARANTEE OF CUSTOMER SATISFACTION.

CURTAIN FANS: TWO CURTAIN FANS PROVIDED. MOUNT IN THE UPPER CORNERS OF DOOR. FANS MUST BE MOUNTED ON THE INSIDE OF THE CURTAIN. FANS MUST MOUNT ON THE INNER SIDE OF THE SLATS. FANS MUST MOUNT ON THE INNER SIDE OF THE CURTAIN, REGARDLESS OF DOOR MOUNT SIDE.

NOTE: 1.) ALTERNATE DIMENSIONS IN BRACKETS, ARE IN MILLIMETERS.

ARCHITECTURAL DRAWING 45° TILT

4	3	2	1
NEXT ASSEMBLY FINAL	FINAL ASSEMBLY FINAL	REVISION HISTORY	
		REV.	DATE
		A	4/22/2013
		B	7/3/2013
		NOTE	
		UPDATE & RELEASED TO USE	
		ECN	BY
		6684	CDH
		UPDATED SPECIFICATION FOR MAX HT.	
		6761	CDH

APPROVED YES NO AS MARKED

APP'D BY: _____ DATE: _____

SPECIFICATIONS

SPEED: UP TO 167' (50.9MM) WITH STANDARD VARIABLE FREQUENCY DRIVE (TOP SPEED IS DEPENDENT ON DOOR SIZE)

SIZE:
 MAXIMUM: 19' (5842MM) wide x 16' (4876MM) high (LARGER THAN 16' TALL, SEE 7830A16)
 MINIMUM: 3' 9" (1143MM) wide x 3' 9" (1143MM) high

CURTAIN MATERIAL: INSULMAX™ (1.75MM) OF POLYESTER INSULATION PLACED BETWEEN TWO LAYERS OF 27 OZ. URETHANE STD. - BLUE PROTECTION.

SIDE FRAMES: POWDER COATED ALUMINUM EXTRUSION, 1/2" (12.7MM) WIDE x 3/4" (19.0MM) PROTECTION.

DRIVE SYSTEM: 1.5HP, 1/2 HP MOTOR, VARIABLE FREQUENCY DRIVE, TRANSDRIVE SYSTEM, CONSISTING OF A DRIVE GEAR, DRIVE SPHERES AND A COMPOSITE EDGE MATERIAL WHICH IS ATTACHED TO THE CURTAIN.

ELECTRICAL REQUIREMENTS:
 SINGLE PHASE: □ 220V, 240V, 60 HZ
 THREE PHASE: □ 208V, 60 HZ
 □ 480V, 3Ø/3W, 60 HZ
 □ 480V, 3Ø/4W, 60 HZ
 □ 575V, 60 HZ

THERMAL AIR SEAL:
 □ STD. - 100 VAC, SINGLE PHASE, 50/60 HZ
 □ OPT. - TRANSFORMER TO MATCH BOX VOLTS (192Z25MM) x 11" (279MM)

CONTROL BOX: I-COM™ DIGITAL CONTROLLER, VARIABLE FREQUENCY DRIVE
 SIZE: 14" x 8" x 8" (355MM x 407MM x 204MM)

CURTAIN RETENTION: WEAR RESISTANT LEAD WIND GUIDES KEEP TENSION ON THE CURTAIN THE ENTIRE TRAVEL OF THE CURTAIN. AUTOMATICALLY RELEASES CURTAIN IN CASE OF ACCIDENTAL IMPACTS TO CURTAIN.

SAFETY FEATURES: SOFT EDGE TECHNOLOGY, TWO THRU-BEAM PHOTO EYES MOUNTED AT 16" (407MM) AND 54" (1372MM) OFF THE FLOOR.

WARRANTY: LIMITED 1-YEAR PARTS AND LABOR ON ALL COMPONENTS, INCLUDING ELECTRICAL. EXCLUSIVE 1-YEAR MONEY BACK GUARANTEE OF CUSTOMER SATISFACTION.

CURTAIN FANS: TWO CURTAIN FANS PROVIDED, MOUNTED IN THE UPPER CORNERS OF DOOR. CURTAIN FANS MUST BE MOUNTED ON THE WARMER SIDE OF THE WALL AND BLOW AIR ON THE WARMER SIDE OF THE CURTAIN, REGARDLESS OF DOOR MOUNT SIDE.

6" OF SPACE BETWEEN ABOVE & BELOW THE TRACK & ANY OBSTRUCTIONS

2 3/4" [69]

45°

DOOR OPENING HT. + 3" [76]

15 7/2" [394]

18" [457]

9" [229]

39" [991]

6 1/4" [157]

OPTIONAL I-ZONE™

DOOR OPENING HT.

DOOR OPENING HT.

DOOR OPENING WIDTH + 14" [356]

2 1/4" [58]

25 3/4" [654]

18" [457]

OPTIONAL STEP-DOWN TRANSFORMER

JUNCTION BOX

BLOWER ASSY

27" [686]

13" [330]

8 3/4" [222]

8 3/4" [222]

DOOR OPENING WIDTH

19 7/2" [495]

DOOR OPNG HT. MINUS 4" [102] (TO BTM OF WALL MNT BRKT.)

OPTIONAL NON-POWERED MANUAL OPNG

END USER DISCONNECT

CONTROL BOX

23 1/4" [591]

CONFIDENTIAL

UNLESS OTHERWISE SPECIFIED DIMENSIONS ARE IN INCHES.

TOLERANCES:
 X = ± .050
 XX = ± .010
 XXX = ± .005
 ANGLE = ± 1.0°

THIRD ANGLE PROJECTION

© 2013 RITE-HITE® DOORS INC.

MATERIAL

DRAWN BY: CDH

DRAWN DATE: 4/11/2013

INITIAL ECN: 6684

DATE ISSUED: 7/3/2013

REFERENCE: ALL SHEETS ARE THE SAME REVISION STATUS

DO NOT SCALE DRAWING

SIZE MODEL: B

TRXLID: 7830A015

SCALE: 1:48

PART#: 1 OF 1

4

3

Abbreviation	Description
AB	Allen Bradley
AC	Alternate Current
ACT	Activation
Amp	Amperage
A/R	As Required
Ass'y	Assembly
BL or BLK	Black
BRD/DRN	Braid or Drain wire
BR or BRN	Brown
BRKT	Bracket
BRK	Brake
BTM	Bottom
BU	Blue
CC	Current Limiting
CE	European Commission
CL	Clean Door
CLR	Cooler Door
CR	Control Relay
CSA	Canadian Standards Association
CT	Control Techniques
Cul	Canadian Underwriters Laboratories
C.W.	Counter Weight
DC	Direct Current
D.O.H.	Door Ordered Height
D.O.W.	Door Ordered Width
DR	Drill
E-Stop	Emergency Stop
e.g.	For Example
etc	Et cetera
Ext	Exterior
Ext/Ext	Exterior / Exterior
F1,2,3	Fuse 1,2,3
FCC	Federal Communications Commission
FDA	US Food and Drug Administration
FHMS	Flat Head Machine Screw
FHWH	Flat Head Washer Head
FR / FZR	Freezer Door
FSTX	FasTrax
GBX	Gearbox
GMP	Good Manufacturing Practice
GN or GRN	Green
GND	Ground
GR	Grade
GY	Gray
HDW	Hardware
HF	Hardware Fault
HHCS	Hex Head Cap Screw
HHMS	Hex Head Machine Screw
HVHMS	Hex Washer head Sheet Metal Screw
H.P.	Horse Power
Hz	Hertz
Illum	Illumination
in	Inches
ind	Induction
Int	Interior
Int/Int	Interior / Interior
Int/Ext	Interior / Exterior
I/O	Input / Output
J-Box	Junction Box
KBPS	Kilobytes per second
KLDR	Time Delay Fuse
KVA	Kilo-Volt Ampere
L	Left
lb	Pounds
LCD	Liquid Crystal Display
LED	Light-Emitting Diode
LH	Left Hand
LHD	Left Hand Drive
L1,2,3	Line Voltage 1, 2, 3
LLC	Limited Liability Company
LTSPD	LiteSpeed
LZR	Laser
L/S	Limit Switch
M/D/Y	Month/Day/Year

Abbreviation	Description
Max	Maximum
Mhx	Mega Hertz
Mil / mm	Millimeters
Min	Minimum
Misc	Miscellaneous
MPH	Miles per hour
MSDC	Mounted Side DC
MSTP	Mounted Side Tie Point
N	Neutral
NFPA	Nation Fire Protection Association
NMDC	Non-Mounted Side DC
NMTP	Non-Mounted Side Tie Point
N/A	Not Available
N.C.	Normally Closed
N.E.C.	National Electric Code
N.O.	Normally Open
N.P.O.	Non-Powered Opening
OB	Obstruction
O.D.H.	Ordered Door Height
O.D.W.	Ordered Door Width
Opt	Optional
OR or ORG	Orange
OSHA	Occupational Safety and Health Administration
Oz	Ounce
Pharma	Pharmaceutical
PB	Push Button
PE	Photoeye
PHLP	Phillips Head
PHSMS	Pan Head Sheet Metal Screw
PK	Pink
P.M.P.	Planned Maintenance Program
Pos	Position
PSA	Pressure Sensitive Adhesive
Pub	Publication
PVC	Polyvinyl Chloride
Qty	Quantity
R	Right
RD	Red
RH	Right Hand
RHD	Right Hand Drive
RHMS	Round Head Machine Screw
R/T	Roller Tube
SD	Secure Digital
SEC	Seconds
SF	Square Foot
S/F	Side Frame
SK	Control Techniques VFD
SPDT	Single Pole Double Throw
SPLT	SplitSecond
S.S. / STNLS	Stainless Steel
STND / STD	Standard
SW	Switch (Disconnect)
Term	Terminal
TIG	Tungsten Insert Gas
UHMW	Ultra High Molecular Weight
USDA	U. S. Department of Agriculture
UV	Ultra Violet
V	Voltage
VFD	Variable Frequency Drive
VL	Vertical Lift
V.V.	Virtual Vision
W.D.	Warning Device
w/	With
w/o	Without
WH	White
X	Controller Input
XL	Extra Large Door
Y	Controller Output
YE	Yellow
ZNC	Zinc
0V	Direct Current Common (Zero V)

Rev. 10.08/14

RITE-HITE DOOR PRODUCT WARRANTY



LIMITED WARRANTY

RITE-HITE Company, LLC and its affiliates (collectively "RITE-HITE") warrants that the FasTrax FR LD door sold to the Owner will be free of defects in design, materials and workmanship (ordinary wear and tear excepted) for the periods set forth below ("Limited Warranty").

One (1) Year on all mechanical and electrical parts.

One (1) Year labor, based on approved travel and labor repair times.

REMEDIES

Parts. RITE-HITE's obligations under this Limited Warranty is limited to repairing or replacing, at RITE-HITE's option, any part which is determined by RITE-HITE to be defective during the applicable warranty period. Such repair or replacement shall be RITE-HITE's sole obligation and the Owner's exclusive remedy under this Limited Warranty.

Labor. RITE-HITE will provide warranty service without charge for labor in the first year of the warranty period. Thereafter, a charge will apply to any repair or replacement under this Limited Warranty.

CLAIMS

Claims under this Limited Warranty must be made (i) within 30 (thirty) days after discovery and (ii) prior to expiration of the applicable warranty period. Claims shall be made in writing or by contacting the representative from whom the Product was purchased directly. Owner must allow RITE-HITE or its agent, a reasonable opportunity to inspect any Product claimed to be defective and shall, at RITE-HITE's option, either (x) grant RITE-HITE or its agent access to Owner's premises for the purpose of repairing or replacing the Product or (y) return of the Product to the RITE-HITE, f.o.b. RITE-HITE's factory.

NOT WARRANTED. RITE-HITE does not warrant against and is not responsible for wear items such as fuses, batteries, bulbs, vision and seals. No implied warranty shall be deemed to cover, damages that result directly or indirectly from: (i) the unauthorized modification or repair of the Product, (ii) damage due to misuse, neglect, accident, failure to provide necessary maintenance, or normal wear and tear of the Product, (iii) failure to follow RITE-HITE's instructions for installation, failure to operate the Product within the Product's rated capacities and/or specified design parameters, or failure to properly maintain the Product, (iv) use of the Product in a manner that is inconsistent with RITE-HITE's guidelines or local building codes, (v) movement, settling, distortion, or collapse of the ground, or of improvements to which the Products are affixed, (vi) fire, flood, earthquake, elements of nature or acts of God, riots, civil disorder, war, or any other cause beyond the reasonable control of RITE-HITE, (vii) improper handling, storage, abuse, or neglect of the Product by Owner or by any third party.

DISCLAIMERS. THIS LIMITED WARRANTY IS EXCLUSIVE AND IN LIEU OF ALL OTHER REPRESENTATIONS AND WARRANTIES, EXPRESS OR IMPLIED, AND RITE-HITE EXPRESSLY DISCLAIMS AND EXCLUDES ANY IMPLIED WARRANTIES OF MERCHANTABILITY OR FITNESS FOR PURPOSE. RITE-HITE SHALL NOT BE SUBJECT TO ANY OTHER OBLIGATIONS OR LIABILITIES, WHETHER ARISING OUT OF BREACH OF CONTRACT, WARRANTY, TORT (INCLUDING NEGLIGENCE AND STRICT LIABILITY) OR OTHER THEORIES OF LAW, WITH RESPECT TO THE PRODUCTS SOLD OR SERVICES RENDERED BY RITE-HITE, OR ANY UNDERTAKINGS, ACTS, OR OMISSIONS RELATING THERETO.

LIMITATION OF LIABILITY. IN NO EVENT SHALL RITE-HITE BE RESPONSIBLE FOR, OR LIABLE TO ANYONE FOR, SPECIAL, INDIRECT, COLLATERAL, PUNITIVE, INCIDENTAL, OR CONSEQUENTIAL DAMAGES, EVEN IF RITE-HITE HAS BEEN ADVISED OF THE POSSIBILITY OF SUCH DAMAGES. Such excluded damages include, but are not limited to, personal injury, damage to property, loss of goodwill, loss of profits, loss of use, cost of cover with any substitute product, interruption of business, or other similar indirect financial loss. Rite-Hite 2.1.14

RITE-HITE DOORS, INC. is covered by one or more of the following U.S. patents, including patents applied for, pending, or issued:

5,579,820, 5,638,883, 5,794,678, 5,887,385, 5,915,448, 5,944,086, 6,089,305, 6,145,571, 6,148,897, 6,192,960, 6,212,826, 6,321,822, 6,325,195, 6,330,763, 6,360,487, 6,481,487, 6,560,927, 6,598,648, 6,612,357, 6,615,898, 6,688,374, 6,698,490, 6,837,296, 6,901,703, 6,942,000, 6,964,289, 7,034,682, 7,045,764, 7,111,661, 7,114,753, 7,151,450, 7,578,097, 7,699,089, 7,748,431, 7,757,437, 8,037,921, 8,167,020, 8,113,265.

RITE-HITE®, RITE-HITE® DOORS, FASTRAX®, FASTRAX® FR, FASTRAX® FR LD, FASTRAX® CL, LITESPEED™, SPLITSECOND™, TRAKLINE™, BUG-SHIELD™, ISO-TEK®, BARRIER® GLIDER, DOK-DOR™ are trademarks of RITE-HITE®.

FCC COMPLIANCE

NOTE: This equipment has been tested and found to comply with the limits for a Class A digital device, pursuant to Part 15 of the FCC Rules. These limits are designed to provide reasonable protection against harmful interference when the equipment is operated in a commercial environment. This equipment generates, uses, and can radiate radio frequency energy and, if not installed and used in accordance with the instruction manual, may cause harmful interference to radio communications. Operation of this equipment in a residential area is likely to cause harmful interference in which case the user will be required to correct the interference at his own expense.

NOTE: Changes or modifications not expressly approved by the party responsible for compliance could void the user's authority to operate the equipment.

This device complies with Part 15 of the FCC Rules. Operation is subject to the following two conditions:

- (1) This device may not cause harmful interference
- (2) This device must accept any interference received, including interference that may cause undesirable operation.

RITE-HITE
8900 N. Arbon Drive
P.O. Box 245020
Milwaukee, Wisconsin 53224-9520
Sales: 414-355-2600
Toll Free: 800-456-0600
Aftermarket: 414-362-3714
Service: 563-589-2722
Service Fax: 563-589-2737
Representatives in All Major Cities

www.ritehite.com