

4

3

DWG NO
A7120116

SHEET
1 OF 1

REV
B

1

NEXT ASSEMBLY

REVISION HISTORY

REV	DESCRIPTION	ECN	DATE	BY	APPROVED
A	ADDED "FOR REFERENCE ONLY" NOTE	11-010	3/29/2011	GDB	
B	UPDATED LOGO AND TITLE BLOCK	14-006	3/31/2014	GDB	

NOTES:

- 1) OPTIONAL FRAMING:
32mm SQUARE TUBING - ZINC PLATED
- 2) FOAM TAPE WATER BARRIER INCLUDED
BETWEEN HEAD FRAME AND TRIM ANGLE

102mm MIN. BUMPER.
355mm-508mm REQUIRED
PENETRATION.

HEAD CURTAIN FABRIC: _____
SIDE CURTAIN FABRIC: _____
ARMOR PLEAT FABRIC: _____

RECOMMENDED TRUCK COVERAGE:
3886mm TO 415mm HIGH X 2438mm TO 2591mm WIDE

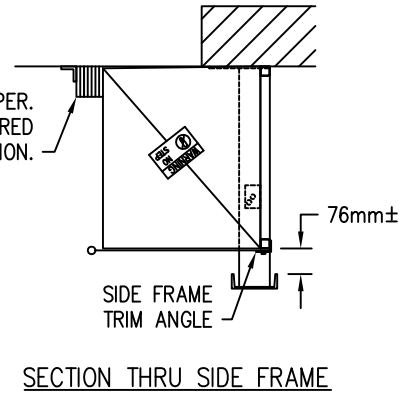

SECTION THRU SIDE FRAME

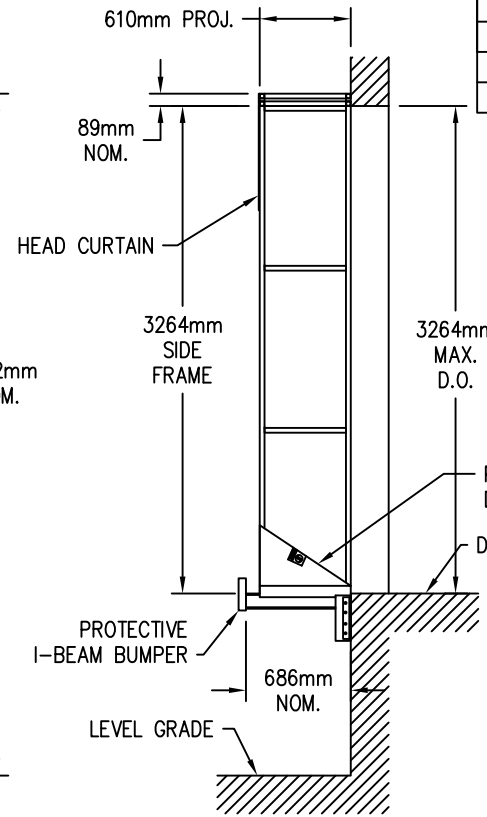

SECTION THRU ELEVATION

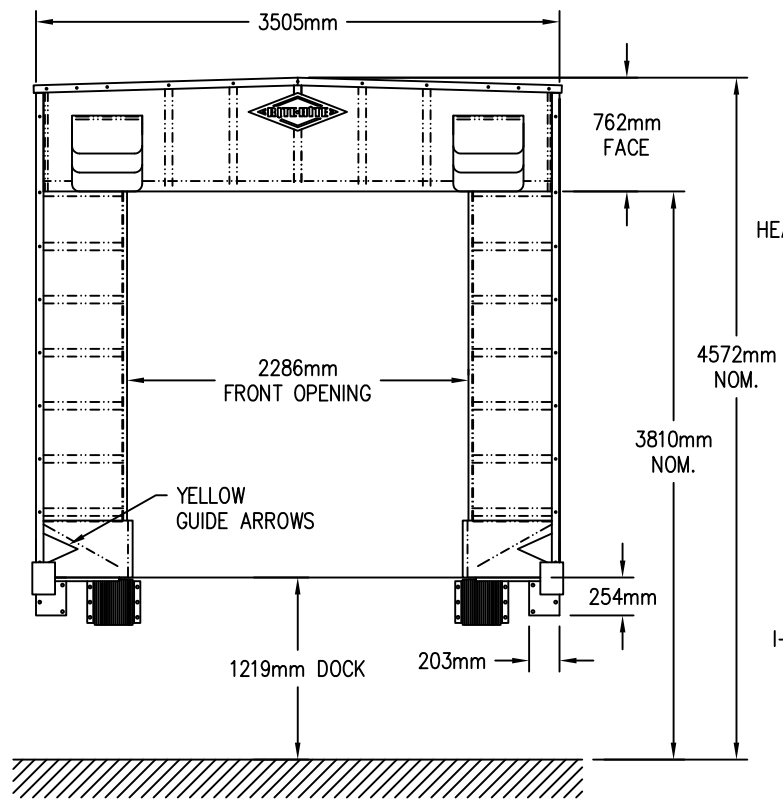

FRONT ELEVATION

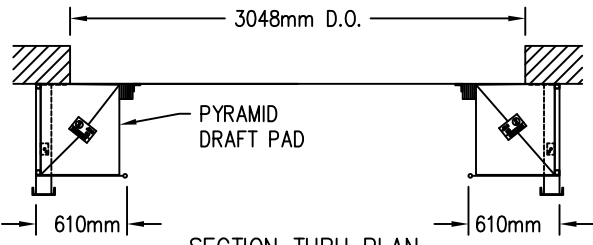

SECTION THRU PLAN

THIS DRAWING IS FOR
REFERENCE ONLY.
DO NOT USE FOR
PRODUCTION PURPOSES.

ITEM	QTY	PART NO.	DESCRIPTION
PARTS LIST / MATERIAL			

INCH TOLERANCES			DO NOT SCALE DRAWING	
OVER	UP TO	+ / -	MM-DD-YY	
0	0.125	0.005	DRAWN BY	DATE 5/5/2009
0.125	0.25	0.010	GDB	
0.25	1.25	0.020	CHECKED BY	DATE
1.25	5	0.030	APPROVED BY	DATE
5	15	0.040	INITIAL ECN	
15	40	0.060	DATE ISSUED	
40	80	0.100	REF	
80	-	0.125		
ANGLES +/- 1 DEG				
FINISH NONE				

RITE-HITE ENVIRONMENTAL ENCLOSURES CORP.

ARCHITECTURAL APPROVAL (METRIC)
WG410 STEEL FRAME OPTION

SIZE B	MODEL NUMBER WG410	DWG NO A7120116	REV B
SCALE 3/8"=1"		PART #	SHEET 1 OF 1

4

3

2

1