

RHA

Dock Leveler

Owners Manual

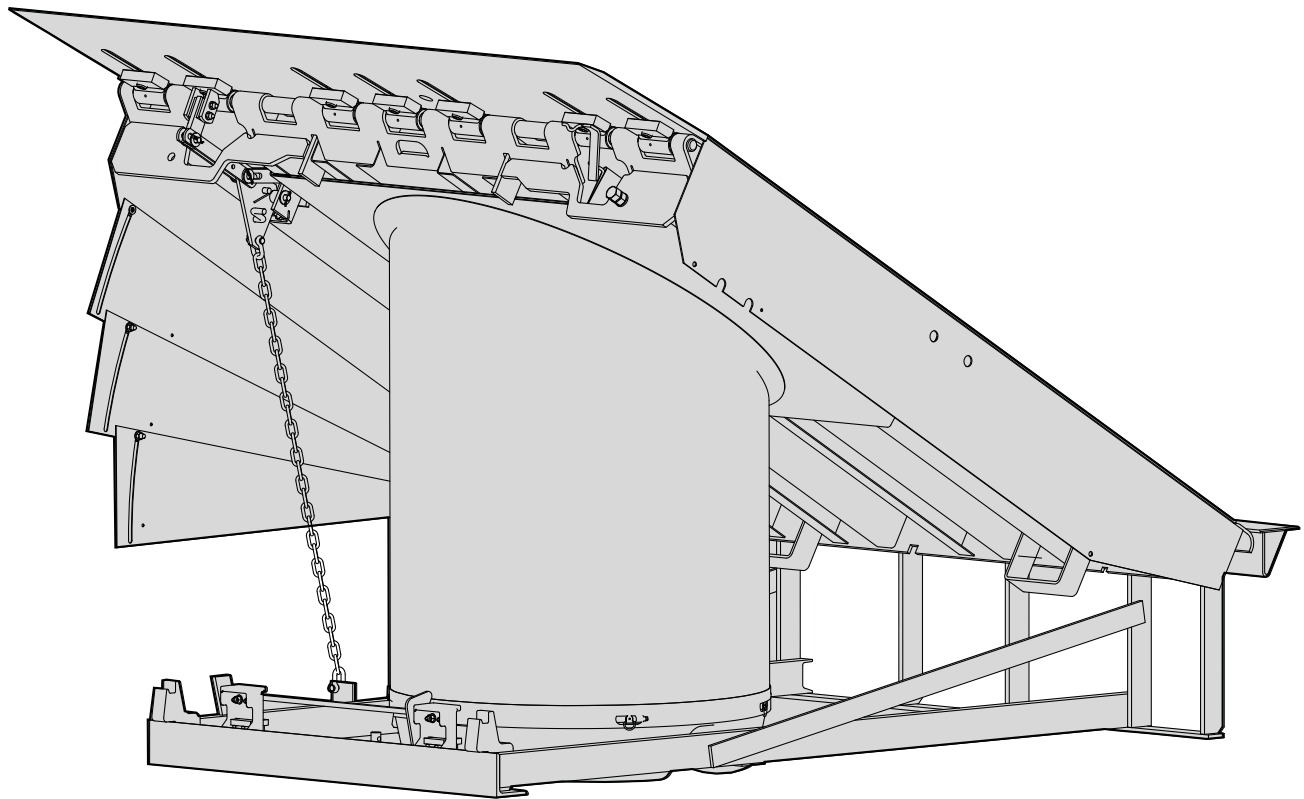

part of the SMOOTH TRANSITION DOK SYSTEM™

RITE
HITE®



**This Manual Covers Dock Levelers Built After Serial Numbers:
082CD401365M and up**

NOTES

TABLE OF CONTENTS

NOTICE TO USER3
SAFETY WARNINGS4
OWNER RESPONSIBILITY7
OPERATION INSTRUCTIONS8
MAINTENANCE PROCEDURES10
LEVELER ADJUSTMENTS / TROUBLESHOOTING12
ELECTRICAL WIRING CHARTS14
ELECTRICAL SCHEMATICS15
RHA REPLACEMENT PARTS20
STANDARD WARRANTYBACK COVER

PRODUCT SPECIFIC WARRANTY

RITE-HITE® warrants the RHA Dock Leveler for five-years parts and one-year labor from date of shipment in accordance with Rite-Hite's Standard Warranty Policy.

NOTICE TO USER

Your local RITE-HITE® representative provides a Planned Maintenance Program (P.M.P.) which can be fitted to your specific operation. Call your local representative or the RITE-HITE® Corporation at 414-355-2600.

The RITE-HITE® products in this manual are covered by one or more of the following U.S. patents: 5,271,183; 5,323,503; 5,546,623; 5,553,987; 5,582,498; 5,664,930; 5,702,223; 5,762,459 (RE: 37,570); 5,882,167; 6,065,172; 6,070,283; 6,085,375; 6,092,970; 6,106,212; 6,116,839; 6,190,109; 6,220,809; 6,276,016; 6,311,352; 6,318,947; 6,322,310; 6,360,394; 6,368,043; 6,431,819; 6,488,464; 6,499,169; 6,502,268; 6,505,713; 6,524,053; 6,634,049; 6,654,976; 6,726,432; 6,773,221; 6,832,403; 6,880,301; 6,892,411; 7,032,267; 7,062,814; 7,134,159; 7,213,285; 7,216,391; 7,363,670; 7,380,305; 7,503,089; 7,553,431; 7,584,517; 7,681,271; 7,823,239; 7,841,823; 7,877,831 and pending U.S and foreign patent applications. RITE-HITE®, LEVEL-RITE®, THINMAN™, SAFE-T-LIP®, HYDRACHEK®, WHEEL-LOK™, DOK-LOK®, DUAL-DOK®, SAFE-T-STRUT™, DOK-COMMANDER®, JUMBO™, HYDRA-RITE™, SAFE-T-GATE®, and SMOOTH TRANSITION DOK SYSTEM™, are trademarks of RITE-HITE® Corporation.

SAFETY WARNINGS

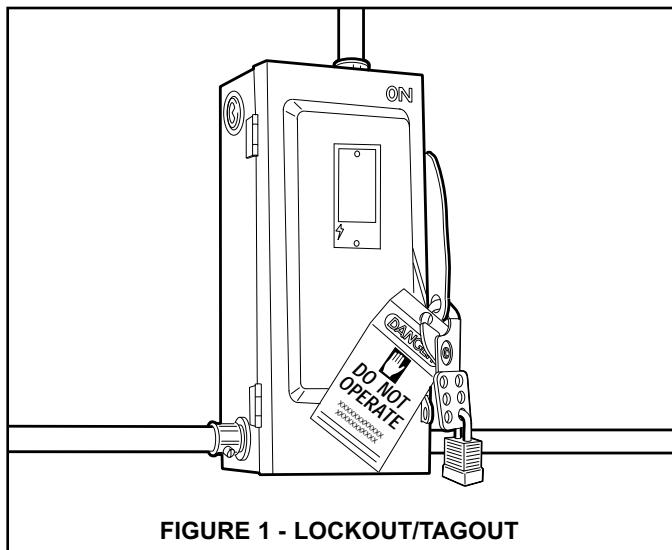

FIGURE 1 - LOCKOUT/TAGOUT

WARNING

When working with electrical or electronic controls, make sure that the power source has been locked out and tagged out according to OSHA regulations and approved local electrical codes.

LOCKOUT/TAGOUT PROCEDURES

The Occupational Safety and Health Administration (OSHA) requires, in addition to posting safety warnings and barricading the work area (including, but not limited to, trucking office and loading docks), that the power supply has been locked in the OFF position or disconnected. It is mandatory that an approved lockout device is utilized. An example of a lockout device is illustrated. The proper lockout procedure requires that the person responsible for the repairs is the only person who has the ability to remove the lockout device.

In addition to the lockout device, it is also a requirement to tag the power control in a manner that will clearly note that repairs are under way and state who is responsible for the lockout condition. Tagout devices have to be constructed and printed so that exposure to weather conditions, or wet and damp locations, will not cause the tag to deteriorate or become unreadable.

RITE-HITE® does not recommend any particular lockout device, but recommends the utilization of an OSHA approved device (refer to OSHA regulation 1910.147). RITE-HITE® also recommends the review and implementation of an entire safety program for the Control of Hazardous Energy (Lockout/Tagout). These regulations are available through OSHA publication 3120.

DANGER

This is the highest level statement. Failure to follow the listed instructions will most likely result in severe injury or death.

CAUTION

The statements used with this level of warning deal with a safe operating procedure. If the procedure is ignored the possibility of personal injury may exist.

WARNING

This is a statement of serious hazard. Failure to follow the listed instructions could place the individual at risk of serious injury or death.

IMPORTANT

IMPORTANT is used to draw attention to a procedure that needs to be followed to prevent machine damage.

OTHER IMPORTANT OPERATIONAL SAFETY WARNINGS

DANGER

Never be under the dock leveler platform or lip without:

- Installing the Safe-T-Strut™ or other supporting device.
- If lip needs to be extended, follow procedures shown under Safety Devices on the following page.
- Turning off power to the control box.
- Locking out and tagging out the main power source, as shown under Safety Warnings on preceding page.

WARNING

Always barricade the dock leveler at ground level and dock level from any form of traffic when maintenance is required.

CAUTION

Inspect the dock leveler monthly to ensure that there are no broken or worn parts which could cause injury to personnel or damage to the equipment.

WARNING

- Before starting installation or maintenance, check and follow the safety procedures of the facility where the dock leveler is being installed.
- Never enter a truck/trailer until its brakes are set, air has been dumped from air ride suspension (if applicable), and you have visually inspected to be sure truck/trailer is securely held in place by a vehicle restraint or wheel chock per OSHA regulations.
- Never operate the leveler with you, anyone, or anything on, or in front of the leveler, or without a truck/trailer parked in position, or from on the truck/trailer bed.
- DO NOT operate with anyone under platform or in front of the lip.
- When leveler is not in use, always store it so that it is supported by the lip supports and that it is level with the surrounding dock floor.
- If a malfunction does occur, always call your authorized RITE-HITE® service representative immediately.

SAFETY DEVICES

DANGER

Never be under the dock leveler platform or lip without:

- Installing the Safe-T-Strut™. See below right. This can be done with the assistance of another person by:
 - Raise leveler until platform reaches its highest position and lip extends. Continue to maintain this position.
 - Then have assistant insert the smaller end of the Safe-T-Strut™ through the hole in the middle of the leveler lip and place the strut's wider open end over the base located on the leveler's front frame. Align the holes on the base and the Safe-T-Strut™ so that the leveler may be secured with the retaining pin and safety clip.
 - Release the pushbutton on powered levelers allowing the Safe-T-Strut™ to rest on the underside of the lip.
- Lockout/Tagout power supply.
 - Turn off the power to the control box.
 - Lockout/tagout the main power source, as shown under Safety Warnings on the inside front cover of this manual.
 - Always barricade the leveler at dock level and drive level to prevent any unauthorized use of the leveler.

Remove the Maintenance Support.

- For Safe-T-Strut™ removal, have an assistant raise the leveler to its highest position with lip fully extended. Release the safety clip and remove retaining pin. Lift strut off base, and remove from lip. Return the Safe-T-Strut™ to the proper storage position.
- If you are unable to install the Maintenance Support properly, contact your authorized RITE-HITE® Service Representative or RITE-HITE® Customer Service at 1-414-355-2600.

CAUTION

- Post warnings and barricades at dock level and at drive level to indicate that work is being done around and under the leveler platform.
- Lockout/Tagout power to the leveler and post warnings when work is being performed on the leveler.

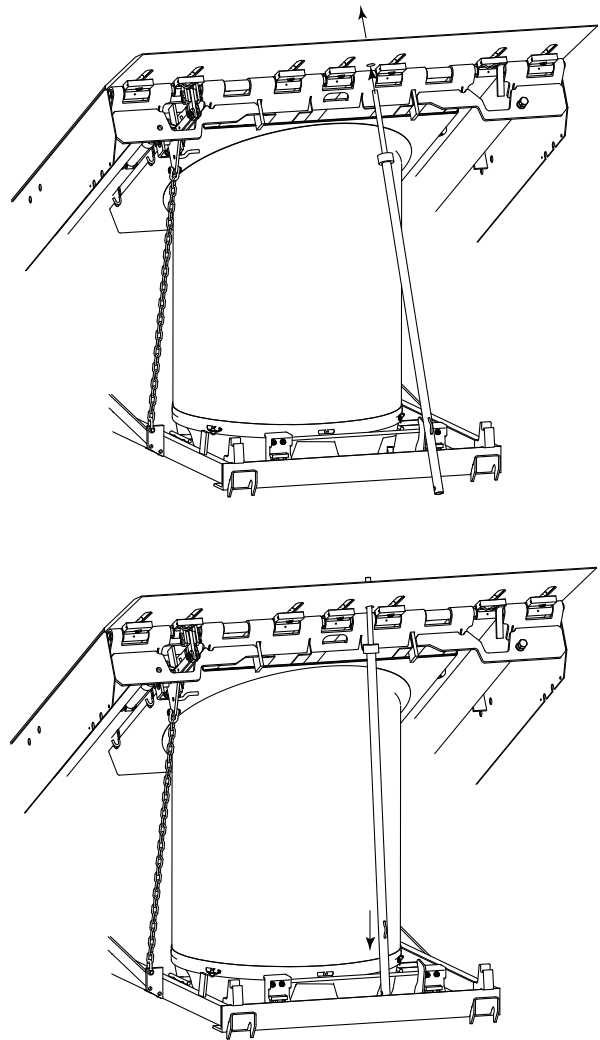

FIGURE 2 - INSTALL SAFE-T-STRUT™ SUPPORT

OWNER RESPONSIBILITY

1. The owner should recognize the inherent danger of the interface between dock and transport vehicle. The owner should, therefore, train and instruct operators in the safe use of dock equipment in accordance with the information provided below. The manufacturer shall publish, provide to the initial purchaser, and make the following information readily available to owners:
 - Installation instructions
 - Recommended initial and periodic inspections procedures
 - Maintenance procedures
 - Operating instructions
 - Descriptions or specifications for replaceable or repairable parts
 - Tables identifying the grade (slope) for all variations of length or configuration of the dock equipment, and
 - Information identifying the maximum uncontrolled drop encountered upon sudden removal of support while within the working range of the equipment.

It shall be the responsibility of the owner to verify that the material listed in this section has been received and that it is made available for the instruction and training of personnel entrusted with the use or maintenance of the dock equipment.
2. When a transport vehicle is parked at a loading dock, it is important that the vehicle is relatively perpendicular to the dock face and in close contact with at least one of the dock bumpers.
3. Nameplates, cautions, instructions, and posted warnings shall not be obscured from the view of operating or maintenance personnel for whom such warnings are intended.
4. Manufacturer's recommended periodic maintenance and inspection procedures in effect at date of shipment shall be followed, and written records of the performance of these procedures should be kept.
5. As with any piece of machinery, dock equipment requires routine maintenance, lubrication, and adjustments. Your local RITE-HITE® representative offers owners the option of a Planned Maintenance Program (P.M.P.). As part of this service, your local RITE-HITE® representative will do all routine maintenance, lubrication, and adjustments.
6. Dock equipment that is structurally damaged shall be removed from service, inspected by a manufacturer's authorized representative, and repaired as needed before being placed back in service.
7. The manufacturer shall make available replacement nameplates, caution/instruction labels, and operating/maintenance manuals upon request of the owner. The owner shall see that all nameplates, caution/instruction markings or labels are in place and legible, and that the appropriate operating/maintenance manuals are provided to users.
8. Modifications or alterations of dock equipment shall be made only with written permission of the original manufacturer. These changes shall also satisfy all safety recommendations of the original equipment manufacturer for the particular application of the dock equipment.
9. In order to be entitled to the benefits of the standard product warranty, the dock equipment must have been properly installed, maintained and operated within its rated capacities and/or specific design parameters, and not otherwise abused.
10. It is recommended that trailers equipped with air ride suspensions should remove the air from the suspension to minimize trailer bed drop, prior to loading or unloading.
11. When industrial trucks are driven on and off transport vehicles during the loading and unloading operation, the brakes on the transport vehicle shall be applied and wheel chocks or a positive restraining device shall be engaged.
12. In selecting dock equipment, it is important to consider not only present requirements but also future plans or adverse environments.

OPERATION INSTRUCTIONS

NORMAL OPERATION

1. Activate the leveler by pushing and holding the RAISE button until leveler is fully raised and lip is fully extended. See figure 3.

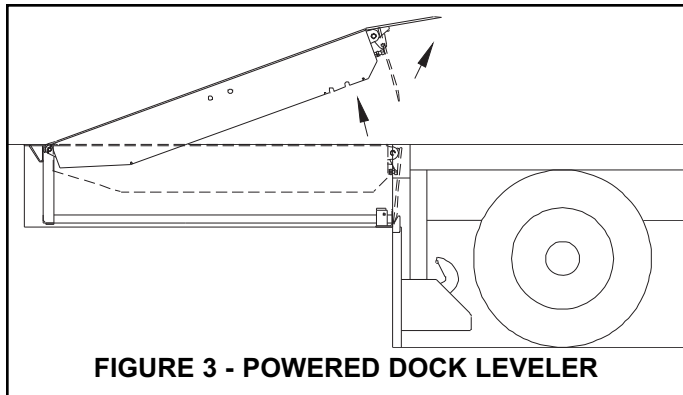

2. When lip is fully extended, release RAISE button. The leveler will automatically lower onto the truck/trailer bed. See figure 4.

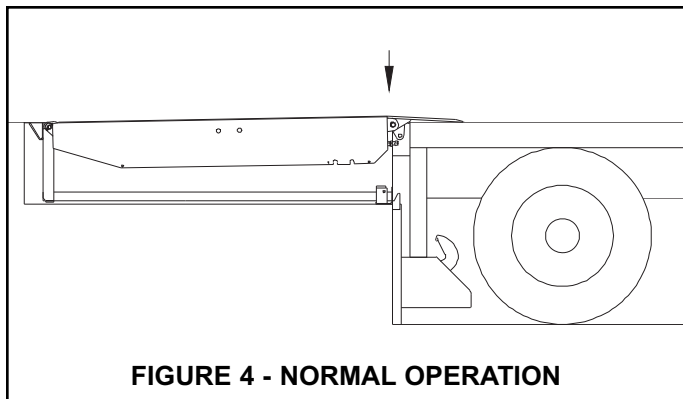

3. See *Storing Leveler*.

NOTES:

- a. **Levelers without Automatic Return to Dock (ARTD)** If the truck/trailer departs, the leveler will move to its lowest position and the lip will fall to the pendant position inside the dock bumpers. See *Storing Leveler*.
- b. **Levelers with Automatic Return to Dock (ARTD)** If the lip is on the truck/trailer and the truck departs, the leveler will move to its lowest position and the lip will begin to lower. As the lip drops toward the pendant position, the ARTD system automatically returns the leveler to the stored position without operator assistance.

BELOW DOCK LOADING OPERATION

1. Activate the leveler by pushing and holding the RAISE button until leveler is fully raised and lip is fully extended. See figure 3.
2. When lip is fully extended, release RAISE button. If equipped with safety legs, pull and hold the Safety Leg Chain as the leveler lowers automatically onto the truck/trailer bed. See figure 5.

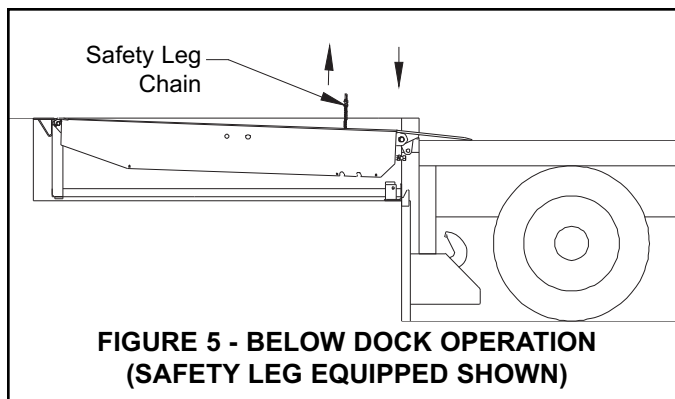

3. When loading/unloading is complete, continue with normal operation or return the leveler to stored position. See *Storing Leveler*.

OPERATION INSTRUCTIONS CONT.

DOCK LEVEL (OR LOWER) END LOADING OPERATION

1. Activate the leveler by pushing and holding the RAISE button until leveler lip clears the lip supports. See figure 6.

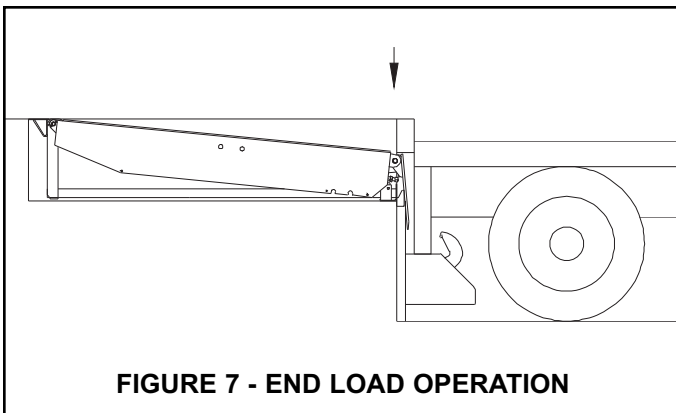
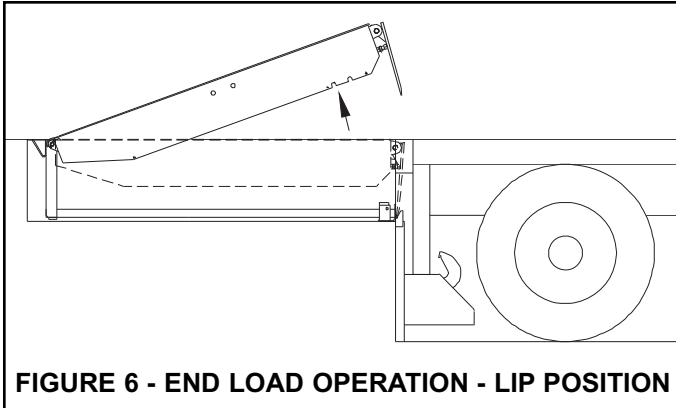

2. Release RAISE button and as platform is lowering pull and hold the Safety Leg Chain, if equipped. The leveler will lower to the below dock position with the lip positioned between the face of the loading dock and the truck/trailer bed. See figure 7 & 8.

NOTE: End loads at dock level and above can be handled with the leveler in its stored position on units without a Safe-T-Lip®.

3. When loading/unloading is complete, continue with normal operation or return the leveler to stored position. See *Storing Leveler*.

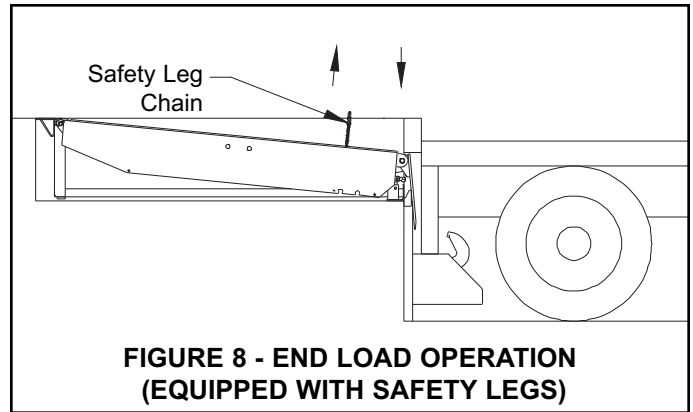

STORING LEVELER

1. To store the leveler, push and hold the RAISE button until leveler is about 6 inches above dock level and lip is fully pendant.
2. Release RAISE button. Leveler will lower to dock level with lip resting in the lip supports. See figure 9.

NOTE: On Powered levelers with Automatic Return to Dock (ARTD). If the lip is on the truck/trailer and the truck departs, the leveler will move to its lowest position and the lip will begin to lower. As the lip drops toward the pendant position, the ARTD system automatically returns the leveler to the stored position without operator assistance.

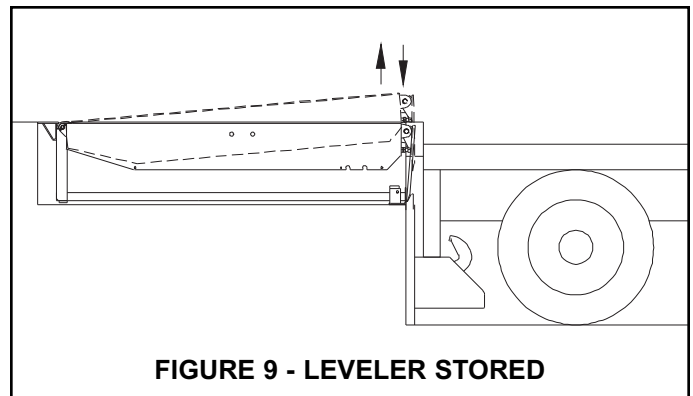

MAINTENANCE PROCEDURES

WARNING

Read and obey these instructions to prevent personal injury.

- Post safety warnings and barricade work area, at dock level and at ground level, to prevent unauthorized use of the dock position before maintenance has been completed.
- Make sure to install the maintenance support strut before proceeding with any repair work.

SUGGESTED LEVELER MAINTENANCE

NOTE: Follow maintenance procedures below as outlined. Include the specific steps for your leveler model.

NOTE: Your local RITE-HITE® representative provides a Planned Maintenance Program (P.M.P.) which can be fitted to your specific operation. Call your local representative.

Daily

1. Remove debris on and around leveler. Be sure the hinge section of the lip and the platform is clean.
2. Check unit for proper operation.

90 Days

1. Perform all Daily Maintenance.
2. Clean pit.
3. Inspect lip out mechanism (pins, lip crank, links, chains and shackles). Replace if worn.
4. Lubricate the leveler with the proper lubricants. See figure 10.

NOTE: Items that use Anti-Seize lubricant only require lubrication every 360 Days.

5. Inspect all weather seals (if installed) and replace if worn or damaged.
6. Inspect dock bumpers. Four inches (4") of bumper protection is required. Worn, torn, loose or missing bumpers must be replaced.

7. Check conditions of concrete, angles and welds. Repair or replace if necessary.
8. Inspect structure, hinge pins, clevis pins and cotter pins for abnormal wear.
9. Inspect all conduit boxes, control boxes and electrical connections for damage. Repair or replace if worn or damaged.

NOTE: If control box has evidence of condensation.

a. Inspect conduit. Conduit should be routed to enter through the bottom or side of the enclosure. A drip leg may be needed if the conduit is filling with water.

b. Inspect the seal on the cover of the enclosure. The seal should be securely adhered to the cover with no signs of peeling or bubbling. Repair or replace if worn or damaged.

c. For non-metallic enclosures, breather vent part number 122130 may be installed. The vent is NEMA 4X and will not change the environmental rating of the control box.

10. With the leveler supported by the maintenance strut, inspect the air tower for damage. Replace if worn or damaged.

360 Days

1. Perform Daily and 90-Day Maintenance.
2. Check and tighten control box mounting hardware.
3. Retorque all shoulder bolts on units equipped with Safe-T-Lip®. See Figure 11.

LUBRICATION CHART

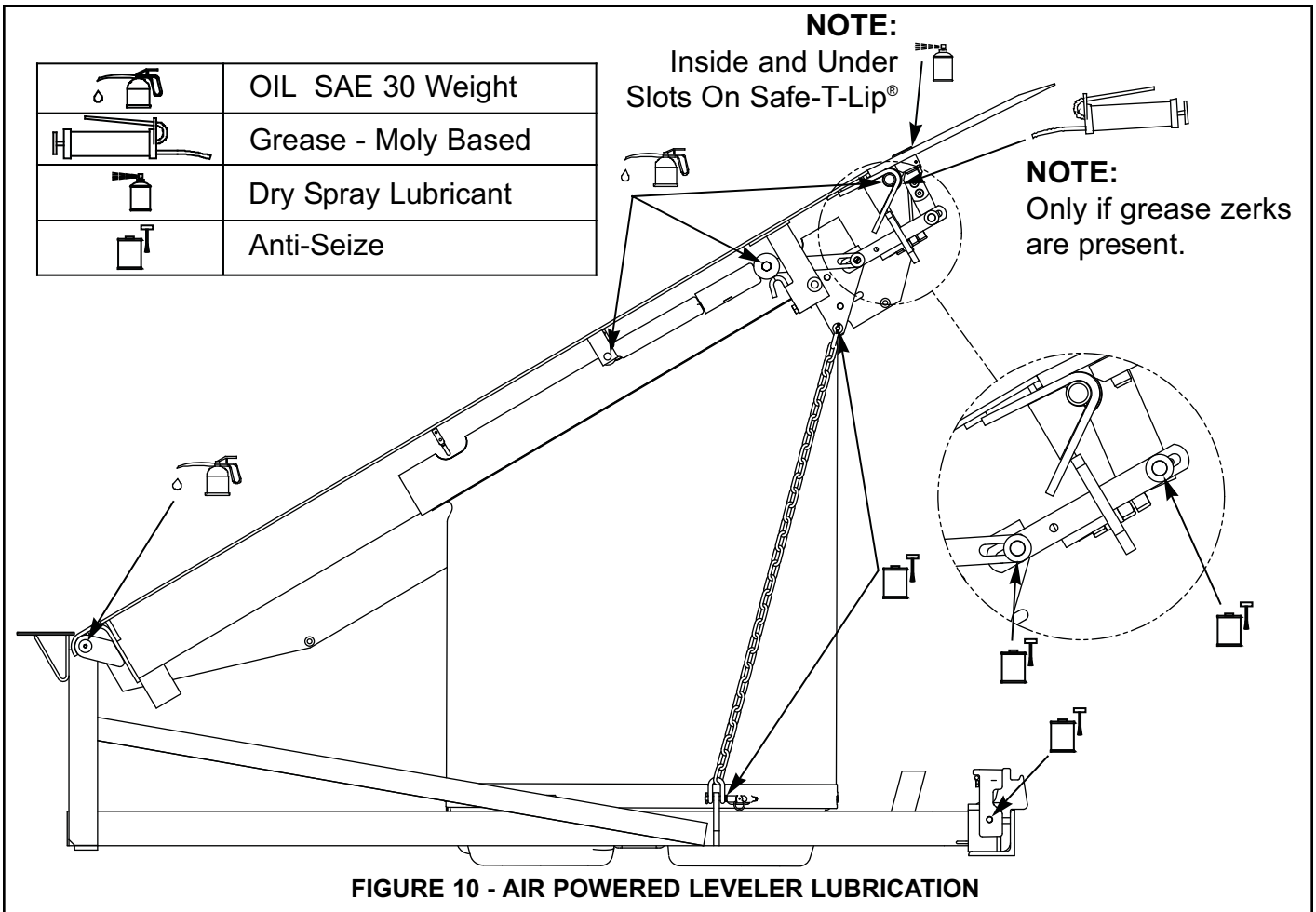

Safe-T-Lip® Shoulder Bolt Torque Specifications

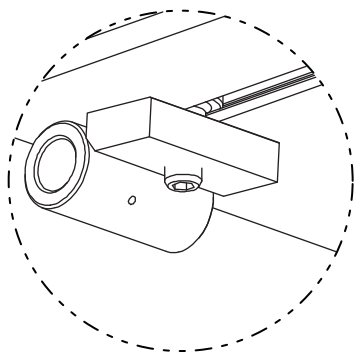

- Torque Range: 290 - 310 Ft-Lbs.

FIGURE 11 - SHOULDER BOLT TORQUE

LEVELER ADJUSTMENTS

LIP LATCH BOLT ADJUSTMENT

If the lip does NOT latch when the leveler is fully raised and remain latched as the platform lowers, the lip latch bolt may need to be readjusted. Use the following procedure to readjust the lip latch bolt:

1. Loosen the jam nuts on the lip latch bolt. See figure 12.
2. Turn the bolt clockwise one full turn at a time. See figure 12.
3. Tighten the jam nuts on the lip latch bolt.
4. Follow normal operating procedures to verify that the lip latch has been adjusted correctly and holds the lip out as the platform lowers. Test unit three times to make sure it latches all three times, if not readjust.

NOTE: DO NOT over adjust the lip latch bolt. When properly adjusted the lip should just latch in. If you have over adjusted the lip may not release, or it will bend the delatch rod over time. Re-adjust bolt until lip no longer latches and then make one full turn of the bolt until lip just latches.

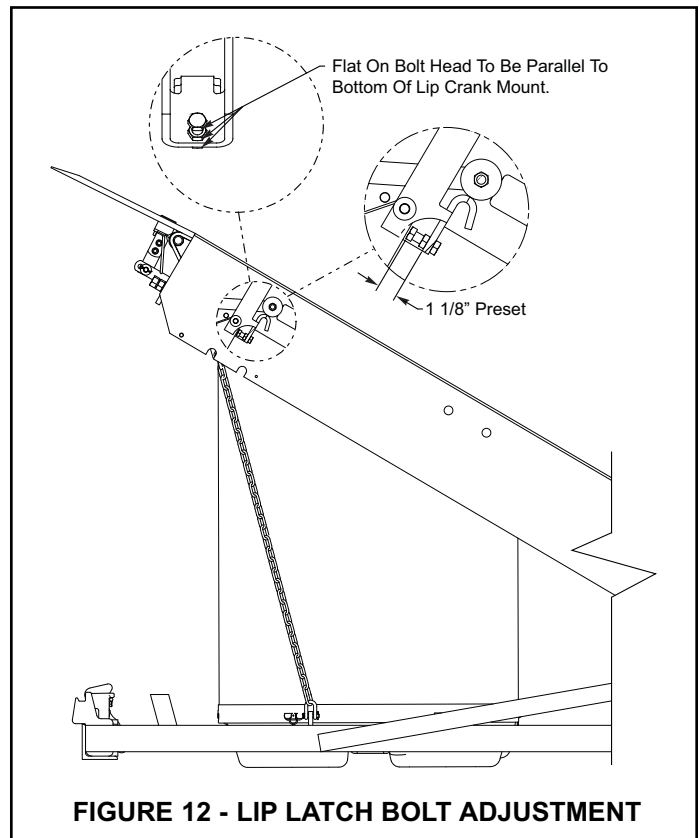

FIGURE 12 - LIP LATCH BOLT ADJUSTMENT

LIP STOP BOLT ADJUSTMENT

The lip stop bolt adjusts the position of the lip when the leveler is stored to allow the lip to be centered on lip supports when stored.

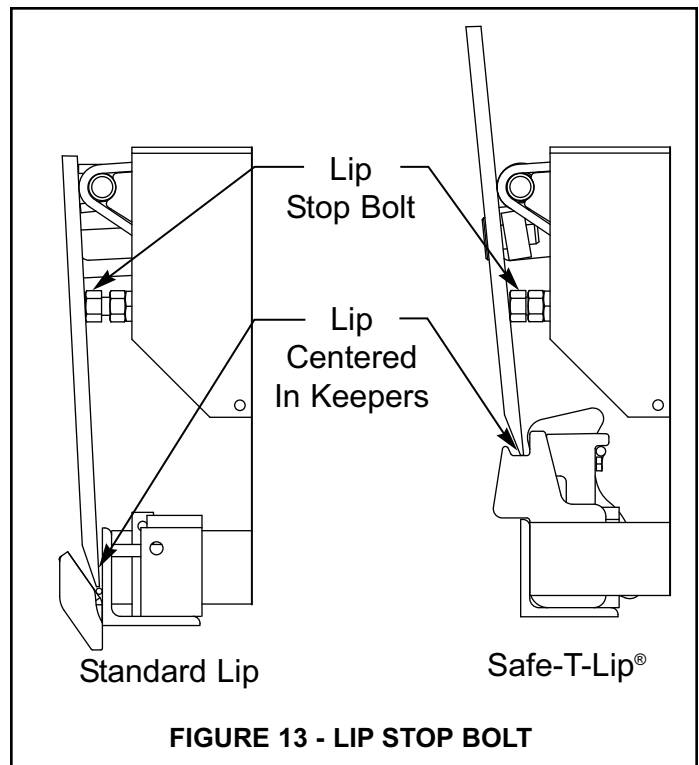

FIGURE 13 - LIP STOP BOLT

LEVELER TROUBLESHOOTING

Problem	Probable Cause	Solution
1. Platform does not raise	<ul style="list-style-type: none"> a. Power has been disconnected. b. The blower motor and/or control box has been miswired. c. The pushbutton and/or contact block does not function properly. d. Overload relay tripped. e. The blower motor has failed. f. Check air tower assembly for damage. 	<ul style="list-style-type: none"> a. Verify that power has not been disconnected. Verify that disconnect circuit breaker or fuses are not tripped. b. Verify that the blower motor and/or control box have been wired according to the wiring schematic. c. Replace pushbutton operator and/or contact block. d. Push RESET on overload relay, if applicable. e. Replace air tower assembly. f. Repair or replace components if necessary.
2. Lip will not extend	<ul style="list-style-type: none"> a. Debris in lip hinge or lubrication needed. 	<ul style="list-style-type: none"> a. Remove dirt, debris and corrosion from lip hinge and/or lubricate. See maintenance procedures.
3. Lip remains fully or partially extended	<ul style="list-style-type: none"> a. Debris in lip hinge. b. Lip out mechanism or below dock actuator is damaged. c. Lip impacted or bent. 	<ul style="list-style-type: none"> a. Remove debris from lip hinge. b. Repair or replace damaged components. c. Lubricate per maintenance procedures or replace lip.
4. Platform does not lower	<ul style="list-style-type: none"> a. Debris under platform. 	<ul style="list-style-type: none"> a. Remove debris.
5. Platform raises slowly	<ul style="list-style-type: none"> a. Air tower system damaged. b. Weight on platform. 	<ul style="list-style-type: none"> a. Repair or replace damaged components if necessary. b. Remove weight on platform.
6. Lip does not latch	<ul style="list-style-type: none"> a. Lip latch adjustment bolt out of adjustment. 	<ul style="list-style-type: none"> a. Readjust lip latch bolt. See figure 12.

ELECTRICAL WIRING CHARTS

Average Motor Loads (Amps)				
	Air Levelers	Hydraulic Leveler		
		Base		Hydra-Rite
		3/4 hp	1hp	1hp
110-120/1	12.0	10.0	N/A	21.2
208-230/1	7.0	5.0	N/A	10.6
208-230/3	N/A	N/A	3.8	5.4 - 4.3
380-415/3	N/A	N/A	2.5	2.3
440-480/3	N/A	N/A	1.9	2.5
575-600/3	N/A	N/A	1.7	2.4

Minimum Wire Size Chart for Various Line Lengths and Line Loads										
			Line Length (In Feet)							
			0-50	51-100	101-150	151-200	201-250	251-300	301-350	351-400
110-120/1	1300 watts	Air Powered Levelers	12	8	6	6	4	4	3	2
110-120/1	3/4 hp	Hydraulic Levelers	12	10	8	6	4	4	4	3
110-120/1	1 hp	Hydraulic Levelers	10	8	6	4	4	3	2	1
110-120/1	1 hp	Hydraulic Hydra-Rite	8	6	4	3	2	1	1/0	1/0
208-240/1	1533 watts	Air Powered Levelers	14	14	12	10	10	8	8	8
208-240/1	3/4 hp	Hydraulic Levelers	14	14	14	12	10	10	10	8
208-240/1	1 hp	Hydraulic Levelers	14	12	12	10	8	8	8	6
208-240/1	1 hp	Hydraulic Hydra-Rite	14	12	10	8	8	6	6	6
208-240/3	1 hp	Hydraulic Levelers	14	14	12	12	10	10	10	8
380-415/3	1 hp	Hydraulic Levelers	14	14	14	14	14	14	14	14
440-480/3	1 hp	Hydraulic Levelers	14	14	14	14	14	14	14	14
575-600/3	1 hp	Hydraulic Levelers	14	14	14	14	14	14	14	14

ELECTRICAL SCHEMATICS

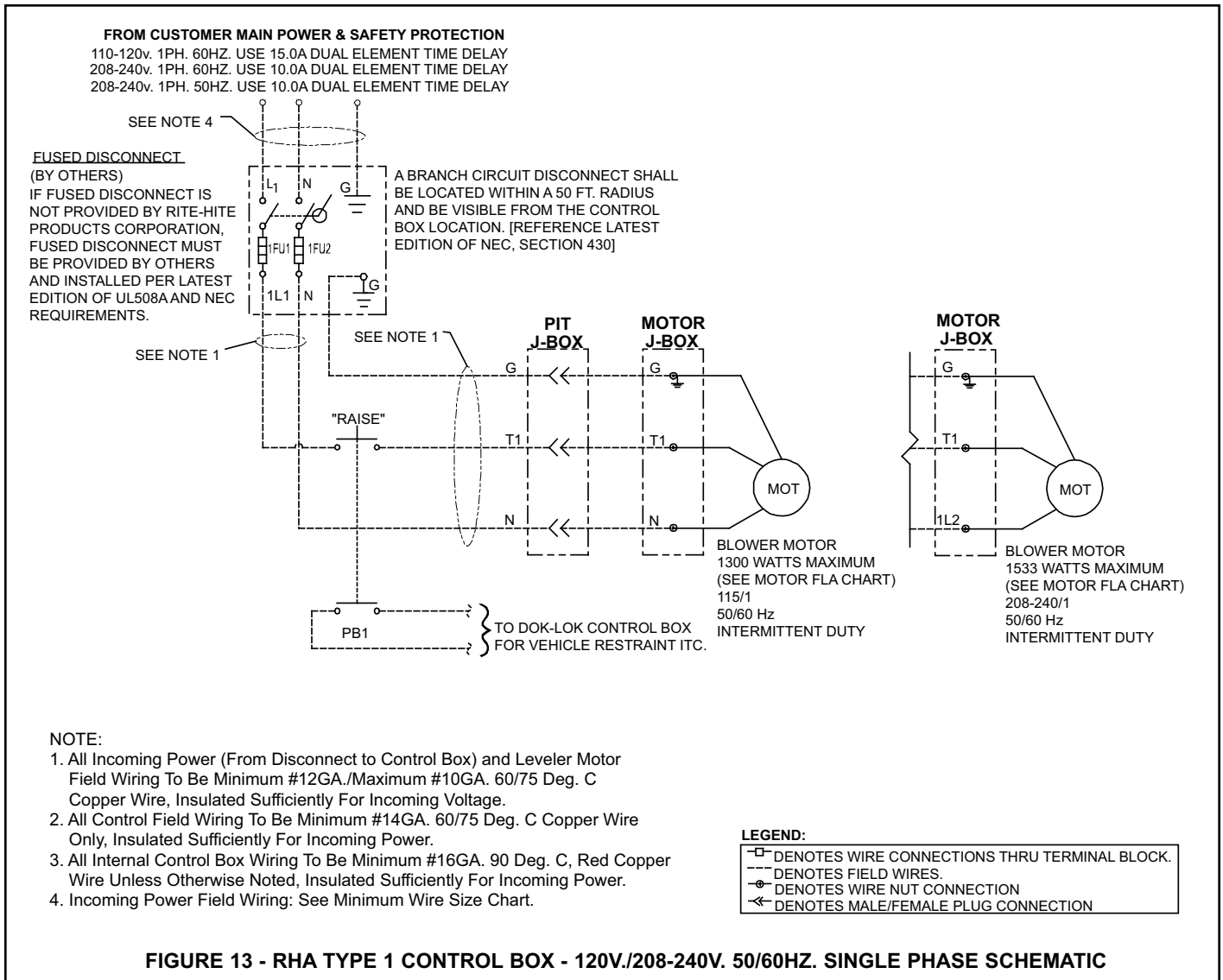
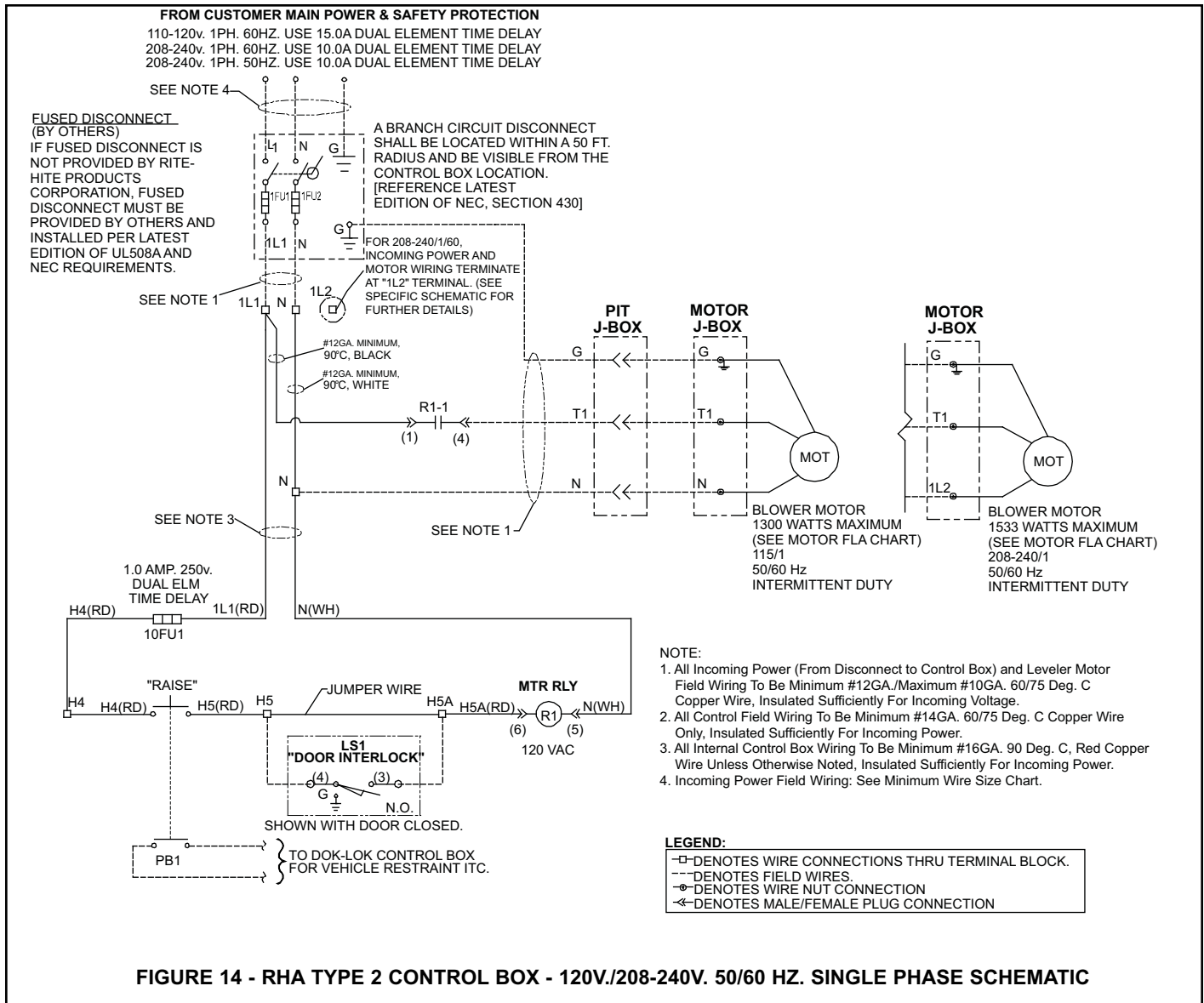

FIGURE 13 - RHA TYPE 1 CONTROL BOX - 120V./208-240V. 50/60HZ. SINGLE PHASE SCHEMATIC

ELECTRICAL SCHEMATICS CONT.



ELECTRICAL SCHEMATICS CONT.

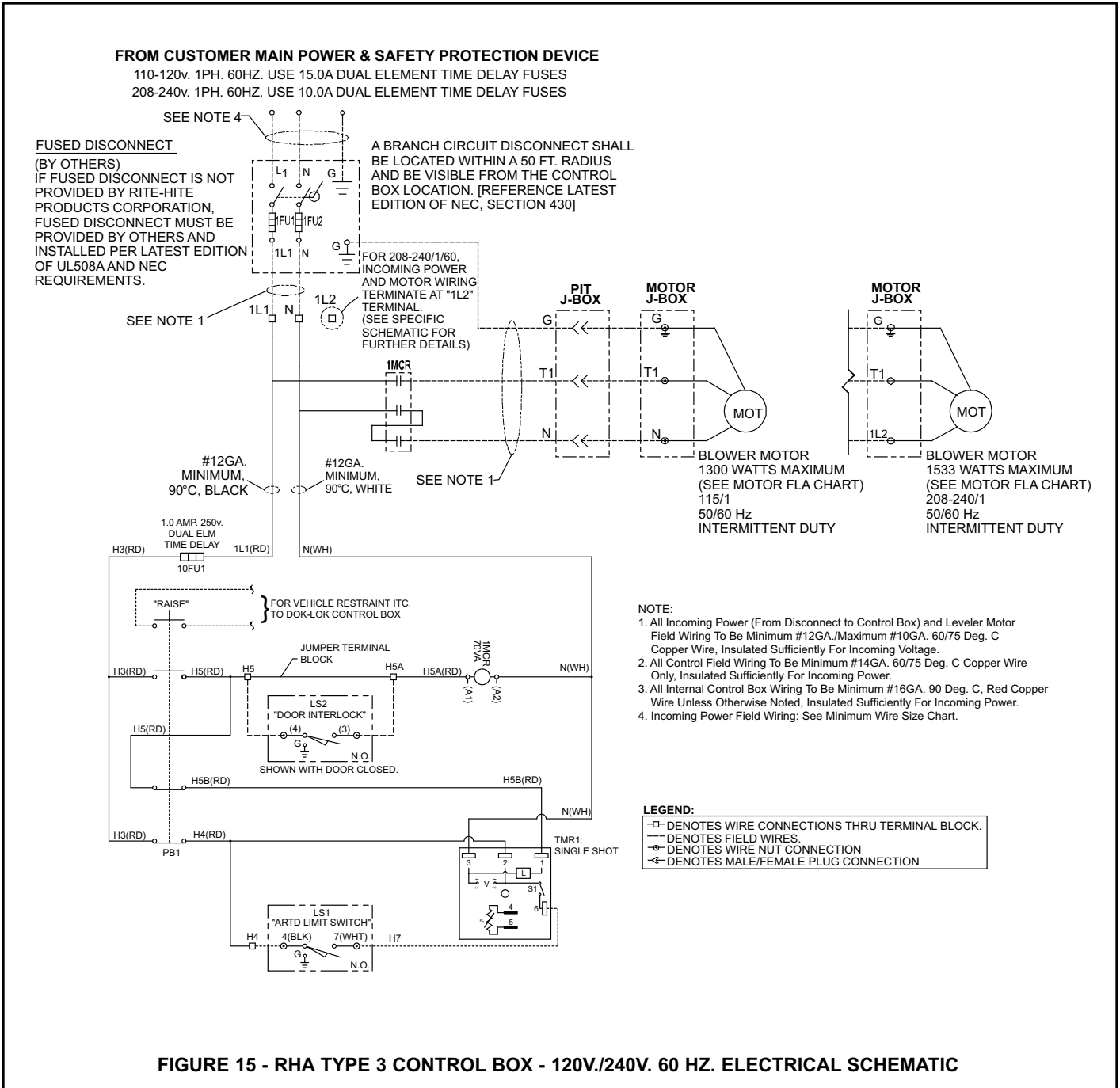

FIGURE 15 - RHA TYPE 3 CONTROL BOX - 120V./240V. 60 HZ. ELECTRICAL SCHEMATIC

NOTES

REPLACEMENT PARTS LIST

Item	Qty.	Description	Leveler Length		
			6' Long	8' Long	10' Long
1	1	Frame Weldment	675.xxx	675.xxx	675.xxx
2	1	Platform Weldment - Safe-T-Lip	657.xxx	657.xxx	657.xxx
	1	Platform Weldment - Welded Lip	532.xxx	532.xxx	532.xxx
3	1	Safe-T-Lip Assembly Complete	687.xxx	687.xxx	687.xxx
	1	Standard Lip Weldment (Not Shown)	547.xxx	547.xxx	547.xxx
4	1	Lip Spool Module - Lip Lug Assembly (Safe-T-Lip Unit Only)	See Description Below		
		3/8" Header, 5/8"-11/16" Lip	129251	129251	129151
		3/8" Header, 3/4" Lip	129252	129252	129152
		1/2" Header, 5/8"-11/16" Lip	129253	129253	129153
		1/2" Header, 3/4" Lip	129254	129254	129154
5	2	Lip Hinge Pin 6' Wide	562.112	562.112	562.112
	2	Lip Hinge Pin 6.5' Wide	562.113	562.113	562.113
	2	Lip Hinge Pin 7' Wide	562.111	562.111	562.111
	2	Lip Hinge Pin 6' Wide (Stainless Steel)	490.105	490.105	490.105
	2	Lip Hinge Pin 6.5' Wide (Stainless Steel)	490.106	490.106	490.106
6	2	Lip Hinge Pin 7' Wide (Stainless Steel)	490.107	490.107	490.107
7	2	Tension Pin, .25Dia. x 1.75L	123960	123960	123960
7	4	Clevis Pin, Headed, .875 x 3.25L Groove ZP	129307	129307	129307
8	4	Clevis Pin, Headed, .875 x 3.25L Gr (Stainless Steel)	129309	129309	129309
8	2	Cotter Pin, .188Dia. x 1.50L ZP	51907	51907	51907
9	1	Bolt, Hex .75-10UNC x 3L ZP	51186	51186	51186
10	1	Nut, Hex .75-10UNC ZP	51517	51517	51517
11	1	Bolt Hex .5-13 UNC x 1.75L G5 ZP	58016	58016	58016
12	2	Jam Nut .5-13 UNC	51505	51505	51505
13	1	Lip Crank	121533	121533	121533
14	3	Torsion Spring 180 Deg. 1.131OD MWG	120461	120461	120461
15	3	Clevis Pin .5 x 4L HD ZP	117066	117066	117066
16	2	Lip Link	116690	116690	116690
17	1	Clevis Pin, Headed .5 Dia. 1.75L 1Hole ZP	52464	52464	52464
18	7	Cotter Pin .125 Dia. x 1L ZP	51901	51901	51901
19	11	Flat Washer .500 Flat MED ZP	51709	51709	51709
20	6	Flat Washer .375 Flat MED ZP	51700	51700	51700
21	1	Chain 7MM Gr30 LD RTG 1300Lb. ZP	512.105	512.108	512.106
22	2	Chain Shackle, 3/8	51137	51137	51137
23	1	Air Tower Assy. 120V/1Ph 3Stage	130386	130387	130387
	1	Air Tower Assy. 208-230V/1Ph 3Stage	130388	130389	130389
24	2	Round .312 Dia. x 46.5L	117070	117070	117070
25	2	Bar .25 x 1.25 x 9L Hole	116943	116943	116943
26	1	Hydrachek Bore (1DIA)	51147	51147	51147
27	1	Washer .547ID 2.25OD .25Thk ZP	121580	121580	121580
28	2	Bolt .500-13UNC 3.5L Hex ZP	111359	111359	111359
29	2	Nut .500-13UNC Nylock Jam ZP	112965	112965	112965
30	1	Clevis Pin .5 x 2.25L Hole ZP	52418	52418	52418
31	2	Safety Leg 2.56 x 3.5 x 5.88L (Casting)	129077	129077	129077
32	1	Round .5Dia. 28.25L HR M1020 (Non STO Units Only)	493.100	493.100	493.100
33	1	S-Hook .219 Wire (Welded Lip With STO Only)	51102	51102	51102
34	1	Chain Assembly Lanyard Twist #1/0 ZP	510.100	510.100	510.100
35	1	Clevis Pin .5 Dia 1.25L Hole ZP (Welded Lip Only)	117066	117066	117066
36	1	Cam MBDC .375 x 4 x 5.88 M1020 (Welded Lip Only)	116655	116655	116655
37	1	Lanyard Assy Air Tower	121042	121042	121042
38	1	4" Deep Pit Conversion Platform (DPC Only)	665.xxx	665.xxx	665.xxx
39	1	Safe-T-Strut	18722	118020	118020
40	1	Safe-T-Strut Chain Assembly	117375	117375	117375

REPLACEMENT PARTS - CONT.

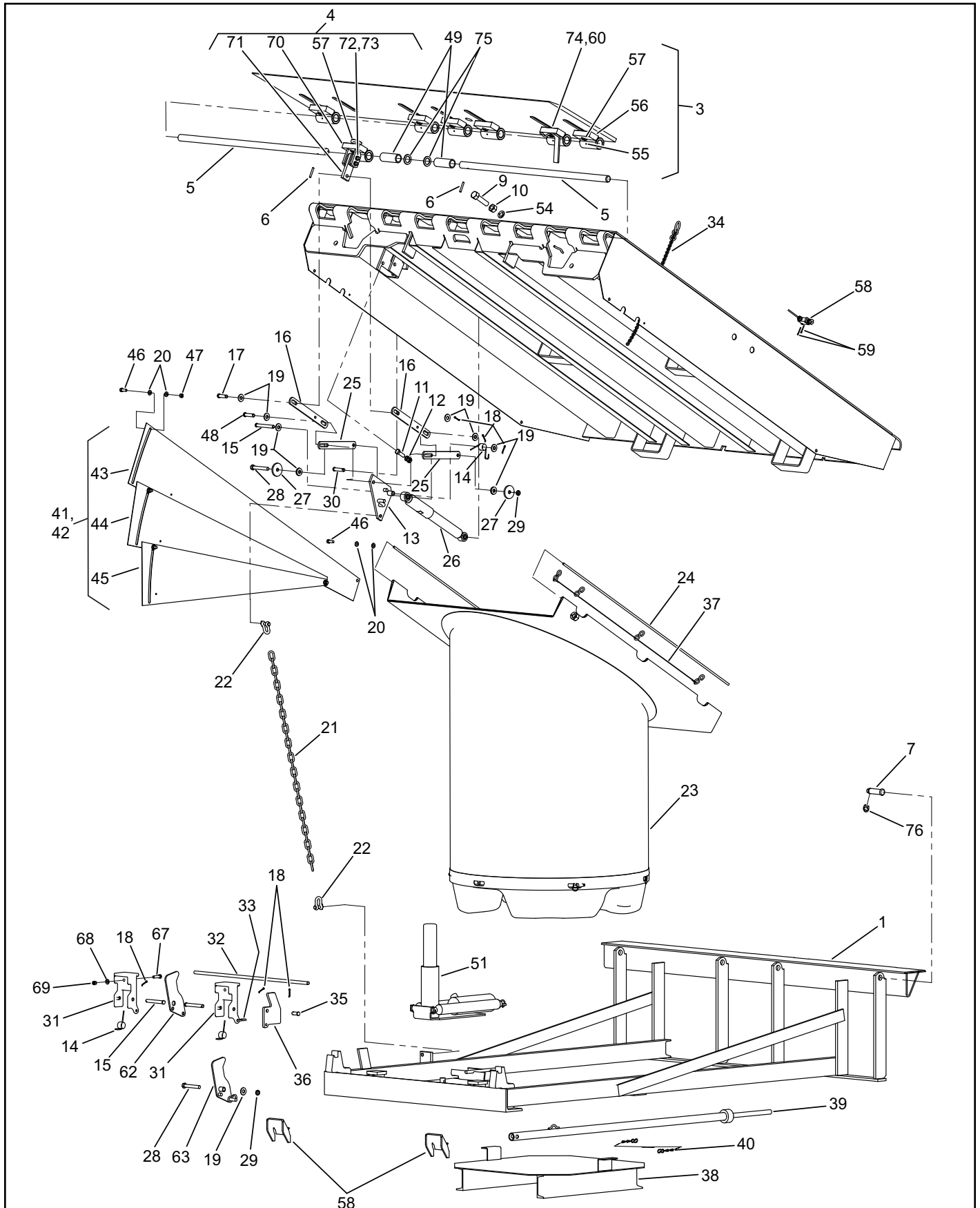

REPLACEMENT PARTS LIST

Item	Qty.	Description	Leveler Length		
			6' Long	8' Long	10' Long
41	1	Full Range LH (2 Fan) (Not Shown)	417.102	-	-
	1	Full Range LH (3 Fan)	-	419.101	419.101
42	1	Full Range RH (2 Fan) (Not Shown)	418.102	-	-
	1	Full Range RH (3 Fan) (Not Shown)	-	420.100	420.101
43	1	Toeguard Fan 14GA x 11 4Hole 1Slot LH	411.100	411.101	563.100
	1	Toeguard Fan 14GA x 11 4Hole 1Slot RH (Not Shown)	411.100	411.101	564.100
44	1	Toeguard Fan 14GA x 11 3Hole 1Slot LH	416.100	416.101	565.109
	1	Toeguard Fan 14GA x 11 3Hole 1Slot RH (Not Shown)	416.100	416.101	566.109
45	1	Toeguard Fan 14GA x 11 2Hole 1Slot LH (3 Fan Only)	-	415.107	567.106
	1	Toeguard Fan 14GA x 11 2Hole 1Slot LH (3 Fan Only)	-	415.107	568.106
46	2	Bolt Hex .375-16 x 1L G5 ZP	51600	51600	51600
47	2	Nylock Nut .38-16 UNC ZP	51501	51501	51501
48	1	Pin Clevis .5 x 2L Hole HD ZP	52409	52409	52409
49	1	Tube 1-1/2 OD x 3-7/8 Long (Safe-T-Lip Only)	477.100	477.100	477.100
50	2	Hook shpng 18/20LP Formed (Not Shown)	60902	60902	60902
51	1	Cylinder Assembly - Stump Out	117130	117130	117130
52	2	Weatherseal Insert - PT2-1 (Not Shown)	513.105	513.104	513.106
	2	Weatherseal Insert - NB1-1 (Not Shown)	514.105	514.104	514.106
53	1	Fitting Coupling Pipe(1.5Dia) 1.5NPT PVC	124860	124860	124860
54	1	Washer .75 Split LK Heavy ZP	51814	51814	51814
55	7	Grease Fitting .188Dia (Safe-T-Lip Unit Only)	51169	51169	51169
56	5	Lip Spool Module (Safe-T-Lip Unit Only)	See Descriptions Below		
		3/8" Header, 5/8"-11/16" Lip	129222	129222	129222
		3/8" Header, 3/4" Lip	129223	129223	129223
		1/2" Header, 5/8"-11/16" Lip	129224	129224	129224
		1/2" Header, 3/4" Lip	129225	129225	129225
57	7	Shoulder Bolt - 1.125 DIA. (Safe-T-Lip Unit Only)	129099	129099	129099
58	1	Limit Switch Assembly (ARTD Only)	121680	121680	121685
59	2	Screw 8-32 x 1.25L ZP (ARTD Only)	115444	115444	115444
60	1	Trigger, ARTD (Safe-T-Lip - w/ARTD - w/o Module)	129154	129154	129154
61	2	Lip Keeper Weldment Formed (Non Safe-T-Lip Units Only)	129201	129201	129201
62	1	Cam Plate MBDC .25x3.25x8L 3H (Safe-T-Lip Only)	128037	128037	128037
63	1	Cam Weldment MBDC Sprg RHA STL (Safe-T-Lip Only)	128038	128038	128038
64	1	Operational Sign (Not Shown)	128111	128111	128111
65	1	Decal Sheet Manufacturing (Not Shown)	128116	128116	128116
66	1	Decal Sheet Field (Not Shown)	128121	128121	128121
67	4	Bolt .375-16 X 1.500 Cap Hex Grade-8 ZP	68207	68207	68207
68	4	Washer Flat .38 ZP	51700	51700	51700
69	4	Nut .375-16 Nylock ZP	123810	123810	123810
70	1	Spool Module - Lip Lug (Safe-T-Lip Unit Only)	See Descriptions Below		
		3/8" Header, 5/8"-11/16" Lip	129246	129246	129246
		3/8" Header, 3/4" Lip	129247	129247	129247
		1/2" Header, 5/8"-11/16" Lip	129248	129248	129248
		1/2" Header, 3/4" Lip	129249	129249	129249
71	1	Lip Lug Weldment (Safe-T-Lip Unit Only)	129255	129255	129255
72	2	Shoulder Bolt .375-16 x 2.88L (Safe-T-Lip Unit Only)	129258	129258	129258
73	2	Whiz Nut .375-16 (Safe-T-Lip Unit Only)	51564	51564	51564
74	1	Lip Spool Module - Anchor (Safe-T-Lip w/o ARTD)	See Descriptions Below		
		3/8" Header, 5/8"-11/16" Lip	129259	129259	129259
		3/8" Header, 3/4" Lip	129260	129260	129260
		1/2" Header, 5/8"-11/16" Lip	129261	129261	129261
		1/2" Header, 3/4" Lip	129262	129262	129262
75	2	Washer Flat 1.125 ID 1.750 OD .1406Thk ZP	139809	139809	139809
76	4	Ring, Ext. Retaining, .875OD	129308	129308	129308

NOTE: Lip Spool Module part numbers above apply to most levelers. If you are not sure, contact Rite-Hite before ordering.

TYPE 1 CONTROL BOX PARTS

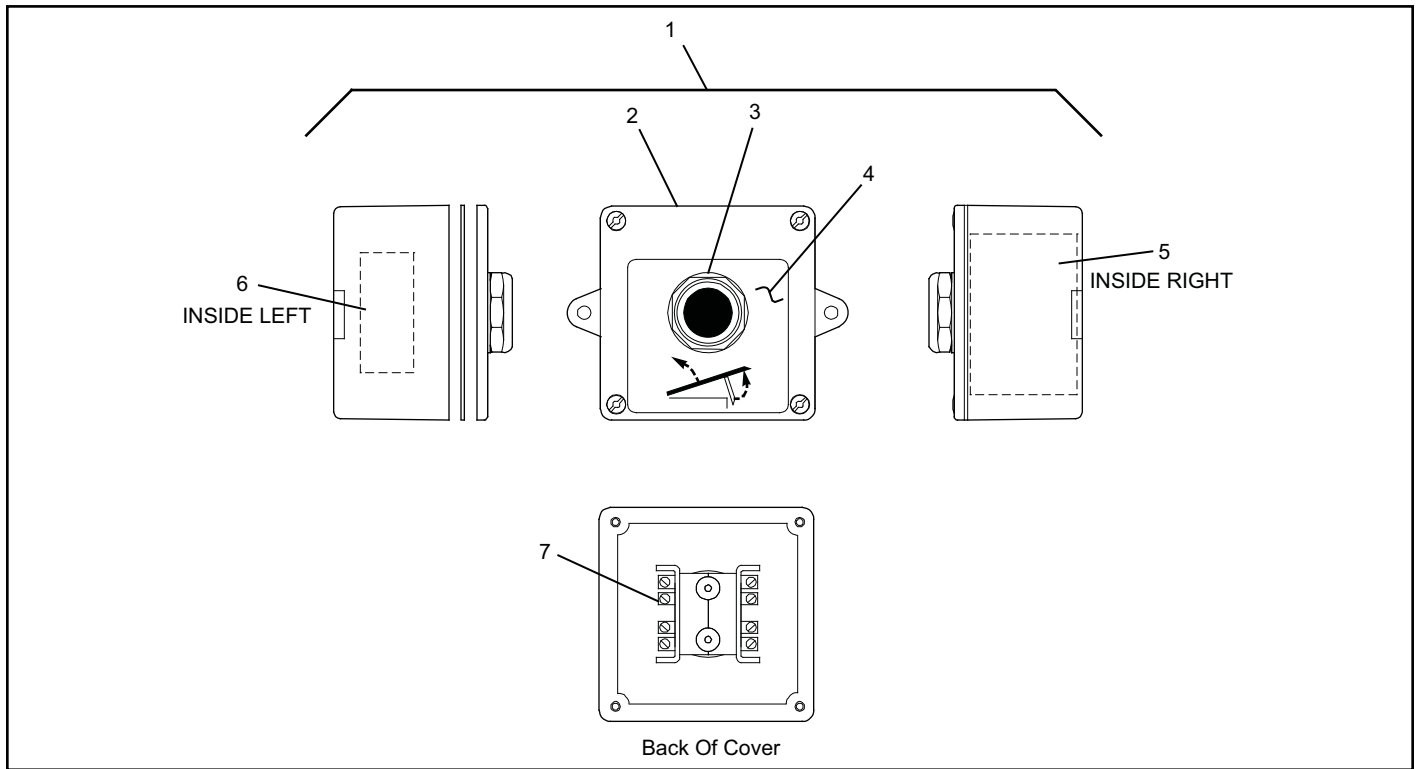

Item	Qty.	Description	Part Number
1	1	Control Box Complete	228.xxx
2	1	Control Box Enclosure, 4 x 4 x 2 N4XF	117342
3	1	Push Button Operator (30.5MM) Black, NO, N12/N4 (AB: 800T-A2D1M)	117352
	1	Push Button Operator (30.5MM) Black, NO, N4X (AB: 800H-AR2D1M)	117315
4	1	Control Box Cover Decal, Raise 3 x 3 Hole (30.5MM Oprtr)	117414
5	1	Decal V/PH/FLA	230.xxx
6	1	Decal UL/ULC - Consult RITE-HITE	-
7	1	Contact Block, NO 30.5MM 600V 10A	57077

TYPE 2 CONTROL BOX PARTS

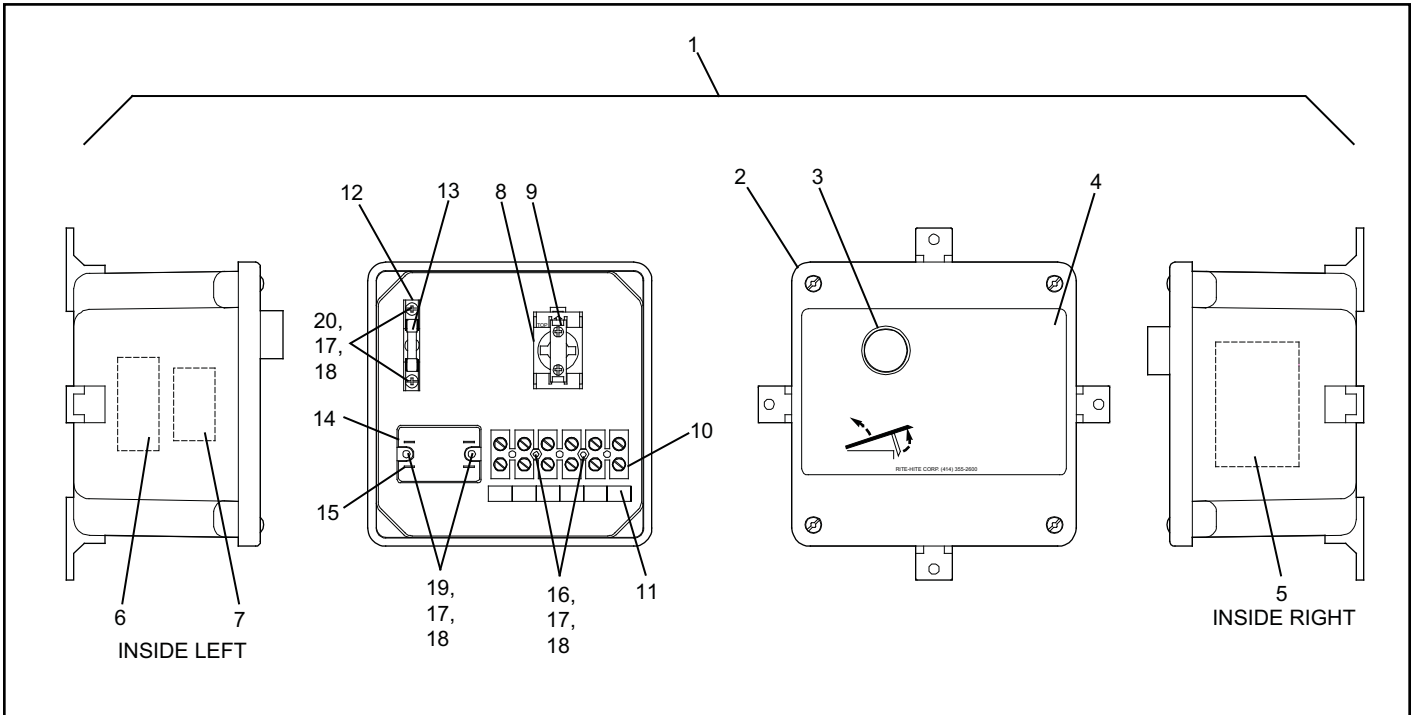

Item	Qty.	Description	Part Number
1	1	Control Box Complete	219.xxx
2	1	Control Box Enclosure, 6 x 6 x 4 N4XF	117346
3	1	Push Button Operator (22.5MM) Black, NO, N12/N4	124898
	1	Push Button Operator (22.5MM) Black, NO, N4X	124899
4	1	Control Box Cover Decal, Raise, 4 x 6, 1 Hole (22.5MM Oprtr)	117405
5	1	Decal V/PH/FLA	226.xxx
6	1	Decal UL/UCL - Consult RITE-HITE	-
7	1	Decal, Fuse Replacement	114307
8	1	Mounting Latch, 3 Across	124889
9	1	Contact Block, 1 N.O. (22.5MM)	124885
10	1	Terminal Strip Assm., 6PT, 8-14AWG	117349
11	1	Decal Terminal Strip, 6PT 115/1PH	117353
	1	Decal Terminal Strip, 6PT 230/1PH	117360
12	1	Fuse Holder, 1 Pole	65161
13	1	Fuse 1A 250V 3AG	57428
14	1	Relay, 1P INP (120VAC)	117350
	1	Relay, 1P INP (240VAC)	117351
15	1	10-12AWG Female Terminal Insulating Wire Crimp	117750
16	2	Screw #6-32 x 1, Cap Flat CTSK SLTD ZP	117354
17	6	Nut #6-32, Hex ZP	117361
18	6	Lock Washer #6 Lock Washer, Ext. Tooth ZP	103218
19	2	Screw #6-32 x .6, Cap Flat CTSK SLTD ZP	117355
20	2	Screw #6-32 x .4375, Cap Flat CTSK SLTD ZP	117344

TYPE 3 CONTROL BOX PARTS

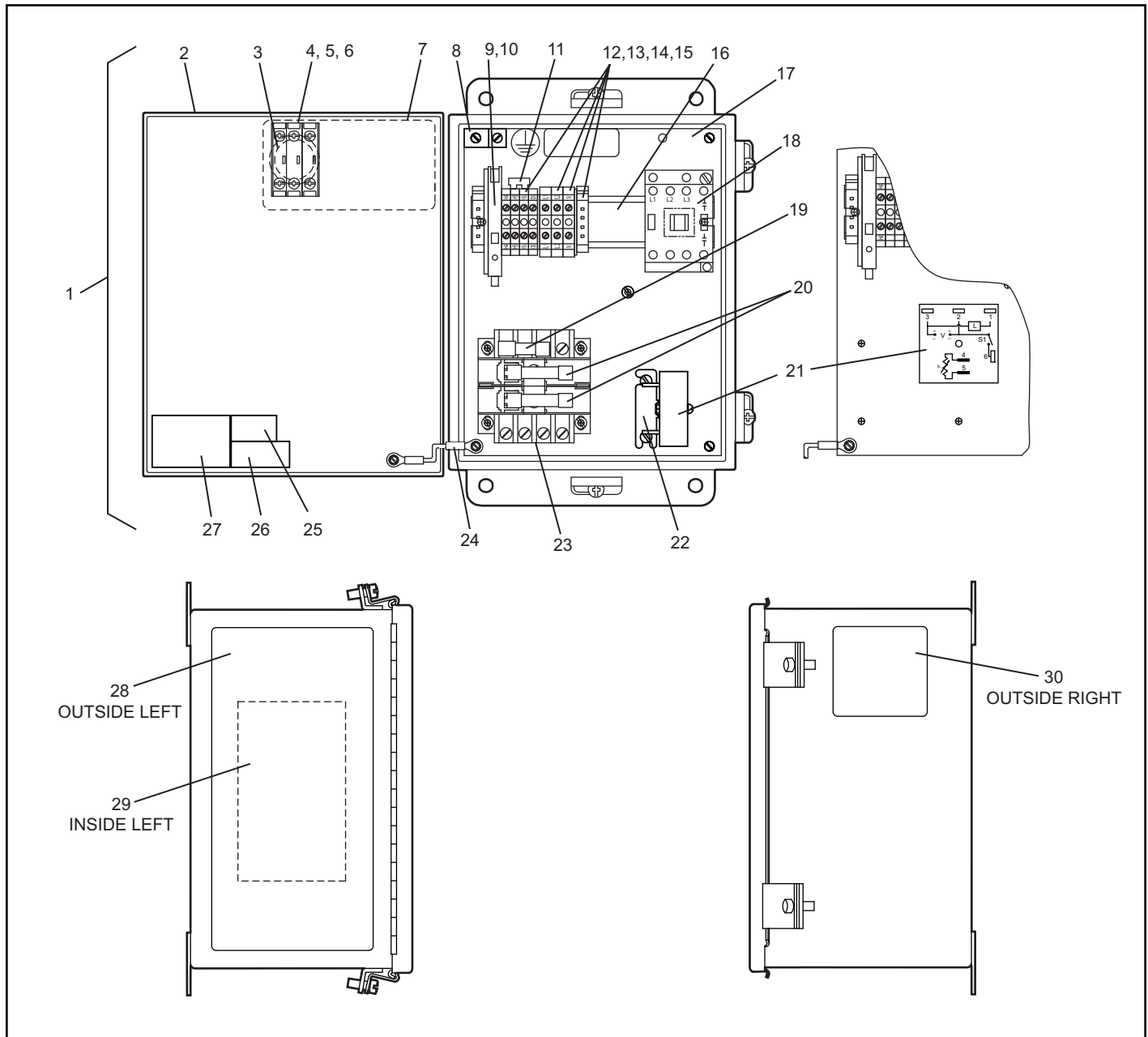

TYPE 3 CONTROL BOX REPLACEMENT PARTS LIST

Item	Qty.	Description	Part Number
1	1	Control Box Complete	219.xxx
2	1	Control Box Enclosure, 10 x 8 x 6 N12	187.107
	1	Control Box Enclosure, 10 x 8 x 6 N4	187.110
	1	Control Box Enclosure, 14 x 12 x 8 N4X (Not Shown)	187.118
3	1	Push Button Operator (22.5MM) Black, N12/N4	124898
	1	Push Button Operator (22.5MM) Black, N4X	124899
4	1	Contact Block Mounting Latch	124889
5	1	Contact Block, Black, NO	124885
6	2	Contact Block, Black, NC	124881
7	1	Cover Decal	116390
8	1	Ground Lug	55902
9	1	Fuse Holder	57275
10	1	1A Fuse, 250V Slo-Blow, (Installed Without Transformer)	57428
11	1	Terminal Jumper	65769
12	4	Red Terminal Block	65606
13	2	Black Terminal Block, 600V, 50A (1L1/ 1L2)	65666
14	1	White Terminal Block, 600V, 50A (N)	114446
15	2	End Anchor Terminal Block	66067
16	1	Mounting Din Rail	109341
17	1	Back Panel, Drilled, 10 x 8	114363
	1	Back Panel, Drilled, 14 x 12	114366
18	1	Leveler Motor Contactor	65910
19	1	Leveler Control Fuse, 1A 250V Dual Elm., 230/1/50	115479
20	2	Transformer Primary Fuse, 1A CC Rej. Dual Elm., 230/1/50	66003
21	1	Single Shot Time, ARTD	117752
22	1	Timer Mounting Bracket	115270
23	1	Transformer, 50VA 240/480V	18736
24	1	Ground Harness	114338
25	1	Decal Fuse Replacement, 115/230/1/60	114307
	1	Decal Fuse Replacement, 230/1/50	114308
26	1	Decal UL/ULC - Consult Rite-Hite	-
27	1	Decal Voltage/Phase/FLA	226.xxx
28	1	Decal Operation	102233
29	1	Decal Electrical Schematic	225.xxx
30	1	Decal Lockout/Tagout	114331

SAFE-T-LIP (1-5-1) ASSEMBLY PARTS

PRIOR TO SERIAL NUMBER 11GD400214M

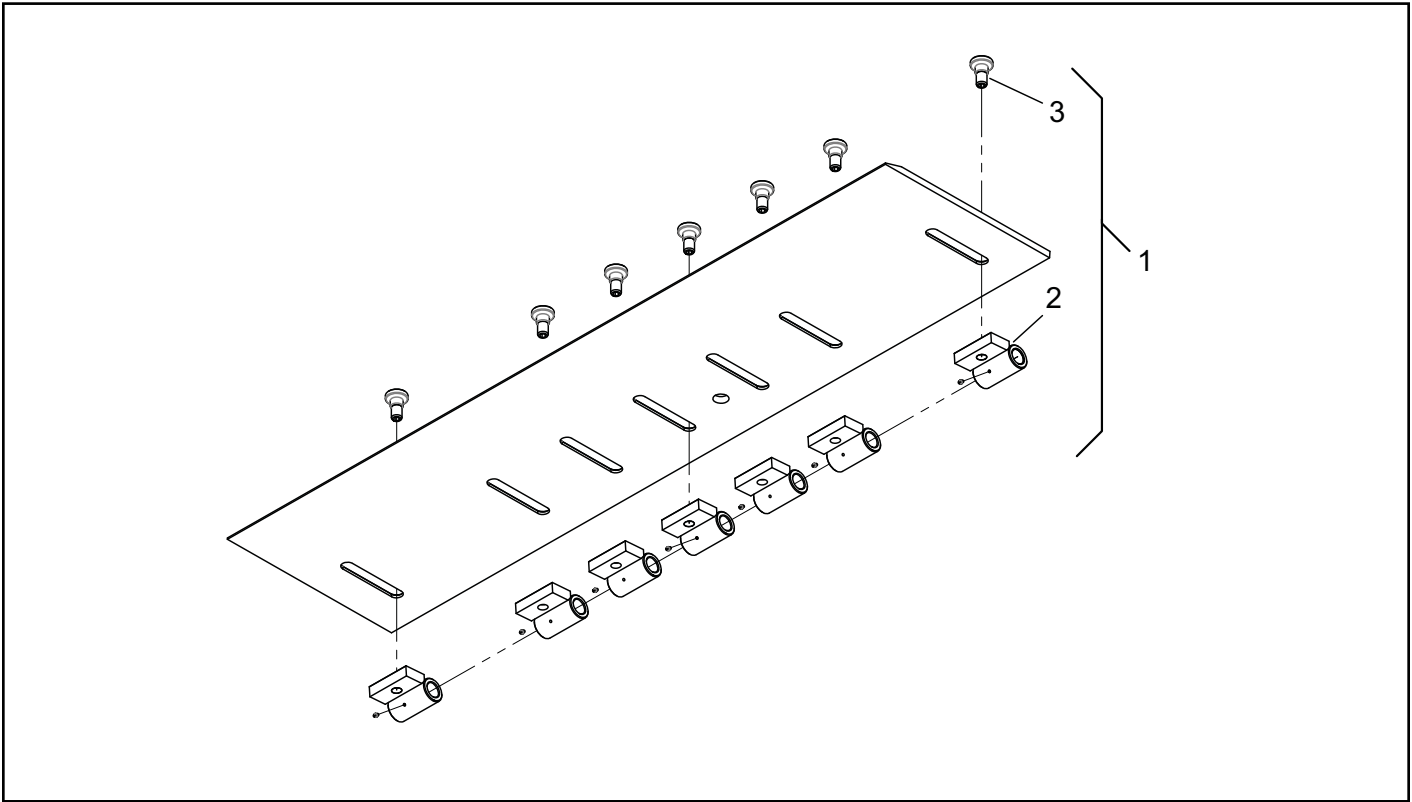

Item	Qty.	Description	Part Number
1	1	Safe-T-Lip Assembly	396.xxx
2	7	Spool Module	Consult Factory
3	7	Shoulder Bolt 1" Dia. x .66L	119920

NOTES

NOTES

NOTES

RITE-HITE® STANDARD WARRANTY

RITE-HITE® warrants that its products will be free from defects in design, materials, and workmanship for a period of 365 days from the date of shipment. All claims for breach of this warranty must be made within 30 days after the defect is or can, with reasonable care, be detected and in no event no more than 30 days after the warranty has expired. In order to be entitled to the benefits of this warranty, the products must have been properly installed, maintained, and operated within their rated capacities and/or specified design parameters, and not otherwise abused. Periodic lubrication and adjustment is the sole responsibility of the owner. This warranty is RITE-HITE's® exclusive warranty. RITE-HITE® EXPRESSLY DISCLAIMS ALL IMPLIED WARRANTIES, INCLUDING THE IMPLIED WARRANTIES OF MERCHANTABILITY AND FITNESS. Non-standard warranties, if any, must be specified by RITE-HITE® in writing.

In the event of any defects covered by this warranty, RITE-HITE® will remedy such defects by repairing or replacing any defective equipment or parts, bearing all the costs for parts, labor, and transportation. This shall be the exclusive remedy for all claims whether based on contract, negligence, or strict liability.

LIMITATION OF LIABILITY

RITE-HITE® SHALL NOT IN ANY EVENT BE LIABLE FOR ANY LOSS OF USE OF ANY EQUIPMENT OR INCIDENTAL OR CONSEQUENTIAL DAMAGES OF ANY KIND, WHETHER FOR BREACH OF WARRANTY, NEGLIGENCE, OR STRICT LIABILITY.



Global Sales & Service Office:

**RITE-HITE®
8900 N. Arbon Drive
P.O. Box 245020
Milwaukee, Wisconsin 53224**

**Phone: 414-355-2600
1-800-456-0600
www.ritehite.com**

Representatives in all Major Cities