

4

3

DWG NO  
A7120057

SHEET  
1 OF 1

REV  
C

1

NEXT ASSEMBLY

UNIT WIDTH

MIN. 10'-4", MAX. 12'-4"

MIN. UNIT WIDTH IS BASE UNIT WIDTH + 4"  
(ADDITIONAL 1/2" REQ'D FOR BRACKETING)

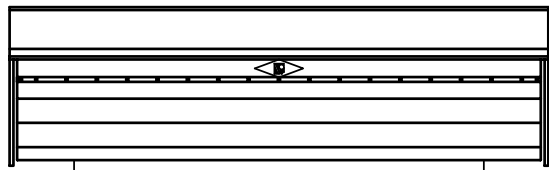

STD.  
14'-7 3/4"  
TO TOP  
OF FRONT  
BAR

STD. 15'-6 3/4"  
TO TOP OF UNIT

48"  
DOCK  
HT.

LEVEL GRADE

ELEVATION

56 1/2" MAX.  
PROJ.

SEAL DROP  
28" STD.  
(24" OPT.)

STD.  
13'-6"  
TO BOTTOM  
OF BRACKETS

4" MIN.  
BUMPER

SECTION

REVISION HISTORY

REV	DESCRIPTION	ECN	DATE	BY	APPROVED
A	CORRECTED STD./OPTIONAL SEAL DROP	--	6/18/04	GDB	
B	ADDED EXTENSION TO PIVOT ARM	08-034	10/15/08	RPW	
C	ADDED "FOR REFERENCE ONLY" NOTE	11-010	3/29/2011	GDB	

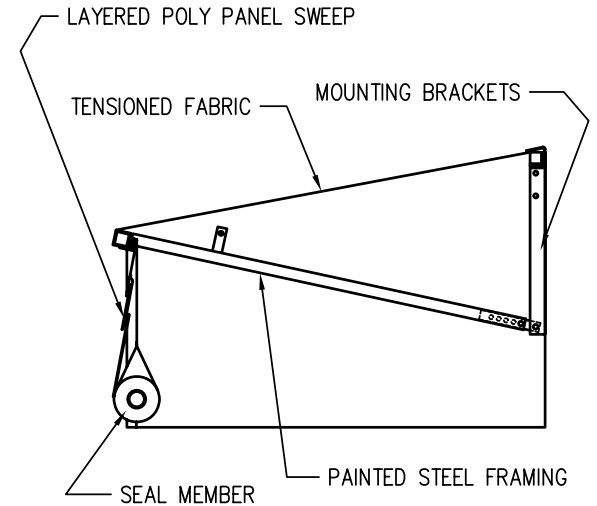

DETAIL OF SECTION VIEW

THIS DRAWING IS FOR  
REFERENCE ONLY.  
DO NOT USE FOR  
PRODUCTION  
PURPOSES.

A

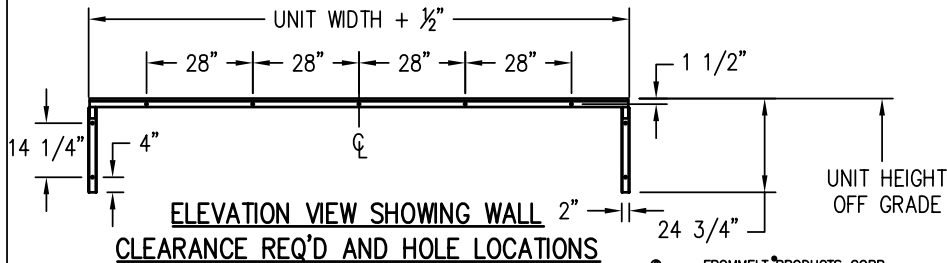

ELEVATION VIEW SHOWING WALL  
CLEARANCE REQ'D AND HOLE LOCATIONS

© FROMMELT PRODUCTS CORP.

ITEM	QTY	PART NO.	DESCRIPTION
PARTS LIST / MATERIAL			

INCH TOLERANCES			DO NOT SCALE DRAWING	
OVER	UP TO	+ / -	MM-DD-YY	
0	0.125	0.005	DRAWN BY	GDB
0.125	0.25	0.010	DATE	10/30/03
0.25	1.25	0.020	CHECKED BY	
1.25	5	0.030	DATE	
5	15	0.040	APPROVED BY	
15	40	0.060	DATE	
40	80	0.100	INITIAL ECN	04-006
80	-	0.125	DATE ISSUED	
ANGLES	±/- 1 DEG		REF	
FINISH	NONE			

<b>FROMMELT<sup>®</sup></b> <b>PRODUCTS CORP.</b>			
TITLE ARCHITECTURAL APPROVAL RG3000			
SIZE B	MODEL NUMBER RG3000	DWG NO A7120057	REV C
SCALE 3/8" = 1'	PART #	SHEET 1 OF 1	

4

3

2

1