

---

# **Dok-Lok<sup>®</sup>**

## **Vehicle Restraint Owners Manual**

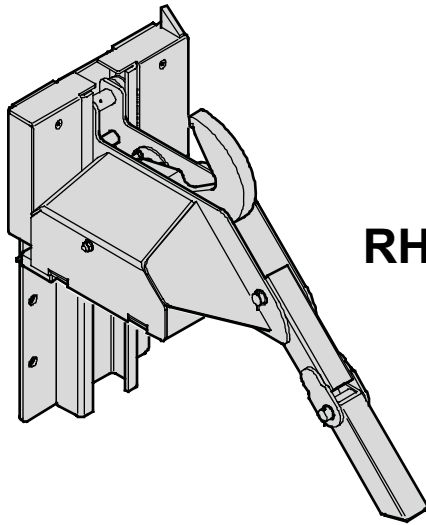

**RHR-1000 Dok-Lok<sup>®</sup>**

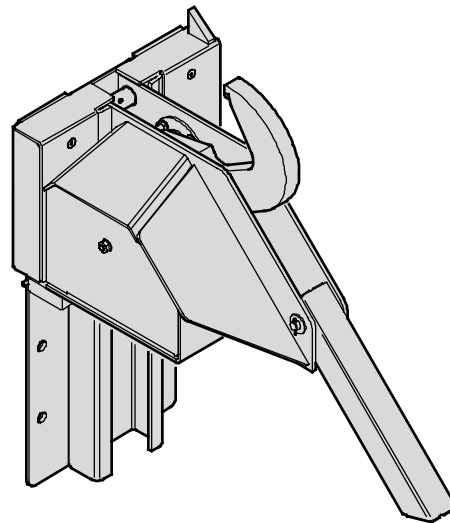

**RHR-600 Dok-Lok<sup>®</sup>**



**This Manual Covers Restraints Built After Serial Numbers:  
RHR001000 and up**

# TABLE OF CONTENTS

INTRODUCTION .....	2
OWNERS RESPONSIBILITY .....	4
DEFINITION AND FUNCTION .....	5
FEATURES .....	5
OPERATING PROCEDURE .....	7
MAINTENANCE .....	11
TROUBLESHOOTING .....	13
HORN OVERRIDE CODE AND DIAGNOSTICS (RHR-1000 MODEL ONLY) .....	16
ELECTRICAL SCHEMATIC .....	19
REPLACEMENT PARTS .....	20
WARRANTY .....	BACK COVER

## INTRODUCTION

Read and understand this manual before attempting to install or operate any DOK-LOK vehicle restraint. For best results, have this product serviced by your authorized RITE-HITE representative. The RHR DOK-LOK vehicle restraint by RITE-HITE is intended to provide a safer workplace for workers in shipping and receiving dock areas. The RHR DOK-LOK vehicle restraint is an electro-mechanical restraint device that, when properly installed and operated, retains a secure connection between the truck and dock. Signal lights, warning horn and signs provide instructions to the truck driver and DOK-LOK vehicle restraint operator that a safe condition exists. The DOK-LOK vehicle restraint is operated by pressing push buttons on an inside control panel.

## IMPORTANT

Read and understand contents of this manual prior to installation or operation of this equipment. For best results, have this product serviced by your authorized RITE-HITE® representative.

## NOTICE TO USER

Your local RITE-HITE® representative provides a Planned Maintenance Program (P.M.P.) which can be fitted to your specific operation. Call your local representative or the RITE-HITE® Corporation at 414-355-2600.

The RITE-HITE® products in this manual are covered by one or more of the following U.S. patents: 5,040,258; 5,271,183; 5,323,503; 5,375,965; 5,440,772; 5,442,825; 5,531,557; 5,546,623; 5,553,987; 5,582,498; 5,664,930; 5,702,223; 5,762,459 (RE: 37,570); 5,882,167; 5,964,572; 6,010,297; 6,052,268; 6,065,172; 6,070,283; 6,074,157; 6,085,375; 6,092,970; 6,106,212; 6,116,839; 6,190,109; 6,220,809; 6,238,163; 6,276,016; 6,311,352; 6,318,947; 6,322,310; 6,360,394; 6,368,043; 6,431,819; 6,488,464; 6,497,076; 6,499,169; 6,505,713; 6,524,053; 6,634,049; 6,654,976; 6,676,360; 6,726,432; 6,773,221; 6,832,403; 6,880,301; 6,892,411; 7,032,267; 7,062,814; 7,134,159; 7,213,285; 7,216,391; 7,363,670; 7,380,305 and pending U.S. and foreign patent applications. RITE-HITE®, LEVEL-RITE®, THINMAN™, SAFE-T-LIP®, HYDRACHEK®, WHEEL-LOK™, DOK-LOK®, DUAL-DOK®, SAFE-T-STRUT™, DOK-COMMANDER®, JUMBO™, HYDRA-RITE™, SAFE-T-GATE®, and SMOOTH TRANSITION DOK SYSTEM™, are trademarks of RITE-HITE® Corporation.

# SAFETY WARNINGS

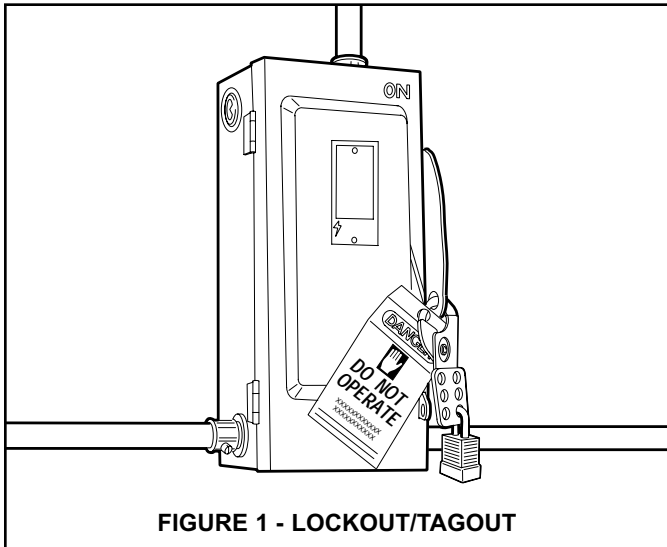

**⚠ WARNING**

When working with electrical or electronic controls, make sure that the power source has been locked out and tagged out according to OSHA regulations and approved local electrical codes.

## LOCKOUT/TAGOUT PROCEDURES

The Occupational Safety and Health Administration (OSHA) requires, in addition to posting safety warnings and barricading the work area (including, but not limited to, trucking office and loading docks), that the power supply has been locked in the OFF position or disconnected. It is mandatory that an approved lockout device is utilized. An example of a lockout device is illustrated. The proper lockout procedure requires that the person responsible for the repairs is the only person who has the ability to remove the lockout device.

In addition to the lockout device, it is also a requirement to tag the power control in a manner that will clearly note that repairs are under way and state who is responsible for the lockout condition. Tagout devices have to be constructed and printed so that exposure to weather conditions, or wet and damp locations, will not cause the tag to deteriorate or become unreadable.

RITE-HITE® does not recommend any particular lockout device, but recommends the utilization of an OSHA approved device (refer to OSHA regulation 1910.147). RITE-HITE® also recommends the review and implementation of an entire safety program for the Control of Hazardous Energy (Lockout/Tagout). These regulations are available through OSHA publication 3120.

**⚠ DANGER**

This is the highest level statement. Failure to follow the listed instructions will most likely result in severe injury or death.

**⚠ CAUTION**

The statements used with this level of warning deal with a safe operating procedure. If the procedure is ignored the possibility of personal injury may exist.

**⚠ WARNING**

This is a statement of serious hazard. Failure to follow the listed instructions could place the individual at risk of serious injury or death.

**IMPORTANT**

IMPORTANT is used to draw attention to a procedure that needs to be followed to prevent machine damage.

## OWNER RESPONSIBILITY

1. The owner should recognize the inherent danger of the interface between dock and transport vehicle. The owner should, therefore, train and instruct operators in the safe use of dock equipment in accordance with the information provided below. The manufacturer shall publish, provide to the initial purchaser, and make the following information readily available to owners:
  - Installation instructions
  - Recommended initial and periodic inspections procedures
  - Maintenance procedures
  - Operating instructions
  - Descriptions or specifications for replaceable or repairable parts
  - Tables identifying the grade (slope) for all variations of length or configuration of the dock equipment, and
  - Information identifying the maximum uncontrolled drop encountered upon sudden removal of support while within the working range of the equipment.

It shall be the responsibility of the owner to verify that the material listed in this section has been received and that it is made available for the instruction and training of personnel entrusted with the use or maintenance of the dock equipment.
2. When a transport vehicle is parked at a loading dock, it is important that the vehicle is relatively perpendicular to the dock face and in close contact with at least one of the dock bumpers.
3. Nameplates, cautions, instructions, and posted warnings shall not be obscured from the view of operating or maintenance personnel for whom such warnings are intended.
4. Manufacturer's recommended periodic maintenance and inspection procedures in effect at date of shipment shall be followed, and written records of the performance of these procedures should be kept.
5. As with any piece of machinery, dock equipment requires routine maintenance, lubrication, and adjustments. Your local RITE-HITE® representative offers owners the option of a Planned Maintenance Program (P.M.P.). As part of this service, your local RITE-HITE® representative will do all routine maintenance, lubrication, and adjustments.
6. Dock equipment that is structurally damaged shall be removed from service, inspected by a manufacturer's authorized representative, and repaired as needed before being placed back in service.
7. The manufacturer shall make available replacement nameplates, caution/instruction labels, and operating/maintenance manuals upon request of the owner. The owner shall see that all nameplates, caution/instruction markings or labels are in place and legible, and that the appropriate operating/maintenance manuals are provided to users.
8. Modifications or alterations of dock equipment shall be made only with written permission of the original manufacturer. These changes shall also satisfy all safety recommendations of the original equipment manufacturer for the particular application of the dock equipment.
9. In order to be entitled to the benefits of the standard product warranty, the dock equipment must have been properly installed, maintained and operated within its rated capacities and/or specific design parameters, and not otherwise abused.
10. It is recommended that trailers equipped with air ride suspensions should remove the air from the suspension to minimize trailer bed drop, prior to loading or unloading.
11. When industrial trucks are driven on and off transport vehicles during the loading and unloading operation, the brakes on the transport vehicle shall be applied and wheel chocks or a positive restraining device shall be engaged.
12. In selecting dock equipment, it is important to consider not only present requirements but also future plans or adverse environments.

## DEFINITION AND FUNCTION

The RHR DOK-LOK vehicle restraint is an electromechanical, self-aligning restraint device used to secure trucks and semi-trailers with an intact Rear Impact Guard (R.I.G.) to the face of a loading dock. This is achieved by hooking the R.I.G. with an electrically powered steel hook. This prevents forward movement of the truck/trailer that may create an unsafe void between the face of the dock and the rear end of the truck/trailer as a forklift travels from the loading dock onto the trailer; or to create an obstruction noticeable to the truck driver, should the driver accidentally try to pull the truck/trailer away while it is being serviced.

The proper or improper activation of the hook is monitored by:

### • VISUAL CONTROL

— One set of flashing green or red lights located at the inside of the building for the forklift operator, and one set located outside of the building for the truck driver. In addition to the lights, there are three instruction signs.

### • AUDIO CONTROL

— A horn will sound at the inside of the building, warning the forklift operator if there is no R.I.G. present, or if the engagement is improper. In this case, the trailer must be secured by other means (wheel chocks, etc.) prior to servicing trailer.

Prerequisite for proper hook engagement is that the trailer is parked firmly against a 4" (trade standard) thick dock bumper. The activation/deactivation is solely controlled from the inside of the building by momentarily depressing either the LOCK (raise) button or the Unlock (lower) button.

The normal mode of the hook is in the lower stored position, showing a flashing red light (trailer not secured) at the inside of the building and a flashing green light (trailer free to move to or away from the loading dock) at the outside of the building.

Once the trailer is parked, the dock attendant will depress the LOCK button. This will raise the hook to engage the R.I.G. As soon as the R.I.G. is properly locked, there will be simultaneous light change — the inside will change from red to green flashing (trailer secured) and the outside will change from green to red flashing (do not move trailer). After the service is completed, the dock attendant will have to depress the Unlock button which then will return the hook to its lower stored position.

A proper hook engagement is achieved when the hook raises unobstructed to fully trap the horizontal cross member of the R.I.G. Assembly. An improper hook engagement is if the horizontal cross member of the R.I.G. is missing, obstructed, or it is bent or located so far toward the rear axle of the trailer that it will prevent the free passage of the hook. In either case, the lights will stay in a non-serviceable mode and a horn will sound. At this point, the trailer must be secured by other means (example: wheel chocks) in order to become serviceable.

## FEATURES

Refer to Figure 2, page 6 for locations of these features:

### R.I.G.

Acronym used for the Federally mandated rear impact guard located on the rear of over the road trailers to prevent accidental underride by automobiles.

### ROLLER TRACK ASSEMBLY

Mounted to the loading dock wall to guide the carriage assembly in a vertical plane and transmit the creep or pull out force from a trailer to the loading dock wall.

### CARRIAGE ROLLER ASSEMBLY

Comprised of a steel roller housing, a pre-lubricated needle bearing to allow easy movement of the carriage assembly.

### CARRIAGE RETURN SPRINGS

Bias the carriage assembly to its upward stored position and to maintain contact with the R.I.G. while servicing a trailer.

### LOWER SPRING BAR

Provides a connection between the carriage assembly and roller track assembly using carriage return springs.

### CARRIAGE ASSEMBLY

Sloped front provides self-positioning by the R.I.G. and restrains the trailer once the hook has been activated by the dock attendant.

### CARRIAGE ASSEMBLY SLOPE EXTENSION

Allows trailers with lower R.I.G.s to be serviced by the DOK-LOK vehicle restraint.

### HOOK

Entraps R.I.G. to prevent trailer from rolling/creeping away from the dock.

### MOTOR ASSEMBLY

Provides means of moving the hook between its stored and active positions.

### SPRING COVERS WITH LIP GUIDE

Protect the springs and keep debris out of the roller track assembly. Right hand cover has an integral lip guide which is used to guide the lip past the roller track assembly in a below dock end load condition.

### LIMIT SWITCHES, CONTROL HARNESS, CONTROL BOX, OUTSIDE LIGHT BOX, AND SIGNAGE

Combination of these components is used to control the RHR DOK-LOK vehicle restraint and provide audio/ visual communications to the dock attendant and trailer driver.

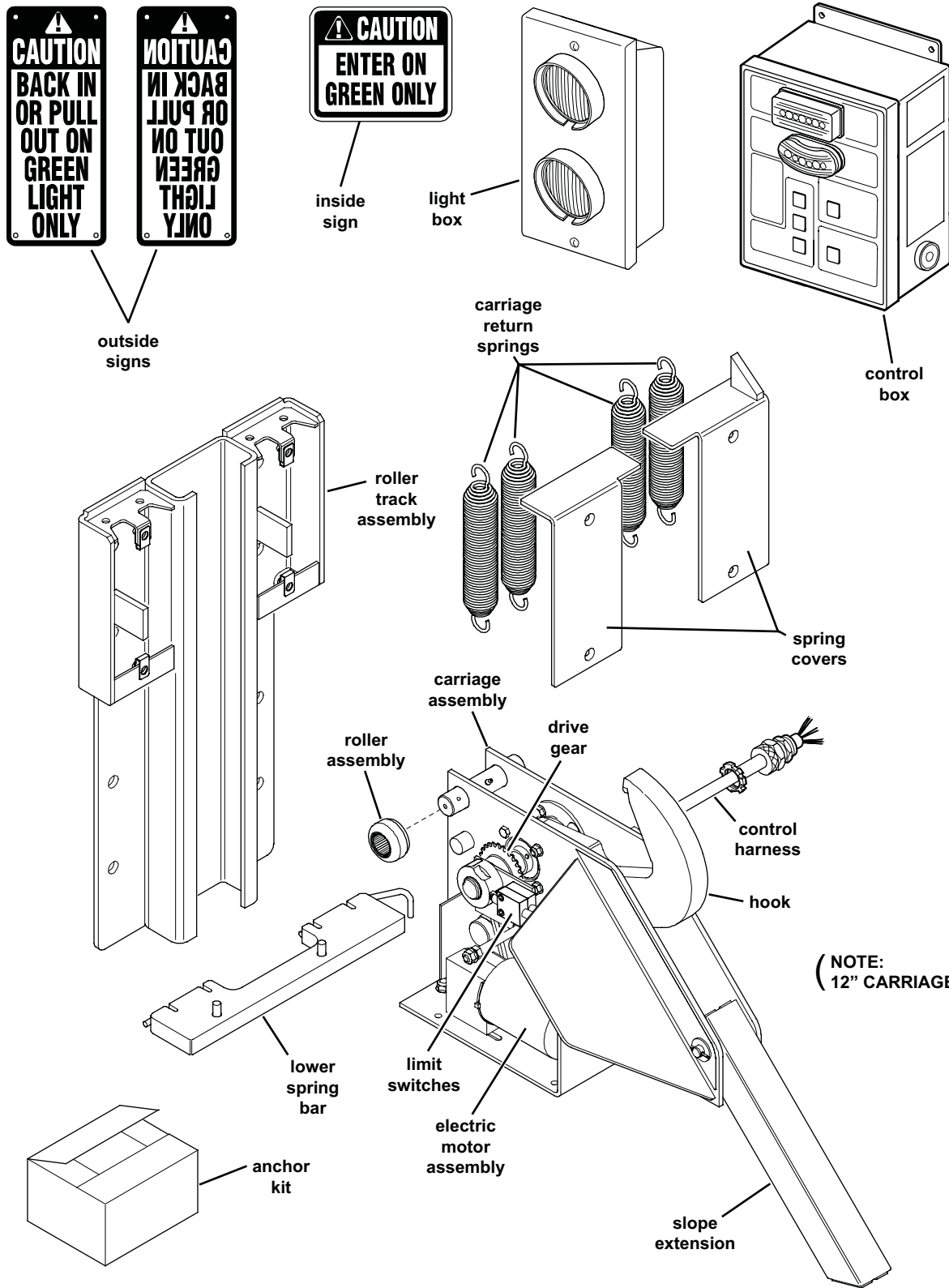

FIGURE 2 - RHR DOK-LOK VEHICLE RESTRAINT FEATURES

# OPERATING PROCEDURE

## ⚠ WARNING

- Before loading or unloading a vehicle at your loading dock while using a DOK-LOK vehicle restraint, always visually inspect to be sure that the barrier blocks the R.I.G. assembly. If a condition occurs that cannot be remedied by backing the trailer firmly against the dock bumpers, secure the trailer by other means.
- Be sure that the area around the R.I.G. assembly is free of plates or other obstructions.
- Always operate the DOK-LOK vehicle restraint from the top of the dock.
- Inspect all restraint lights daily to make certain they work properly.
- Perform maintenance on restraints in accordance with Maintenance on page 11 of this manual.
- DOK-LOK vehicle restraints should be operated only by authorized personnel who have read and understand the Owner's Manual.
- Call your local representative or RITE-HITE at (800) 456-0600 with any questions.

**FAILURE TO FOLLOW THESE PROCEDURES COULD ALLOW UNEXPECTED TRAILER / LOADING DOCK SEPERATION RESULTING IN DEATH OR SERIOUS INJURY!**

### Stored Position / Restraint UNLOCKED

Hook is in the STORED position. Inside light is flashing red alerting forklift operator unsafe condition exists. Outside light is flashing green alerting truck driver it is safe to back in.

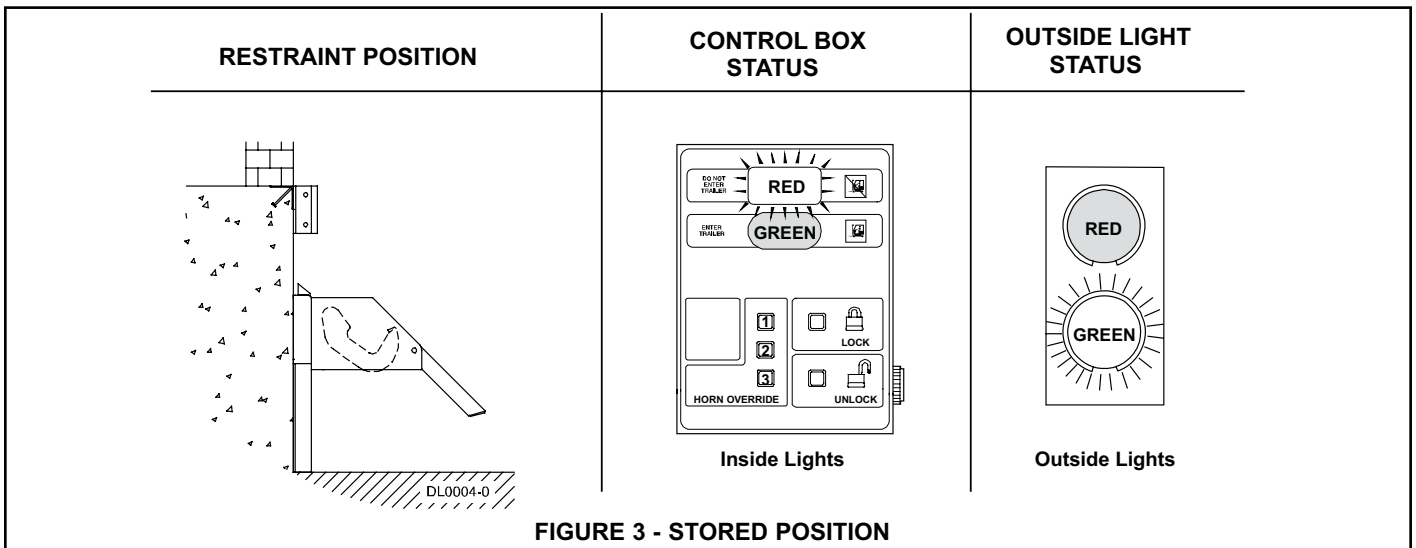

### Restraint Locking, LOCK Button Pressed

Trailer has backed into loading dock and is parked firmly against dock bumpers. Hook rotates from stored position to entrap R.I.G. Inside light is steady red alerting the operator that an unsafe condition exists and hook is in transit. Outside light is flashing red alerting truck driver not to move.

If horn sounds, go to FAULT, otherwise go to Restraint LOCKED.

 <b>CAUTION</b>
<p>If trailer can not be restrained due to a lift gate or other obstruction that could become damaged, go to <b>VERRIDE</b> state.</p>

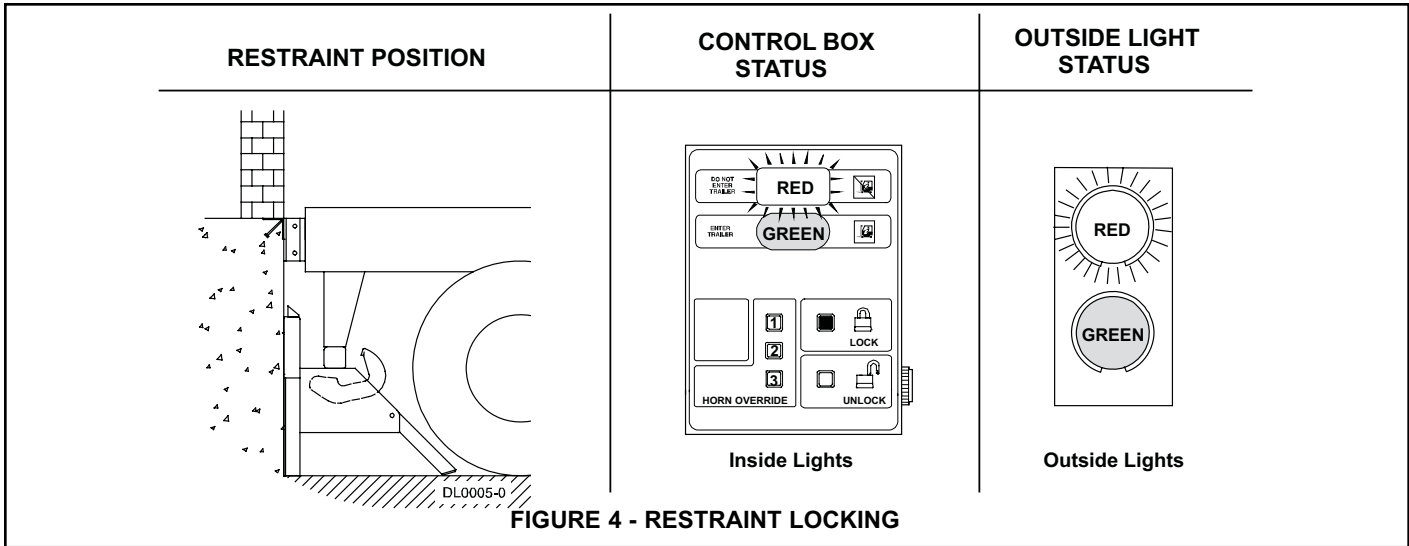

### Restraint LOCKED

Once the R.I.G. is entrapped by the hook, a LOCKED condition exists. Inside light is flashing green alerting the forklift operator a safe condition exists. Outside light is flashing red alerting truck driver not to move.

If during loading/unloading the inside light turns red and the horn sounds, press LOCK button to secure the R.I.G.

 <b>WARNING</b>
<p>Visually inspect to ensure that the <b>DOK-LOK</b> vehicle restraint hook securely entraps the R.I.G. of the trailer being serviced before operating the dock leveler.</p>

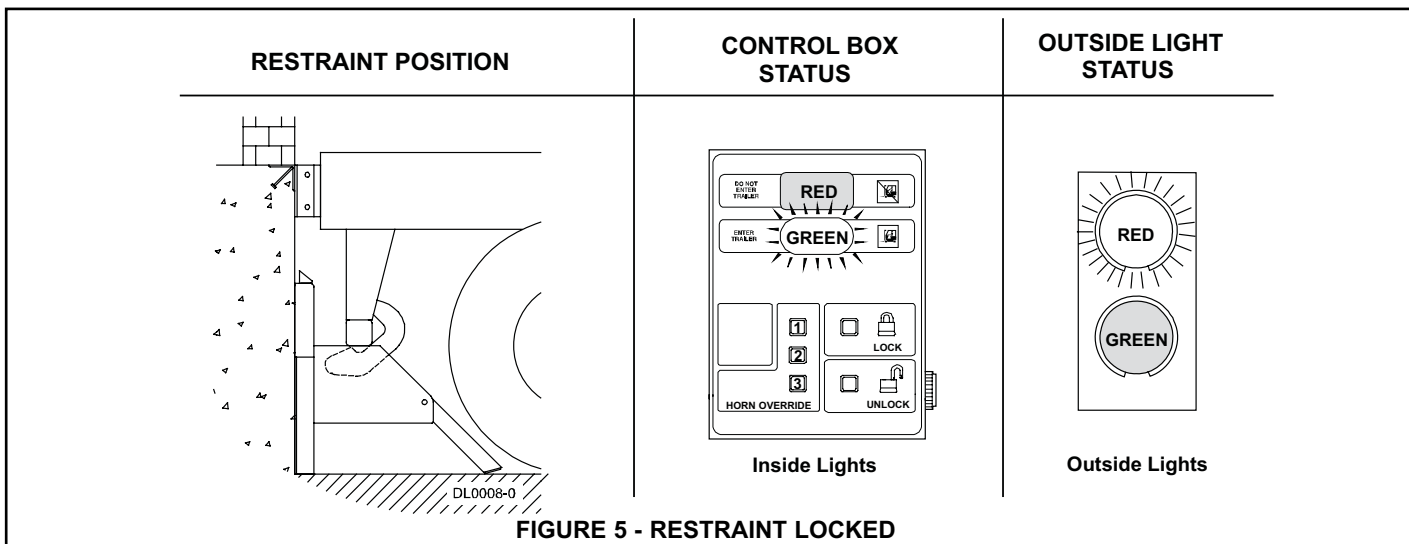

### Restraint UNLOCKING, UNLOCK Button Pressed

Hook travels from the LOCKED position to the STORED position. Inside light is steady red alerting the operator that an unsafe condition exists and hook is in transit. Outside light is flashing red alerting truck driver not to move. If horn sounds go to FAULT state, otherwise go to STORED.

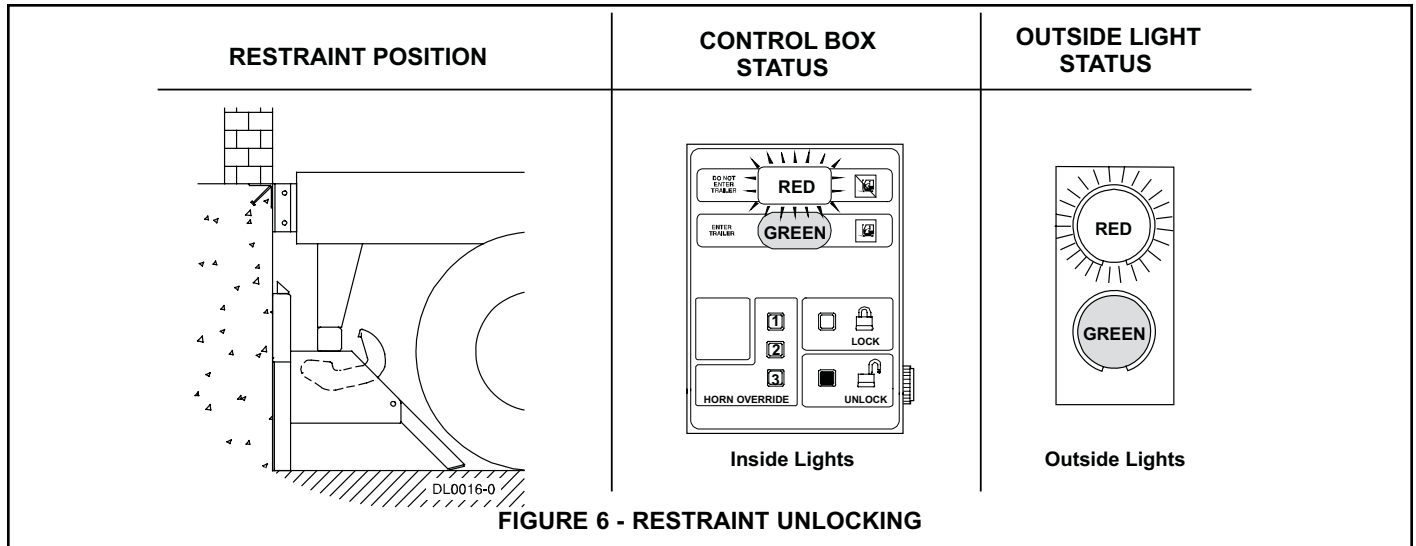

### FAULT State From LOCKING State

Hook cannot entrap the R.I.G. This could be due to a R.I.G. that is located too far toward the rear axle, bent, obstructed or missing. Inside light is flashing red and horn is pulsing, alerting the forklift operator that the trailer is not locked. Outside light is flashing red alerting the truck driver not to move.

### FAULT State From UNLOCKING State

Hook cannot rotate to the STORED position. The hook could be caught on the R.I.G. or another part of the trailer. Inside light is flashing red and horn is pulsing, alerting the forklift operator that the trailer is not locked. Outside light is flashing red alerting the truck driver not to move.

If the trailer is parked firmly against the dock bumpers go to HORN OVERRIDE state. If not, press UNLOCK to clear the fault, have trailer back up and repeat Restraint LOCKING.

Make sure trailer is parked firmly against the dock bumpers. If not, press LOCK to entrap R.I.G., have trailer back up and repeat Restraint UNLOCKING.

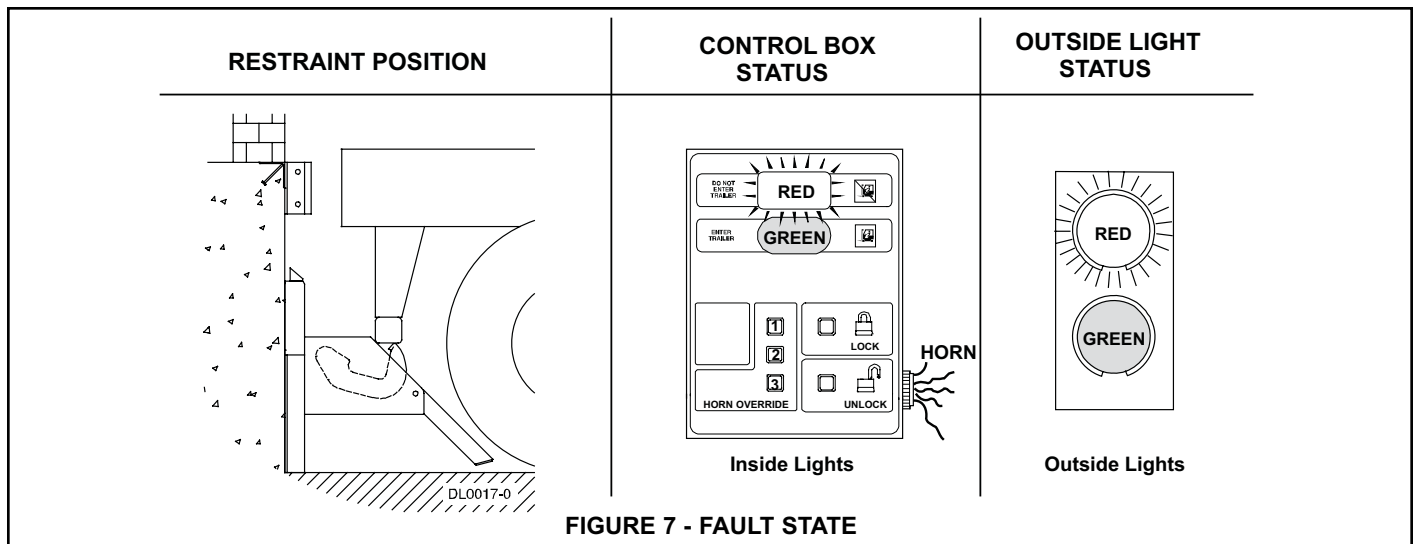

**HORN OVERRIDE State, HORN OVERRIDE Code Entered or HORN OVERRIDE Button Pressed after Securing Trailer by Alternate Means**

An alternate means of securing the truck must be used if the hook can not capture the rear impact guard.(i.e. wheel chocks). Inside lights are flashing red and green alerting the forklift operator the trailer is secured by other means. Outside light is flashing red alerting the truck driver not to move.

To return to STORED, enter HORN OVERRIDE Code or press the HORN OVERRIDE button followed by the UNLOCK button.

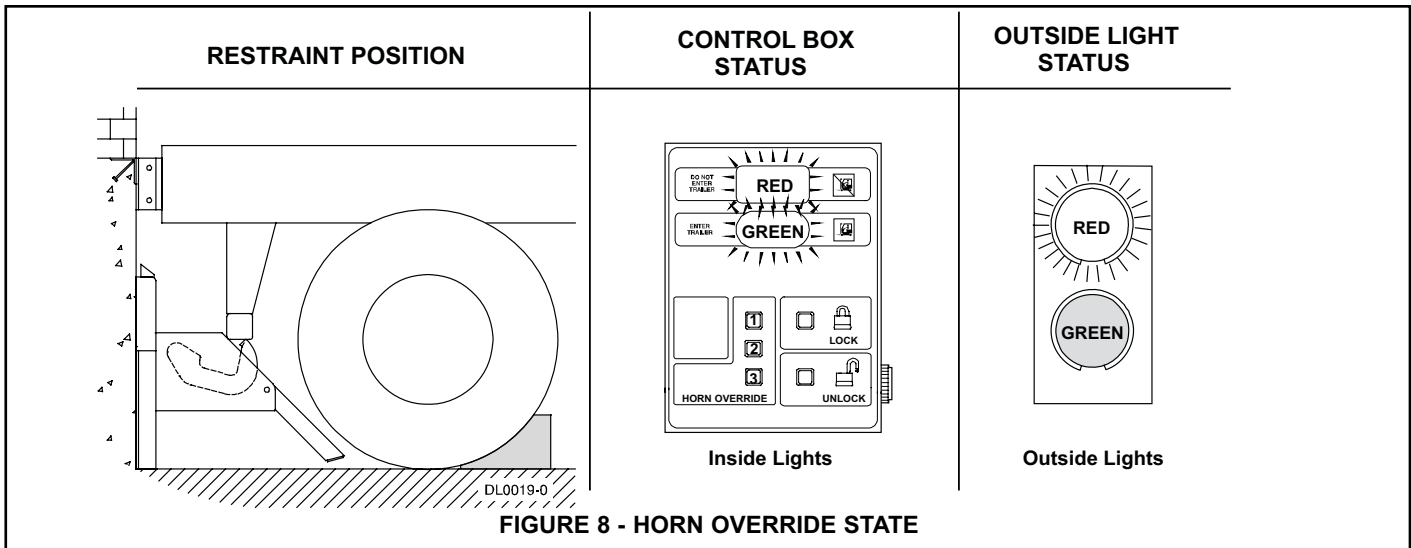

**⚠ DANGER**

When working with electrical or electronic controls, make sure that the power source has been locked out and tagged according to OSHA regulations and approved local electrical codes.

**⚠ DANGER**

Post safety warnings and barricade work area, at dock level and at ground level, to prevent unauthorized use of the dock position.

**⚠ WARNING**

A safe work place requires all lights and the horn to be working properly. DO NOT use DOK-LOK vehicle restraint if parts are broken or missing.

**⚠ CAUTION**

When lifting carriage (approx. 110 lbs.) use lifting device (ex. crane, jack). Lifting by hand may cause back injury.

**IMPORTANT**

Maintenance may be required more frequently at loading docks exposed to harsh environments (extreme climates, corrosive chemicals, frequency of usage, etc.). Consult RITE-HITE if these conditions exist for accelerated maintenance requirements.

**NOTE:** If a leveler is installed at the RHR DOK-LOK vehicle restraint location, it may be necessary to raise the leveler before performing maintenance. Raise the leveler, insert and secure the SAFE-T-STRUT, and LOCKOUT/TAGOUT the power source.

**NOTE:** Your local RITE-HITE® representative provides a Planned Maintenance Program (P.M.P.) which can be fitted to your specific operation. Call your local representative.

**DAILY**

1. Remove debris around DOK-LOK vehicle restraint.
2. Verify inside, outside lights and horn are working.
3. Replace damaged or missing light bulbs and lenses.
4. Repair, remount, or replace outside and inside signs as required.
5. Inspect dock bumpers. Missing bumpers must be replaced.

**180 DAYS**

1. Perform all Daily maintenance.
2. Grease rollers at fittings located on the top and bottom axle. Use Mobilith SHC220 No. 2 grease (or equivalent temperature range lithium based grease). Seven (7) to eight (8) pumps should be used for first 180 Day maintenance. Two (2) to three (3) pumps at subsequent 180 Day maintenance intervals.
3. Verify clutch torque is greater than 500 in-lbs at the hook shaft.
4. Inspect outside junction and light box. They should be rigidly mounted. If loose or damaged, inspect all wires and wire connections.
5. Check that all concrete anchor bolts are torqued to 100 ft-lbs.
6. Inspect flexible electrical harness from DOK-LOK vehicle restraint to junction box. Look for kinks, crushed areas, etc.
7. Perform operational test after all maintenance repairs and adjustments are complete.
8. Inspect dock bumpers. Four inches (4") of protection is required. Worn, torn, loose or missing bumpers must be replaced.

**360 DAYS**

1. Perform all Daily and 180 Day maintenance.
2. Check and tighten, if necessary, motor drive chain. To tighten see Figure 9, page 12.
3. Spray lube chain using spray grease (Zep 2000 recommended).
4. Lubricate (Zep 2000) limit switch mounting bracket between drive sprocket and cam.

## DRIVE CHAIN ADJUSTMENT

### DANGER

When working with electrical or electronic controls, make sure that the power source has been locked out and tagged according to OSHA regulations and approved local electrical codes.

Periodically inspect the drive chain for dirt and chain slack. Open the motor enclosure for inspection. Clean the chain with solvent. After cleaning, spray the chain with a good quality chain spray type lubricant.

The drive chain should not have more than 1/4" slack. Refer to Figure 9. To tighten chain:

1. Open motor enclosure and loosen the four (4) motor mounting bolts.
2. Pry the motor assembly forward, in the slotted holes, until the chain is tight with proper alignment between sprockets. Hold in this position and tighten the four (4) motor mounting bolts to 105 in-lbs in increments of 10 in-lbs. Tighten in pattern shown. See Figure 9.
3. Test for proper chain alignment.
4. Close the motor enclosure.

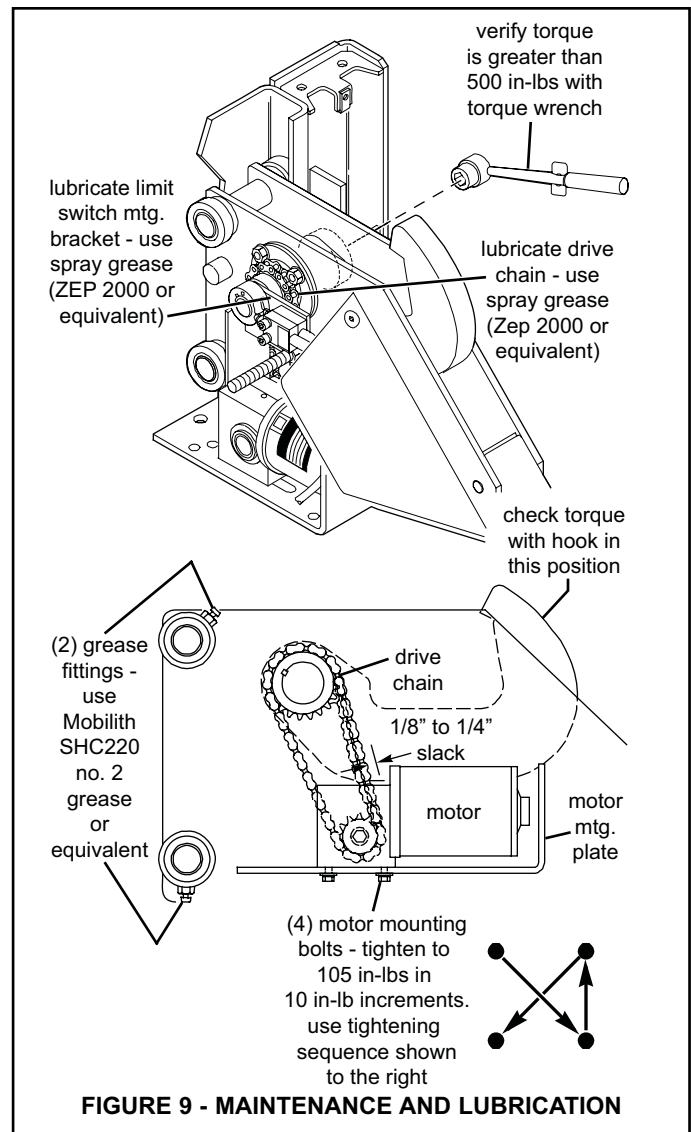

## TROUBLESHOOTING GENERAL DIAGNOSTIC INFORMATION

Problem	Probable Cause	Solution
1. DOK-LOK vehicle restraint hook does not raise and lights do not flash.	<ul style="list-style-type: none"> <li>a. Power source malfunction.</li> <li>b. Power module failure.</li> <li>c. Incorrect wiring.</li> </ul>	<ul style="list-style-type: none"> <li>a. Check power source including building circuit breaker, 1A fuse and circuit breaker on power module.</li> <li>b. Verify the appropriate motor output LED is lit when the LOCK button or UNLOCK button is pressed.</li> <li>c. Verify wiring per Electrical Schematic, Figure 14, page 19.</li> </ul>
2. DOK-LOK vehicle restraint lights are flashing, but hook does not raise/lower, to full extent.	<ul style="list-style-type: none"> <li>a. Chain is loose or broken.</li> <li>b. Tripped circuit breaker.</li> <li>c. Low incoming voltage.</li> <li>d. Power module failure.</li> <li>e. No push button inputs.</li> <li>f. Drive motor defective.</li> <li>g. Incorrect wiring.</li> </ul>	<ul style="list-style-type: none"> <li>a. Adjust or replace as required.</li> <li>b. Reset circuit breaker on power module.</li> <li>c. Verify incoming voltage at L1 and L2 is a minimum of 110V. Do not power off a control transformer from other equipment unless properly sized for load.</li> <li>d. Verify the appropriate LED is lit when the LOCK button or UNLOCK button is pressed.</li> <li>e. Check for defective push button board or ribbon cable.</li> <li>f. Check motor, Figure 10, page 14. Repair or replace as required.</li> <li>g. Verify wiring per Electrical Schematic, Figure 14, page 19.</li> </ul>
3. DOK-LOK vehicle restraint is operational but hook drops causing lights to change and/or horn to sound while trailer is being serviced.	<ul style="list-style-type: none"> <li>a. Drive motor defective.</li> <li>b. Verify clutch torque.</li> </ul>	<ul style="list-style-type: none"> <li>a. Check motor, Figure 10, page 14. Repair or replace as required.</li> <li>b. If clutch torque is less than 500 in lbs replace. Chain is loose or broken. Adjust or replace as required.</li> </ul>
4. DOK-LOK vehicle restraint hook is operational but all lights are out.	<ul style="list-style-type: none"> <li>a. Bulbs burnt out, loose or missing.</li> <li>b. Damaged CPU module.</li> <li>c. Incorrect wiring.</li> </ul>	<ul style="list-style-type: none"> <li>a. Check all bulbs and replace as required.</li> <li>b. If the ISG and OSR LEDs are not flashing while in the LOCKED position or the ISR and OSG LEDs are not flashing while in the UNLOCKED position, replace the CPU module as required.</li> <li>c. Verify wiring per Electrical Schematic, Figure 14, page 19.</li> </ul>
5. DOK-LOK vehicle restraint inside red light and horn are pulsing. Outside red light is flashing. All buttons do not function.	<ul style="list-style-type: none"> <li>a. Controls are in neutral state.</li> </ul>	<ul style="list-style-type: none"> <li>a. Contact your local representative or RITE-HITE.</li> </ul>
6. DOK-LOK vehicle restraint horn does not sound, but lights and hook are operational.	<ul style="list-style-type: none"> <li>a. Horn is defective.</li> <li>b. Damaged CPU module.</li> <li>c. Incorrect wiring.</li> </ul>	<ul style="list-style-type: none"> <li>a. Power horn using 12V DC power. If horn does not sound, replace as required.</li> <li>b. LED labeled HORN should be flashing while in fault state. If not, replace CPU module as required.</li> <li>c. Verify wiring per Electrical Schematic, Figure 14, page 19.</li> </ul>
7. DOK-LOK vehicle restraint inside red light and horn double pulse.	<ul style="list-style-type: none"> <li>a. Limit switch fault. Power must be cycled to clear fault.</li> </ul>	<ul style="list-style-type: none"> <li>a. Check LS1 limit switch if hook is in stored position and LS2 limit switch if hook is in LOCKED position. Replace as required.</li> </ul>
8. DOK-LOK vehicle restraint hook is in stored position with an inside green light.	<ul style="list-style-type: none"> <li>a. Incorrect wiring.</li> </ul>	<ul style="list-style-type: none"> <li>a. Verify wiring of SW1 and SW2 at the control box and outside junction box.</li> </ul>

# TROUBLESHOOTING CONTINUED

Problem	Probable Cause	Solution
9. DOK-LOK vehicle restraint carriage does not return to a full up position.	a. Carriage binding in track. b. Damaged roller track plate. c. Broken or weak springs.	a. Check to see if roller track plate is clean and rollers are clean, free of debris and lubricated. Use only approved grease to lubricate rollers. b. Verify that the roller track plate is straight and not damaged. c. Remove spring cover and replace as required.

## COMPONENT TESTING

### Vehicle Restraint Motor Test Procedure

- BAD O/L:** Little or infinite ohm reading (no needle movement) between pins 43 and 44, 43 and 45. Set multimeter to ohms. Std. readings: Between pins 44 and 45 = 11 ohms; Between pins 44 or 45 and 43 = 5.5 ohms.
- OPEN WINDING:** Infinite ohms (no needle movement) between pins 44 and 45. Check between pins 44 and 43 or 45 and 43 to determine which winding is open.
- MECHANICAL BINDING:** Motor hums. Motor leads show continuity between all windings. Shaft does not move. Reads 6.5 amps at pin 43 on both rotations.

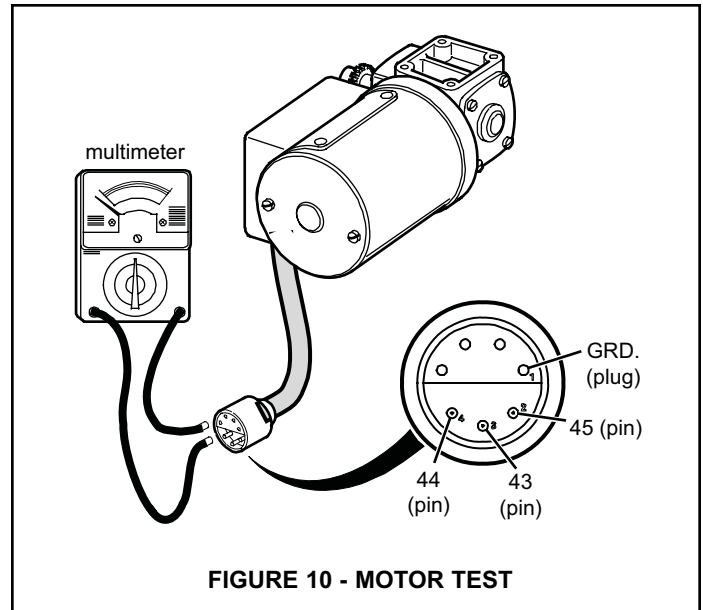

### Limit Switch Test Procedure

- Set multimeter to "RX1" scale for "Continuity Test".
- Attach multimeter leads to pins "B" and "C" of limit switch connector. You should have:
  - plunger released - no meter reading.
  - plunger depressed - a "Full Scale" meter reading.

**NOTE:** The green (ground) wire of the limit switch does not have to be tested. A continuity test lamp may be used instead of a multimeter.

Hook Position	LS1 Position	LS2 Position	Inside Light	Outside Light	Horn
1. Stored	Closed Depressed	Open Released	Red	Green	Off
2. No Hook (Lower Pos.)	Closed Depressed	Closed Depressed	Red	Red	On
3. Hooked (90°)	Open Released	Closed Depressed	Green	Red	Off
4. No Hook (Upper Pos.)	Closed Depressed	Closed Depressed	Red	Red	On

**FIGURE 11 - LIMIT SWITCH AND HOOK POSITION CHART**

# LED STATUS CHART

	LED INPUTS					LED OUTPUTS							OPTIONS		
	SW1	SW2	Lock PB	Unlock PB	PB1, 2, 3	ISR	ISG	OSR	OSG	Horn	M1L	M2L	CR1	CR2	CR3
1) Stored State (Unlocked)	T	F				P	F	F	P	F	F	F	F	*	T
2) Locking.....	T	T	M			T	F	P	F	F	T	F	F	*	T
3) Locked State.....	F	T				F	P	P	F	F	F	F	T	*	T
4) Hook Fault.....	T	T				P	F	P	F	P	F	F	F	*	F
5) RUN Fault.....	?	?				P	F	P	F	P	F	F	F	*	T
6) Horn Silence.....	?	?			M	P	P	P	F	F	F	F	T	*	T
7) Storing (Unlocking).....	T	T		M		T	F	P	F	F	F	T	F	*	T
8) LS Fault.....	F	F				D	F	P	F	D	F	F	F	*	F

SW1 = Limit Switch 1	ISG = Inside Green Light
SW2 = Limit Switch 2	ISR = Inside Red Light
LOCK PB = Lock Push Button	OSG = Outside Green Light
UNLOCK PB = Unlock Push Button	OSR = Outside Red Light
ISR = Inside Red Light	HORN = Alarm Horn
M = Lights when button is pressed	M1L = Motor Up Output
PB1, 2, 3 = Horn silence code push buttons	M2L = Motor Down Output
T = Steady On	CR1 = Green Light Interlock Output
D = Double Pulse	CR2 = Unidox Output
F = Off	CR3 = Security System Output
P = Pulsing/Flashing	Hook Fault = Hook moved but did not sense a Safe Lock/Unlock
* = True when Unidox is enabled	RUN Fault = Hook did not move
? = Varies depending on operation	LS Fault = No Limit Switch Inputs

**FIGURE 12 - LED STATUS CHART**

# HORN OVERRIDE CODE AND DIAGNOSTICS (RHR-1000 MODEL ONLY)

## SETTING HORN OVERRIDE CODE

1. Press and hold DIAGNOSTIC button until horn chirps (approximately three seconds).
2. Enter the factory preset HORN OVERRIDE code: 1223.
3. Enter the new HORN OVERRIDE code. The code can be one to four numbers in length.
4. Once the new code has been entered, press the LOCK button.
5. Controls reset with new HORN OVERRIDE code enabled.

If no buttons are pressed within a five minute period, the controls will automatically retain the previous code. To exit the HORN OVERRIDE code set mode at any time, press the DIAGNOSTIC button.

If code has been forgotten, follow the above procedures and enter a new code.

## DIAGNOSTICS

Diagnostic mode may be entered while the restraint is in any state. To enter diagnostic mode:

1. Press and hold DIAGNOSTIC button until it chirps (approximately 3 seconds).
2. Press the LOCK button.
3. Press the UNLOCK button.
4. The horn chirps and the outside light is flashing red. The controls are in the first step of diagnostic mode. NOTE: The outside red light will remain flashing at all times except Step 5.
5. Start at Step 1 in the Diagnostic Table. If the equipment Outputs do not match the table, use the Troubleshooting section on page 13.

If no buttons are pressed within a five minute period, the controls will automatically exit the diagnostic mode. To exit the diagnostic mode at any time, press the DIAGNOSTIC button.

Operator Action	Outputs	Troubleshooting
Step 1 Press LOCK - Go to Step 2 OSR LED is flashing.	Outside red light is flashing. Check CPU module and 1amp fuse. Inside red light is ON.	Check light bulb and wiring. Step 2 Press UNLOCK - Go to Step 1 Check light bulb and wiring.
Step 2 Press LOCK - Go to Step 3	ISR LED is ON.	Check CPU module and 1amp fuse.
Step 3 Press UNLOCK - Go to Step 2 Press LOCK - Go to Step 4	Inside Green light is ON. ISR LED is ON.	Check light bulb and wiring. Check CPU module and 1amp fuse.
Step 4 Press UNLOCK - Go to Step 3 Press LOCK - Go to Step 5	Inside amber light is ON (if not equipped, go to Step 5). ISA LED is ON.	Check light bulb and wiring. Check CPU module and 1amp fuse.
Step 5 Press UNLOCK - Go to Step 4 Press LOCK - Go to Step 6	Outside red light is ON. OSR LED is ON.	Check light bulb and wiring. Check light bulb and wiring.
Step 6 Press UNLOCK - Go to Step 5 Press LOCK - Go to Step 7	Outside green light is flashing. OSG LED is flashing.	Check light bulb and wiring. Check CPU module and 1amp fuse.
Step 7 Press UNLOCK - Go to Step 6 Press LOCK - Go to Step 8	Horn is ON.  HRN LED is ON.	Check horn and wiring. Test horn applying 12V DC power. Check CPU module and 1amp fuse.
Step 8 Press UNLOCK - Go to Step 7 Press LOCK - Go to Step 9	CR1 LED is ON. (If option card is not installed, go to Step 12).	Check Option module.
Step 9 Press UNLOCK - Go to Step 8 Press LOCK - Go to Step 10	CR2 LED is ON.	Check Option module.
Step 10 Press UNLOCK - Go to Step 9 Press LOCK - Go to Step 11	CR3 LED is ON.	Check Option module.
Step 11 Press UNLOCK - Go to Step 10 Press LOCK - Go to Step 12	Outside red light is flashing. OSR LED is flashing.	See Step 1.

Steps 12 - 16 are used to test the mechanical Inputs and Outputs of the lock (ie. motor, limit switches, etc.). The horn will chirp when the controls enter Steps 12 - 16 to alert the operator to check the hook position. If the hook does not move to the correct position, the horn will double pulse and the inside red light will be ON.

<b>Operator Action</b>	<b>Outputs</b>	<b>Troubleshooting</b>
Step 12 Press LOCK - Go to Step 13.	Hook is in stored position. SW1 LED is ON. SW2 LED is OFF. Inside red light is ON. Outside red light is flashing.	Check motor and verify wiring. Check switch 1 and verify wiring. Check switch 2 and verify wiring. See Step 2. See Step 5.
Step 13 Press LOCK - Go to Step 13.	Hook is in lower fault position. SW1 LED is ON. SW2 LED is ON. Inside red light is ON. Outside red light is flashing.	Check motor and verify wiring. Check switch 1 and verify wiring. Check switch 2 and verify wiring. See Step 2. See Step 5.
Step 14 Press LOCK - Go to Step 15.	Hook is in LOCKED position. SW1 LED is OFF. SW2 LED is ON. Inside red light is ON. Outside red light is flashing.	Check motor and verify wiring. Check switch 1 and verify wiring. Check switch 2 and verify wiring. See Step 2. See Step 5.
Step 15 Press LOCK - Go to Step 16.	Hook is in upper fault position. SW1 LED is ON. SW2 LED is ON. Inside red light is ON. Outside red light is flashing.	Check motor and verify wiring. Check switch 1 and verify wiring. Check switch 2 and verify wiring. See Step 2. See Step 5.
Step 16 Press LOCK - Hook will store and controls exit Diagnostic mode.	Hook is in upper fault position. SW1 LED is ON. SW2 LED is ON. Inside red light is ON. Outside red light is flashing.	Check motor and verify wiring. Check switch 1 and verify wiring. Check switch 2 and verify wiring. See Step 2. See Step 5.

# CONTROL HARNESS

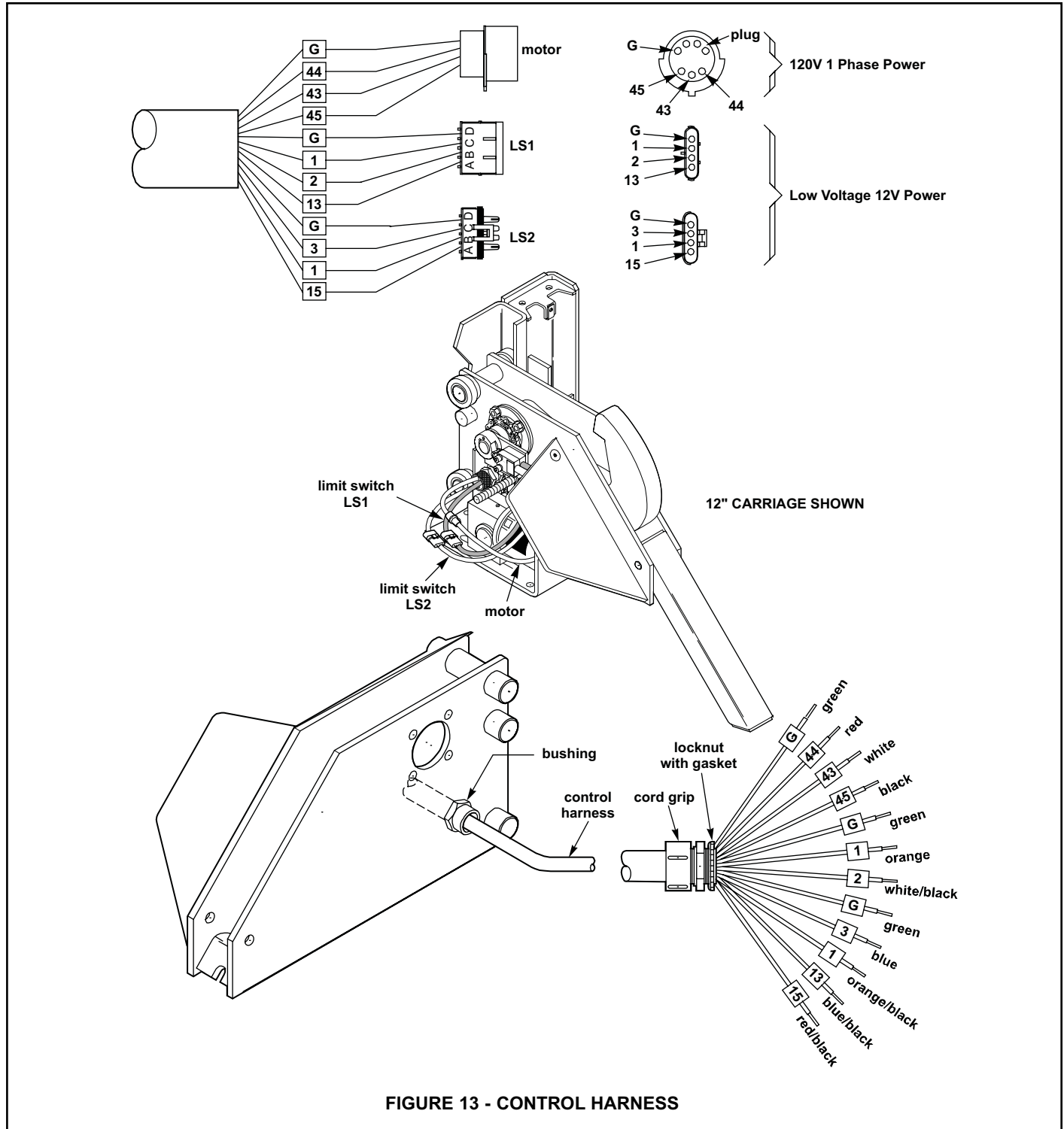

FIGURE 13 - CONTROL HARNESS

# ELECTRICAL SCHEMATIC

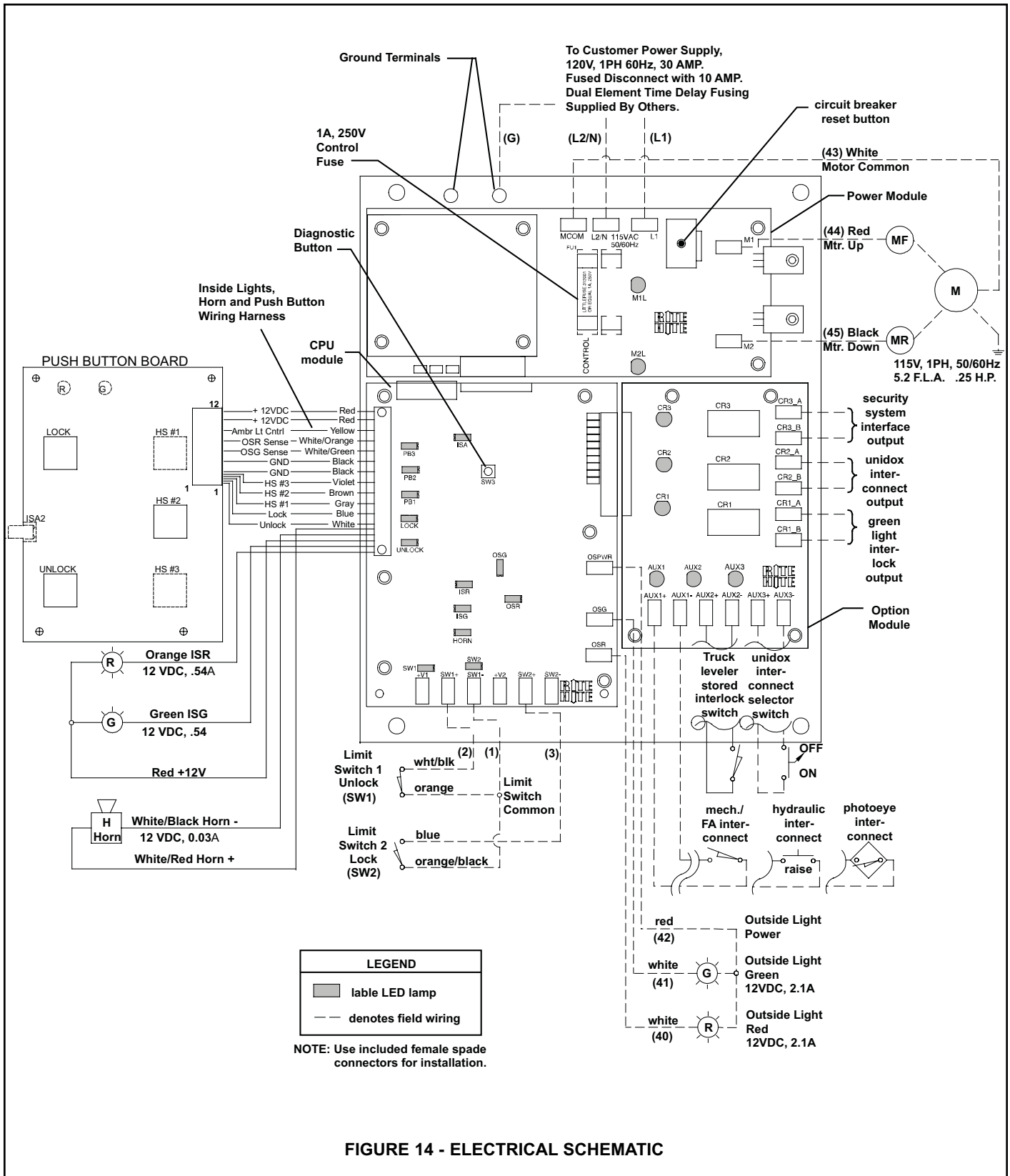

FIGURE 14 - ELECTRICAL SCHEMATIC

## OUTSIDE LIGHT BOX WIRING

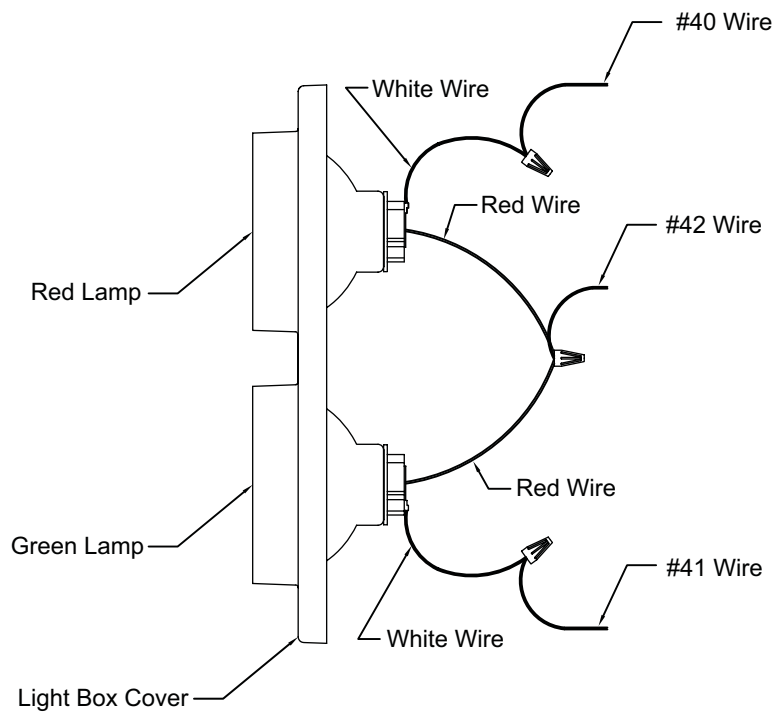

FIGURE 15 - OUTSIDE LIGHT BOX WIRING

# NOTES



## 9" CARRIAGE REPLACEMENT PARTS LIST

Item	Qty	Description	Part Number
1	1	Roller track	01955
2	4	Cage nut	56540
3	1	Spring cover, left hand	54849
4	4	Extension spring	52129
5	1	Spring cover, right-hand	01954
6	4	Mounting bolt (5/16" – 18NC x 1" long) flat head socket	18210
7	15	Concrete anchor 5/8" dia. x 4" long (Rawl #6942 or equivalent)	53150
8	2	Socket head screw (1/4" x 20NC x 1-1/2" long)	51636
9	2	Hi-collar lock washer (1/4")	51802
10	1	LS2 limit switch – includes item 33	18212
11	1	LS1 limit switch – includes item 33	18211
12	1	Spiral retaining ring (1-3/16" ID)	56526
13	1	Cam	19123
14	2	Sprocket and cam key (1/4" x 1/4" x 7/8" long)	54864
15	2	Set screw (5/16" – 18NC x 5/16" long)	56525
16	1	Cam decal	18213
17	1	Limit switch mounting plate	19124
18	5	Serrated flange whiz nut (7/16" – 14NC)	51549
19	1	Hook drive sprocket with set screw (#35 – 27 tooth)	56177
20	1	Chain	19125
21	8	Serrated flange whiz nut (3/8" – 16NC)	51564
22	2	Bearing	06085
23	4	Carriage roller	15782
24	1	Carriage	106700
25	6	Carriage bolt (3/8" – 16NC x 1" long)	58022
26	1	Conduit nipple	18204
27	1	Locknut	55791
28	1	Hook shaft	54987
29	1	Conduit bushing	57978
30	1	Harness cord grip (3/4" x 11/16" – 13/16")	66082
31	1	Harness locknut with gasket	55877
32	1	Motor assembly – includes item 33	106708
33	1	Wire tie (motor and limit switch)	18548
34	1	Lower spring bar mounting plate	01957
35	1	Control harness (item 27 is locknut for harness)	18205
36	4	Bolt (5/16" – 18NC x 5/8" long)	58069
37	1	Patent number tag	18391
38	1	Carriage logo decal, left side	19031
39	1	Carriage logo decal, right side	19030
40	1	Motor cover assembly – includes item 41	19213
41	1	NO STEP WARNING decal	54126
42	1	Slope ext. assm. – items 43 [Qty. 2], 47 [Qty. 2], 49, 50 [Qty. 4]; and 51	19214
43	2	Slope ext. pivot pin (1" x 3-1/2")	105495
44	2	Grease Fitting	51169
45	2	Machinery bushing	51745
46	1	Hook	18208
47	2	Cotter Pin .16" x 1.5"	105865
48	1	Hook key (1/4" x 1/4" x 1-1/4" long)	54818
49	1	Slope extension, lower	18960
50	4	Machinery bushing (.06 thick x 1.015 I.D.)	19128
51	1	Slope extension, upper	18961
52	2	Bolt hook stop	68207
53	1	Ny-Lock nut (7/16" – 14NC)	51543
54	1	Wire tie (limit switch)	55592

# STANDARD RHR-600 PARTS - 12" CARRIAGE & TRACK

## OPTIONAL RHR-1000 PARTS - 12" CARRIAGE

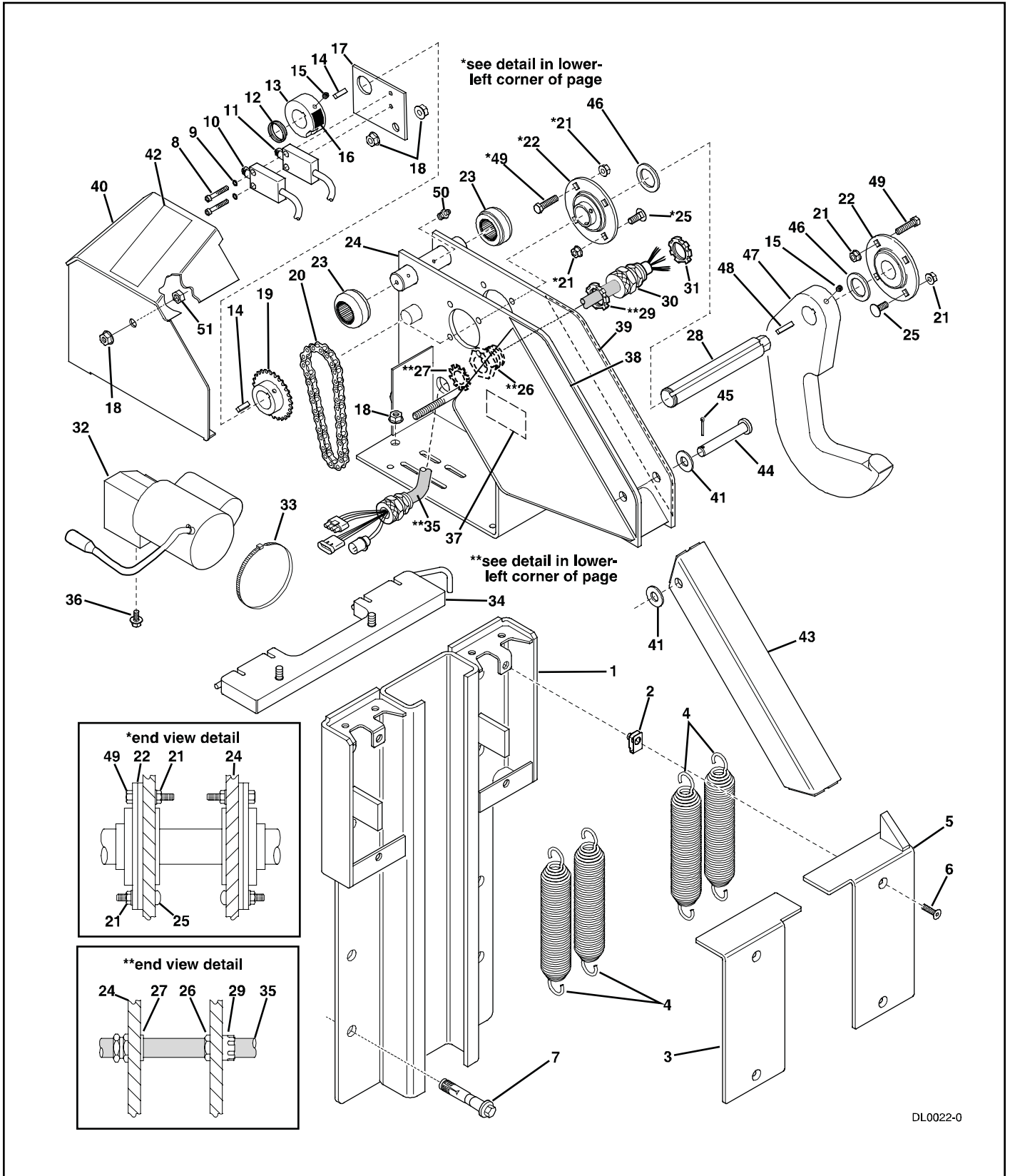

## 12" CARRIAGE REPLACEMENT PARTS LIST

Item	Qty	Description	Part Number
1	1	Roller track	1955
2	4	Cage nut	56540
3	1	Spring cover, left-hand	54849
4	4	Extension spring	52129
5	1	Spring cover, right-hand	1954
6	4	Mounting bolt (5/16" – 18NC x 1" long) flat head socket	18210
7	15	Concrete anchor 5/8" dia. x 4" long (Rawl #6942 or equivalent)	53150
8	2	Socket head screw (1/4" x 20NC x 1-1/2" long)	51636
9	2	Hi-collar lock washer (1/4")	51802
10	1	LS2 limit switch – includes item 33	18212
11	1	LS1 limit switch – includes item 33	18211
12	1	Spiral retaining ring (1-3/16" I.D.)	56526
13	1	Cam	53432
14	2	Sprocket and cam key (1/4" x 1/4" x 7/8" long)	54864
15	2	Set screw (5/16" – 18NC x 5/16" long)	56525
16	1	Cam decal	18213
17	1	Limit switch mounting plate	18285
18	5	Serrated flange whiz nut (7/16" – 14NC)	51549
19	1	Hook drive sprocket with set screw (#35 – 27 tooth)	56177
20	1	Chain	56175
21	8	Serrated flange whiz nut (3/8" – 16NC)	51564
22	2	Bearing	6085
23	4	Carriage roller	15782
24	1	Carriage	106699
25	6	Carriage bolt (3/8" – 16NC x 1" long)	58022
26	1	Conduit nipple	18204
27	1	Locknut	55791
28	1	Hook shaft	54987
29	1	Conduit bushing	57978
30	1	Harness cord grip (3/4" x 11/16" – 13/16")	66082
31	1	Harness locknut with gasket	55877
32	1	Motor assembly – includes Item 33	106708
33	1	Wire tie (motor and limit switch)	18548
34	1	Lower spring bar mounting plate	1957
35	1	Control harness (item 27 is locknut for harness)	18205
36	4	Bolt (5/16" – 18NC x 5/8" long)	58069
37	1	Patent number tag	18391
38	1	Carriage logo decal, left side	59009
39	1	Carriage logo decal, right side	59008
40	1	Motor cover assembly – includes item 42	1995
41	2	Washer (5/8" I.D.)	51711
42	1	NO STEP WARNING decal	54126
43	2	Slope extension	1883
44	2	Slope extension pivot pin	105494
45	1	Cotter Pin .16" x 1"	105864
46	2	Machinery bushing	51745
47	1	Hook	18208
48	1	Hook key (1/4" x 1/4" x 1-1/4" long)	54818
49	2	Bolt hook stop	68207
50	2	Grease fitting	51169
51	1	Nylock Nut (7/16" x 14NC)	51543

# ELECTRICAL PARTS

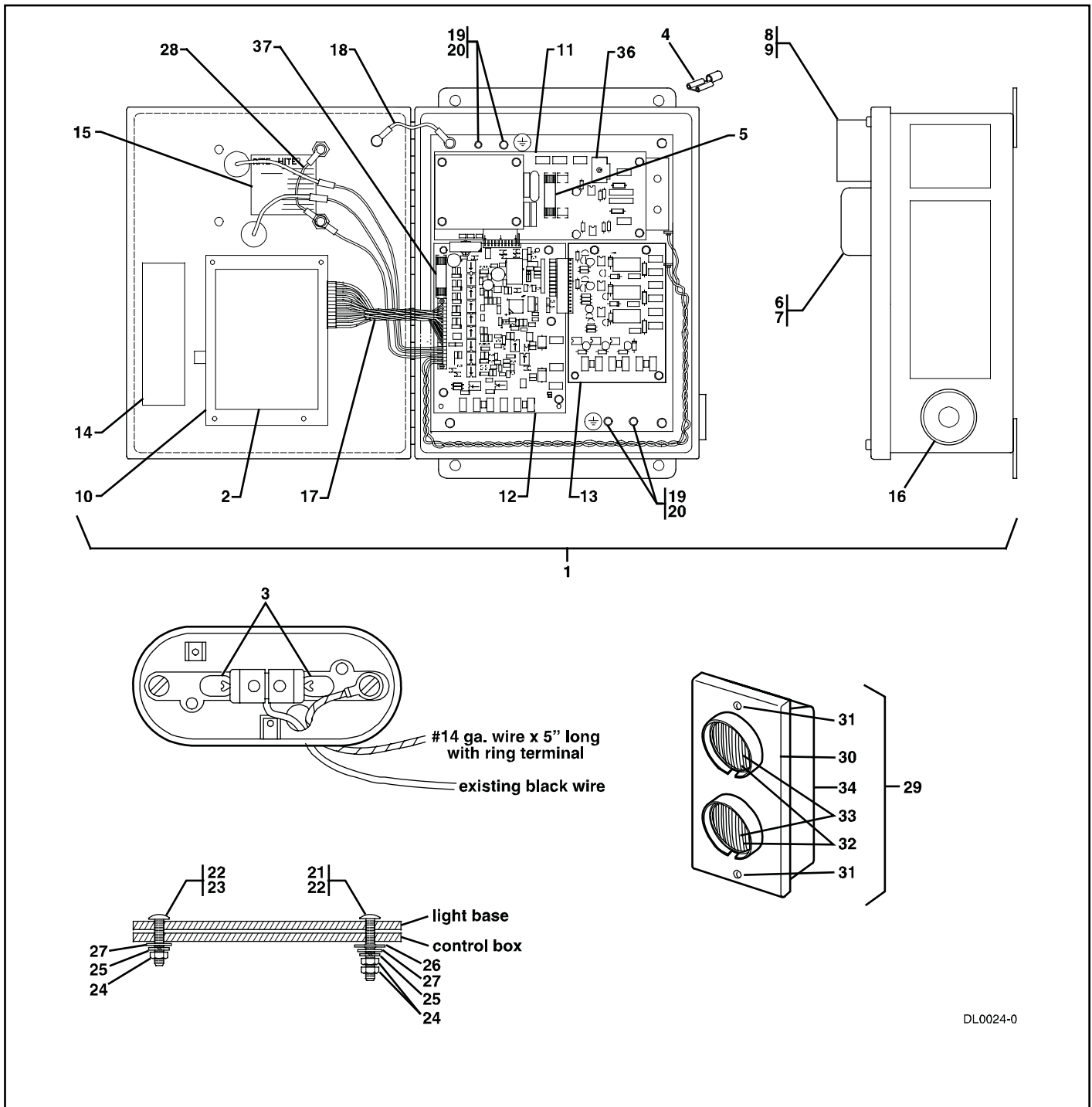

## ELECTRICAL REPLACEMENT PARTS LIST

Item	Qty	Description	Part Number
1	1	Control box assembly, complete (Consult RITE-HITE for specific part)	103.xxx
2	1	Electrical schematic decal (Consult RITE-HITE for specific part)	108.xxx
3	2	Inside red LED bulbs	116363
	2	Inside green LED bulbs	116364
	4	Light bulb (#194 - Incandescent)	55768
4	16	Insulated female terminal 1/4", 14-16 awg	55726
5	1	Fuse, 1amp 250volt fast blo	107571
6	1	Inside signal light, green assembly	55742
7	1	Inside signal light, green lens	55812
8	1	Inside signal light, red assembly	57803
9	1	Inside signal light, red lens	57840
10	1	Push button module, 3 button - includes mounting hardware - RHR-600	105433
10	1	Push button module, 5 button – includes mounting hardware - RHR-1000	105436
11	1	Power module with circuit breaker – includes subplate & mounting hardware	105438
12	1	CPU module – includes mounting hardware (P/N RHR6/1000)	109165
13	1	Options module, not included in STANDARD control box assembly	105448
14	1	Program configuration decal (Consult RITE-HITE for specific part)	107.xxx
15	1	Full Load Amp and Voltage Decal (Consult RITE-HITE for specific part)	110.xxx
16	1	Horn, 12VDC	57383
17	1	Wiring harness	105460
18	1	Grounding harness	105456
19	4	Screw, panhead (#10-32 x .250)	105455
20	4	Lock washer, internal tooth #10	51828
21	1	Screw, round head #8-32 x 1.00 (red light only)	51656
22	2	Screw, round head #8-32 x .75	51672
23	1	Screw, round head #8-32 x .50 (green light only)	51645
24	6	Nut, hex (#8-32)	51538
25	4	Lock washer, external tooth #8	51760
26	2	Washer, nylon 0.26 ID x 0.75 OD x 0.10 thk	53164
27	4	Bushing, nylon	53147
28	1	Common wire, light assembly	108179
29	1	Outside light box LED, complete	115798
	1	Outside light box, complete (Incandescent)	18280
30	1	Outside light box cover LED, with lamps & lenses	128458
	1	Outside light box cover, with lamps & lenses (Incandescent)	115298
31	2	Screw, round head #6-32 x 3/4" Long	18364
32	1	Outside red LED bulb	128448
	1	Outside green LED bulb	128449
	2	Light bulb (GE #1156 - Incandescent)	57187
33	2	Lamp socket assembly	116894
34	1	Outside light box, NEMA 3R, (without cover)	18277
35	1	URC Circuit Board Cover (Not Shown)	108073
36	1	Circuit Breaker	107576
37	1	Fuse, 4 Amp	119018

## MISC. PARTS

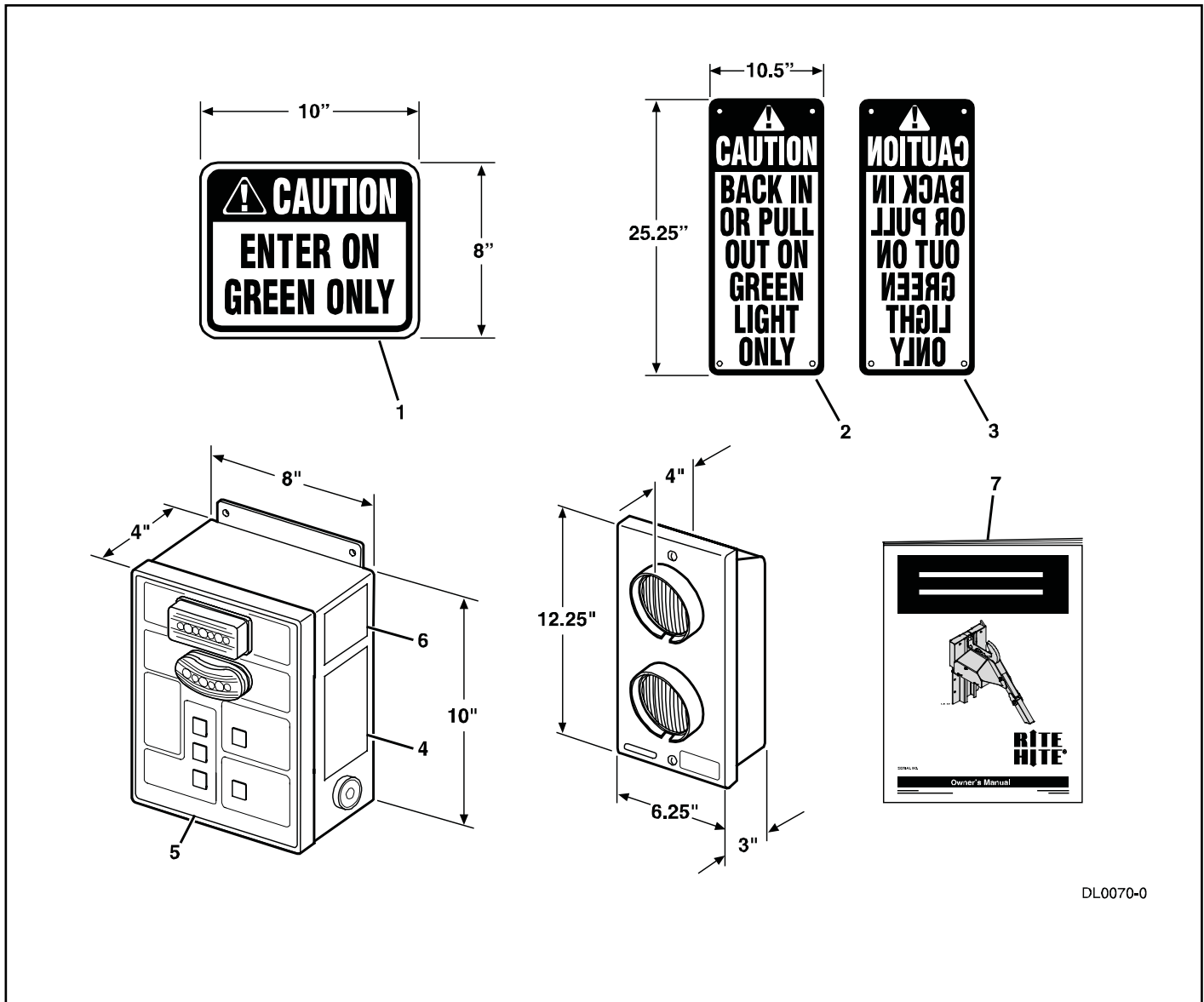

DL0070-0

### MISCELLANEOUS REPLACEMENT PARTS LIST

Item	Qty	Description	Part Number
1	1	Interior Warning sign	56095
2	1	Narrow sign (normal letters)	56112
3	1	Narrow sign (reverse letters)	56113
4	1	RHR warning decal	105428
5	1	Cover decal - 5 button - RHR-1000	105424
5	1	Cover decal - 3 button - RHR-600	105423
6	1	Lockout/tagout warning decal	105430
7	1	RHR-1000/600 Owner's manual (Publication No. 1208)	Pub. No. 1208

# NOTES

# NOTES

# NOTES

## **RITE-HITE® STANDARD WARRANTY**

RITE-HITE® warrants that its products will be free from defects in design, materials, and workmanship for a period of 365 days from the date of shipment. All claims for breach of this warranty must be made within 30 days after the defect is or can, with reasonable care, be detected and in no event no more than 30 days after the warranty has expired. In order to be entitled to the benefits of this warranty, the products must have been properly installed, maintained, and operated within their rated capacities and/or specified design parameters, and not otherwise abused. Periodic lubrication and adjustment is the sole responsibility of the owner. This warranty is RITE-HITE's® exclusive warranty. RITE-HITE® EXPRESSLY DISCLAIMS ALL IMPLIED WARRANTIES, INCLUDING THE IMPLIED WARRANTIES OF MERCHANTABILITY AND FITNESS. Non-standard warranties, if any, must be specified by RITE-HITE® in writing.

In the event of any defects covered by this warranty, RITE-HITE® will remedy such defects by repairing or replacing any defective equipment or parts, bearing all the costs for parts, labor, and transportation. This shall be the exclusive remedy for all claims whether based on contract, negligence, or strict liability.

## **LIMITATION OF LIABILITY**

RITE-HITE® SHALL NOT IN ANY EVENT BE LIABLE FOR ANY LOSS OF USE OF ANY EQUIPMENT OR INCIDENTAL OR CONSEQUENTIAL DAMAGES OF ANY KIND, WHETHER FOR BREACH OF WARRANTY, NEGLIGENCE, OR STRICT LIABILITY.



### **Global Sales & Service Office:**

**RITE-HITE®  
8900 N. Arbon Drive  
P.O. Box 245020  
Milwaukee, Wisconsin 53224**

**Phone: 414-355-2600  
1-800-456-0600  
[www.ritehite.com](http://www.ritehite.com)**

**Representatives in all Major Cities**